

USER MANUAL

Z-DAQ-PID

Universal input with pid controller



SENECA s.r.l.

Via Austria 26, PADOVA – ITALY

Tel. +39.049.8705355 – 8705359 Fax. +39.049.8706287

Web site: www.seneca.it

Technical assistance: supporto@seneca.it (IT), support@seneca.it (Other)

Commercial reference: commerciale@seneca.it (IT), sales@seneca.it (Other)

This document is property of SENECA srl. Duplication and reproduction are forbidden, if not authorized. Contents of the present documentation refers to products and technologies described in it. All technical data contained in the document may be modified without prior notice Content of this documentation is subject to periodical revision.

To use the product safely and effectively, read carefully the following instructions before use. The product must be used only for the use for which it was designed and built. Any other use must be considered with full responsibility of the user. The installation, programming and set-up is allowed only for authorized operators; these ones must be people physically and intellectually suitable. Set up must be performed only after a correct installation and the user must perform every operation described in the installation manual carefully. Seneca is not considered liable of failure, breakdown, accident caused for ignorance or failure to apply the indicated requirements. Seneca is not considered liable of any unauthorized changes. Seneca reserves the right to modify the device, for any commercial or construction requirements, without the obligation to promptly update the reference manuals.

No liability for the contents of this documents can be accepted. Use the concepts, examples and other content at your own risk. There may be errors and inaccuracies in this document, that may of course be damaging to your system. Proceed with caution, and although this is highly unlikely, the author(s) do not take any responsibility for that. Technical features subject to change without notice.

MI002643-E

Seneca Z-PC Line module: Z-DAQ-PID

The Z-DAQ-PID module acquires one universal input signal (voltage, current, potentiometer, thermo-couple, thermo-resistance, m-voltmeter) and converts it to an analog format (with PID regulation).

General characteristics

- Three operating mode: conversion with PID regulator, conversion without PID regulator, manual (constant output configurated through ModBUS register)
- Two output types: analog or ON/OFF (time of high-state digital signal is directly proportional to the analog signal)
- Universal input: voltage, current, potentiometer, thermocouple (TC), RTD (Resistance Temperature Detector) , m-voltmeter
- Analog Output: voltage type, active current type, passive current type
- Slew-rate, burn-out, output limiters setup
- Modbus address and baudrate configurable by Dip-Switches

1. Features

INPUT	
Number	1
Resolution	15 bits
Sampling time	Configurable between: 5 ms ("Fast", no rejection), 16.66 ms (rejection to 60 Hz) or 20 ms (rejection to 50 Hz)
Filter	Configurable between: 0 (no filter is applied), from 1 (min) to 19 (max)
Response time	Sampling time + 6 ms
Voltage-type IN	Scale range is configurable: from 0 V to 10 V. Input impedance:>5MΩ
Current-type IN (mA-passive module/mA-active module)	Scale range is configurable: from 0 mA to 20 mA. Internal shunt: 50Ω.It's possible to power the sensor by: itself (mA-passive module) or module (mA-active module) using #7 screw terminal (max 25 mA to max 17 V, short-circuited protected)

USER MANUAL – Z-DAQ-PID

Potentiometer-type IN	Scale range is configurable: from 1 k Ω to 100 k Ω (with parallel resistor R=330 Ω to connect externally). Excitation current:1 mA. Input impedance:>5M Ω
Thermocouple-type IN	For TC type: J, K, R, S, T, B, E, N. Input impedance:>5 M Ω . Automatic detection if a TC interruption occurs
RTD-type IN	For RTD type: PT100, PT500, PT1000, NI100. Resistance measure (for 2,3 or 4-wires connection) and wire-resistance measure (for 3,4-wires connection). Excitation current: 1.1 mA (PT100) and 0.11 Ma (PT1000, PT500). Automatic detection if a wire or RTD interruption occurs
Millivoltmeter-type IN	Scale range is configurable: from -10 mV to 80 mV. Input impedance:>5 M Ω

Errors related to max measuring range	Accuracy	Thermal stability	Linearity error	EMI
Voltage or current-type input	0.1%	0.01%/°K	0.05%	<1% (2)
TC-type input: J,K,E,T,N	0.1%	0.01%/°K	0.2°C	<1% (2)
TC-type input:R,S	0.1%	0.01%/°K	0.5°C	<1% (2)
TC-type input:B (3)	0.1%	0.01%/°K	1.5°C	<1% (2)
Cold junction compensation (for TC-type input)	2°C between 0-50°C	/	/	/
POT-type IN	0.1%	0.01%/°K	0.1%	<1%
RTD-type IN (4)	0.1%	0.01%/°K	0.02% (if t>0°C) 0.05% (if t<0°C)	<1% (5)

(1) For the input scale ranges, see “Connections”

(2) Influence of wire resistance: 0.1 μ V/ Ω

(3) Output zero if t<400°C

(4) For RTD type: PT100, PT500, PT1000, NI100. All the errors have to be calculated with reference to resistive value

(5) Influence of wires resistance: 0.005%/ Ω , max20 Ω

OUTPUT	
Number	1
Resolution	14 bit
Signal-amplitude limiting	The output signal can be amplitude-limited by an “output limiter”
Voltage-type OUT	Configurable between: 0-5 V, 0-10 V (with minimum load resistance: 1 k Ω). Saturation value: 10.5 V
Current-type OUT (active or passive)	Configurable between: 0-20 mA, 4-20 mA (with maximum load resistance: 600 Ω). Saturation value: 21 mA. “Active current” =the output: already powered on, needs to be connected to the passive module; “passive current” =the output: powered off, needs to be connected to the active module

Errors related to max measuring range	Errors related to max measuring range	Accuracy	Thermal stability	Linearity error
Voltage-type OUT	0.1%	0.01%/°K	0.01%	<1%
Voltage-type OUT (active or passive)	0.1%	0.01%/°K	0.01%	<1%

CONNECTIONS	
RS485 interface	IDC10 connector
RS232 interface	Micro USB connector (front-side panel)
1500 Vac ISOLATIONS	
	Between: power supply, ModBUS RS485, analog input, analog output

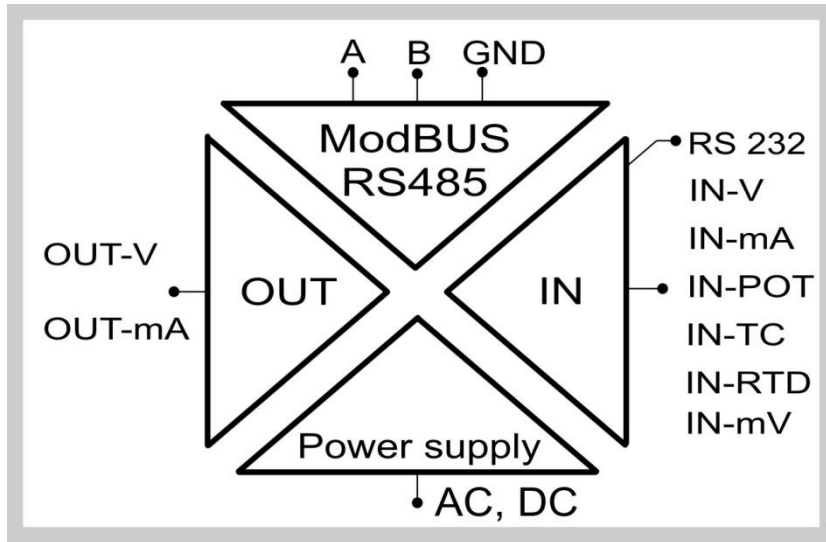

POWER SUPPLY	
Supply voltage	10 – 40 Vdc or 19 – 28 Vac (50Hz - 60Hz)
Power consumption	Min: 0.5 W; Max: 2 W

The power supply transformer necessary to supply the module must comply with EN60742 (Isolated transformers and safety transformers requirements).

2. Connections

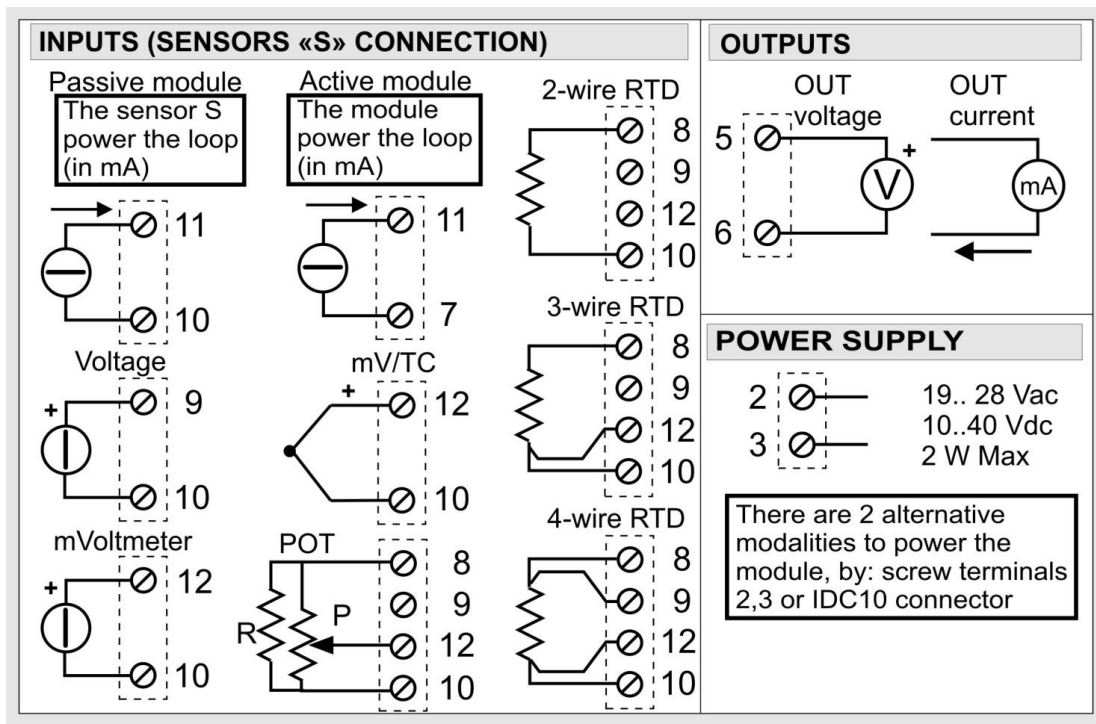

 For potentiometer input connection: you must add externally a $R=330\ \Omega$, $P=1\ k\Omega$ - $100\ k\Omega$.

3. Temperature Input Ranges

The input ranges are shown in the following tables for Thermocouple:

TC-type	Scale range	TC-type	Scale range
J	-210°C..1200°C	S	-50°C..1768°C
K	-200°C..1372°C	R	-50°C..1768°C
E	-200°C..1000°C	B	250°C..1820°C
N	-210°C..1300°C	T	-200°C..400°C

The input scale range values, for RTD are shown in the following table.

RTD-type	Scale range	RTD-type	Scale range
PT100	-210°C..650°C	PT1000	-200°C..210°C

PT500	-200°C..750°C	NI100	-60°C..250°C
-------	---------------	-------	--------------

4. Operation Modes

There are six possible functioning modalities for the Z-DAQ-PID, with reference to the following figure:

- conversion with PID, analog output
- conversion with PID, ON/OFF output
- conversion without PID, analog output
- conversion without PID, ON/OFF output
- manual (constant output), analog output
- manual (constant output), ON/OFF output

With reference to the following figure, the lowest part shows the Z-DAQ-PID setting procedure in three steps: input setting, operating modality setting, output setting.

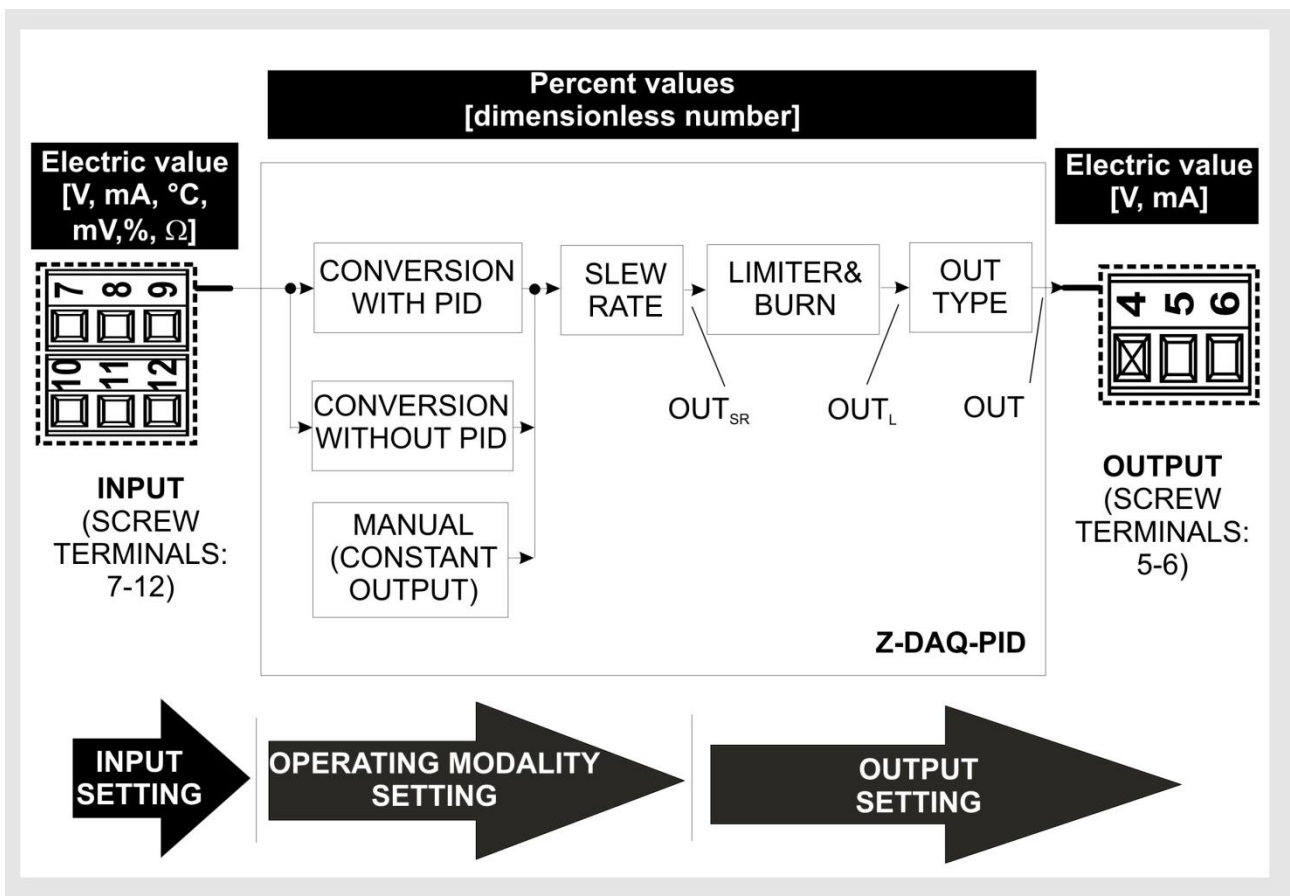

In particular, there are three operating modes, each of them allows to supply a ON/OFF output or an analog output:

USER MANUAL – Z-DAQ-PID

Operating modality	Description
Conversion with PID	The analog output is a function of the analog input processed by the PID transfer function. Moreover, analog output is directly proportional to the analog input
Conversion without PID	The analog output is directly proportional to the analog input
Manual (constant output without PID)	The analog output is input-independent. Anyhow, the input is acquired and can be found in the RS485 registers (only reading)

Slew rate allows to limit the slope of the signal (see reg.40031 and 40032) and burn-out allows to overwrite the OUT-Fault value (reg.40020, 40021) to the reg.40105, 40106 (burn-out overwriting is available only for analog output).

Operating modality is configurable by software or by FunctionMod register (40007.[15:8]), with reference to the “RS485 registers table”.

There are two output type of Z-DAQ-PID, regardless of operating modality:

Out type	Description
Analog	OUT is an analog signal
ON-OFF (see the following figures)	OUT is a ON/OFF signal. High state output is OUT-ES, low state output is OUT-SS

If out type is “ON/OFF”, the Z-DAQ-PID module allows to have a ON/OFF output with activation time t_{ON} (time corresponding to the high-state output) directly proportional to OUT_L .

To understand the ON/OFF out type functioning, see the following figure.

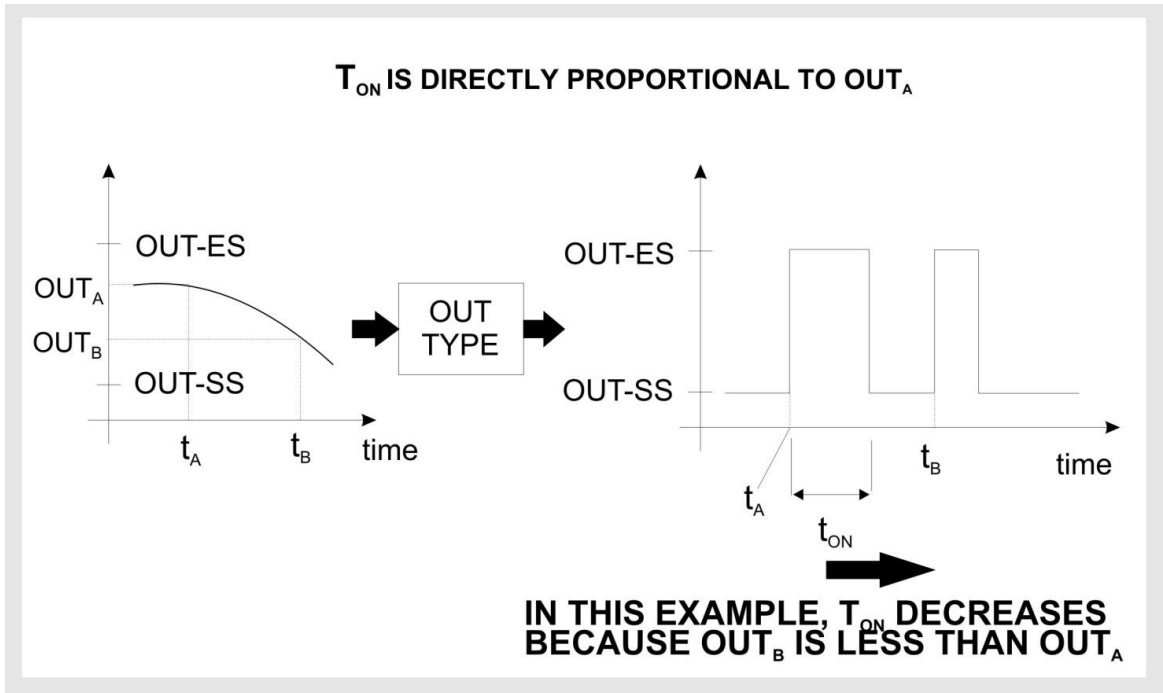

It is possible to limit upper time of high-state ON/OFF output (reg.40029) and to limit lower time of low-state ON/OFF output (reg.40030). The cycle time is reg.40028 (constant frequency of ON/OFF output=1/cycle time).

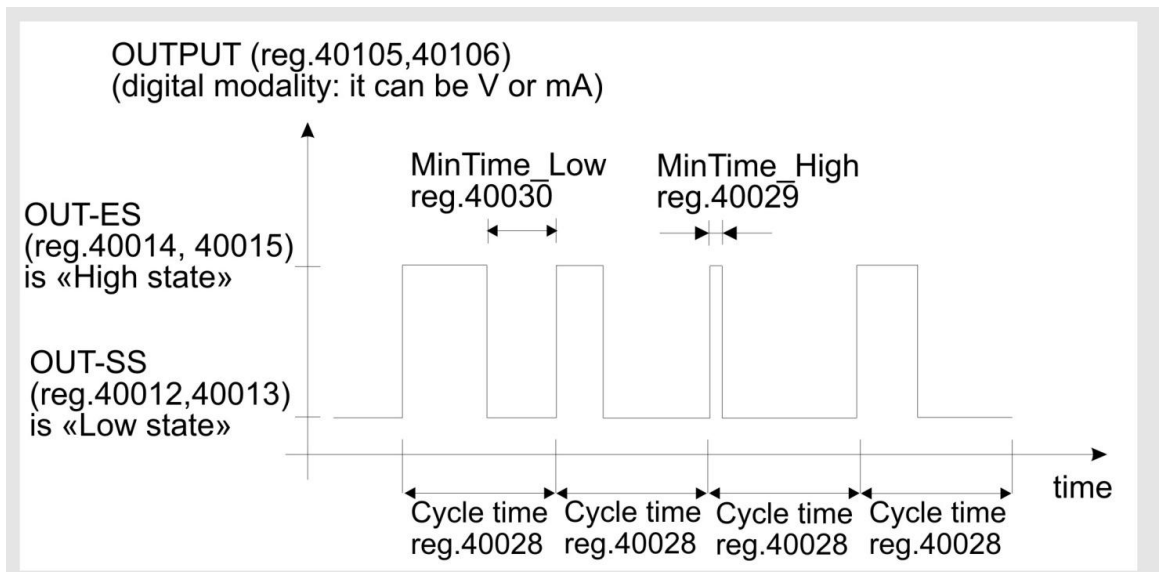

CONVERSION WITH PID

In “Conversion with PID” operating mode, the output (analog or ON/OFF) is a function of the analog input processed by the PID transfer function. Moreover, output is directly proportional to the analog input.

PID regulation allows to incline input signal PV (process value) to SP (set point value) with particular properties (rise time, overshoot, steady-state error, settling time, etc...). In the following figure is shown the Z-DAQ-PID module used as PID.

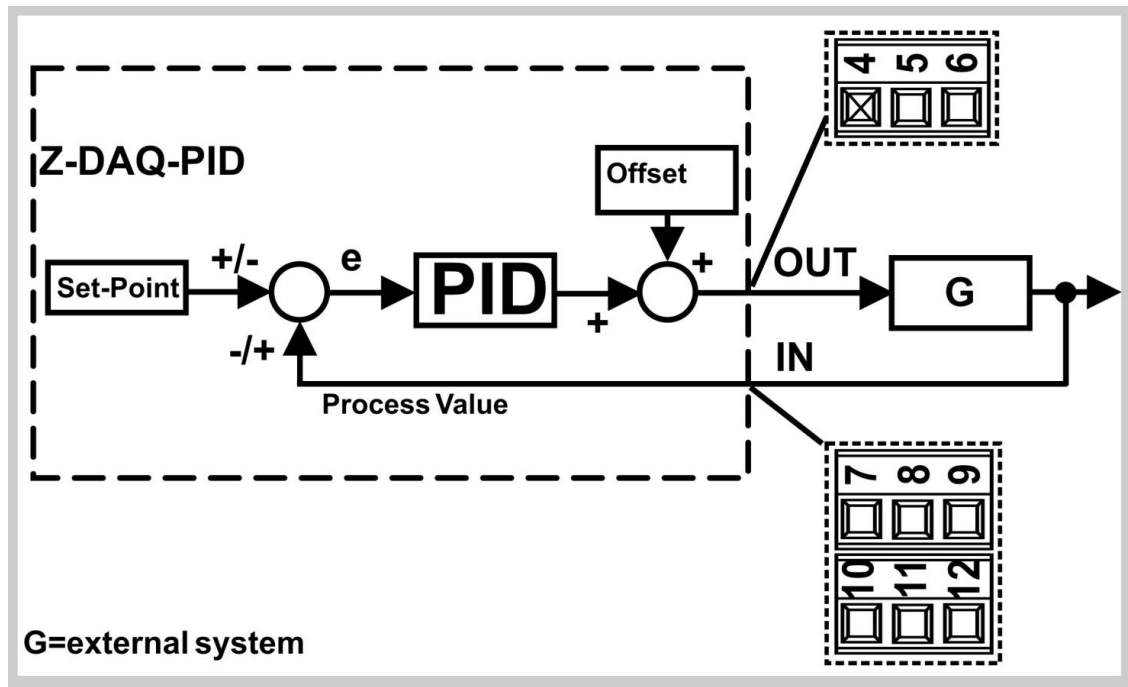

In particular, “e” means the difference between set-point and process-value:

Signal error $e = (\text{process value} - \text{set point})$ means PID regulation direct-type (for example: used for cooling)

Signal error $e = (\text{set point} - \text{process value})$ means PID regulation reverse-type (for example: used for heating)

The PID regulation is described by the following parameters:

Term	Parameter	Meaning	Register
Proportional	BP	Proportional band	40025
Integral	Ti	Integral time	40026
Derivative	Td	Derivative time	40027

where T_{sample} means the PID sampling time (it is equal to 100ms).

If BP decreases

Proportional action strengths	Proportional action weaknesses
Rise time decreases	Ringing and overshoot increases
Steady-state error decreases	

If Ti decreases

Integral action strengths	Integral action weaknesses
Steady-state error is equal to zero (if input is a constant value)	Rise time increases
	Settling time increases

If Td increases

Derivative action strengths	Derivative action weaknesses
Settling time decreases	Noise is amplified

5. Setup

Input setting

To set Z-DAQ-PID input characteristics, configure the following registers:

Description of register	Option/Meaning	Address
Input type	V, mA, %, °C, Ω, mV (see RS485 register table)	40003
Cold-junction compensation (if TC-type input)	0=deactivated 1=activated	40005.8
Input start scale	Value in [V, mA, %, °C, Ω, mV]	40008 (MSW) 40009 (LSW)
Input end scale	Value in [V, mA, %, °C, Ω, mV]	40010 (MSW) 40011 (LSW)

USER MANUAL – Z-DAQ-PID

Filter applied to input signal	0=deactivated 1-19=filtering values	40005.[7:0]
Rejection	0b00=50Hz rejection 0b01=60Hz rejection 0b10=Fast (no rejection)	40006.[9:8]

Operating mode setting

To set Z-DAQ-PID functioning modality characteristics, configure the following registers:

Description of register	Option/Meaning	Address
Functioning modality	0=Conversion with PID, analog output 1=Conversion without PID, analog output 2=Conversion with PID, ON/OFF output 3=Conversion without PID, ON/OFF output 4=Manual, analog output 5=Manual, ON/OFF output	40007.[15:8]

Cycle time	Time in [sec/10] (if output modality=ON/OFF)	40028
Minimum time of high-state ON/OFF output	Time in [sec/10] (if output modality=ON/OFF)	40029
Minimum time of low-state ON/OFF output	Time in [sec/10] (if output modality=ON/OFF)	40030

SlewRate enabling	0=deactivated 1=activated	40031
SlewRate	Value in [%/sec]	40032

PID regulation sign	1=direct-type (example: cooling) 0=reverse-type (example: heating)	40007.[7:0]
---------------------	---	-------------

USER MANUAL – Z-DAQ-PID

	(if operating modality=conversion with PID)	
Set point (it corresponds to the process-value desired)	Value in [%], with reference to the input scale range (if operating modality=conversion with PID)	40022 (MSW) 40023 (LSW)
Proportional band (BP)	Value in [%], with reference to the input scale range (if operating modality=conversion with PID)	40025
Integral time	Time in [sec/10] (if operating modality=conversion with PID)	40026
Derivative time	Time in [sec/10] (if operating modality=conversion with PID)	40027
Offset	Value in [%/100], with reference to the output scale range (if operating modality=conversion with PID)	40024

Output setting

To set Z-DAQ-PID output characteristics, configure the following registers:

Description of register	Option/Meaning	Address
Output type	0=current 1=voltage	40004.8
Output current type	0=active current (the module supplies the loop) 1=passive current (the sensor supplies the loop) (if output type is current)	40004.12
Output start scale	Value in [V, mA]	40012 (MSW) 40013 (LSW)

Output end scale	Value in [V, mA]	40014 (MSW) 40015 (LSW)
------------------	------------------	----------------------------

Output limiter enabling	0=deactivated 1=activated	40004.0
Limit inferior of the output limiter	Value in [%], with reference to the output scale range	40018 (MSW) 40019 (LSW)
Limit superior of the output limiter	Value in [%], with reference to the output scale range	40016 (MSW) 40017 (LSW)

6. Dip-switches table

 In the following tables: box without circle means Dip-Switch=0 (OFF state); box with circle means Dip-Switch=1 (ON state).

BAUD-RATE (Dip-Switches: SW1)						
1	2	Meaning				
		Baud-rate=9600 Baud				
	●	Baud-rate=19200 Baud				
●		Baud-rate=38400 Baud				
●	●	Baud-rate=57600 Baud				
ADDRESS (Dip-Switches: SW1)						
3	4	5	6	7	8	Meaning
						Address and Baud-Rate are acquired from memory(EEPROM)
					●	Address=1
				●		Address=2
				●	●	Address=3
			●			Address=4
X	X	X	X	X	X

•	•	•	•	•	•	Address=63
RS485 TERMINATOR (Dip-Switches: SW2)						
1	2	Meaning				
		RS485 terminator disabled				
	•	RS485 terminator enabled				

7. Modbus RTU protocol

All registers are “Holding register” (Read Modbus function 3) with the convention that the first register is the 40001 address.

The following Modbus functions are supported:

Read Single Modbus Register (function 3)

Write Single Modbus Register (function 6)

Write Multiple Modbus Registers (function 16)

All values in 32bits are stored into 2 consecutive registers, for example:

If a floating point 32 bits is stored into registers 40135 and 40136, the Most significant word is the register 40135, the less significant word is the 40136.

So the 32bits value is obtained by the following relation:

$$VRMS A = Reg40136 + (Reg40135 \times 2^{16}) = Reg40136 + (Reg40135 \times 65536)$$

Abbreviation used

In the following table this abbreviations are used:

“MS” = Most significant
“LS” = Less significant

“MSB” = Most significant Byte
“LSB” = Less significant Byte
“MSW” = Most significant Word (16 bits)
“LSW” = Less significant Word (16 bits)
“R” = Read only register
“RW” = Read and write register
“R/W*” = Read and write register (flash store with command register 0xBEEE)
“Unsigned 16 bits” = Unsigned 16 bits register
“Signed 16 bits” = 16 bits register with sign
“Float 32 bits” = Floating point single precision 32 bits (IEEE 754) register
“0x” = Hexadecimal Value

Default communication parameters, RS485: 38400 baud, 8N1.

Default communication parameters, USB: 38400 baud, 8N1.

RS485 register table

Name	Range	Interpretation of register	R/W	Default	Address
MachineID	/	MSB, LSB	R		40001
	Id_Code (Module ID)			0x42	Bit [15:8]
	Ext_Rev (Module version)				Bit [7:0]
FWREV	/	Word	R		40002
	Firmware Code				
Errors	/	Bit	R		40069

USER MANUAL – Z-DAQ-PID

	These bits aren't used			/	Bit [15:6]
	Over-scale range error for acquired input (over hardware limits): 0=there isn't; 1=there is			/	Bit 5
	Amplitude detection of acquired input signal: 0=amplitude is between input start scale and input end scale; 1=amplitude is less than input start scale			/	Bit 4
	Amplitude detection of acquired input signal: 0=amplitude is between input start scale and input end scale; 1=amplitude is greater than input end scale			/	Bit 3
	Input burn-out error (if bit40006.0=1 and the input is greater than input scale range): 0=there isn't; 1=there is.			/	Bit 2
	Temperature acquisition error in the thermocouple cold-junctions (if TC-type input): 0=there isn't; 1=there is			/	Bit 1
	Memory loss-of-data: 0=there isn't; 1=there is			/	Bit 0
Rejection Burn	/	Bit	R/W*		40006
	These bits aren't used			/	Bit[15:10]
	Rejection: 0b00=50Hz; 0b01=60Hz; 0b10=No rejection ("fast" sampling)			0b00	Bit [9:8]
	These bits aren't used			/	Bit [7:1]
	Burn-out enabling: 0=deactivated; 1=activated (if 1: fault output value is overwritten into output register)			0	Bit 0
Filter Cold-junction	/	Bit, LSB	R/W*		40005
	These bits aren't used			/	Bit [15:9]
	Cold-junction compensation (if TC-type input): 0=deactivated; 1=activated			0	Bit 8
	Filter applied to the acquired input signal: 0=deactivated; 1=filtering min-value; 19=filtering max-value			0	Bit [7:0]
IN Type	/	Word	R/W*		40003
	Input-type: 0=current; 1=voltage; 2=potentiometer; 3=TC J; 4=TC K; 5=TC R; 6=TC S; 7=TC T; 8=TC B; 9=TC E; 10=TC N; 11= 2-wires PT100; 12=3-wires PT100; 13=4-wires PT100; 14=2-wires NI100; 15=3-wires NI100; 16=4-wires NI100; 17=2-wires PT500; 18=3-wires PT500; 19=4-wires PT500; 20=2-wires PT1000; 21=3-wires PT1000; 22=4-wires PT1000; 23=millivoltmeter			0	

USER MANUAL – Z-DAQ-PID

Address	/	MSB, LSB	R/W*		40033
Parity					
	Address for RS485 (address of module/node if parameters are configurated by memory modality): from 0x01=1 to 0xFF=255			1	Bit [15:8]
	Parity for RS485: 0=there isn't; 1=even parity; 2=odd parity			0	Bit [7:0]
Baudrate	/	MSB, LSB	R/W*		40034
Delay					
	Baud-rate for RS485 (baud-rate of module/node if parameters are configurated by memory modality): 0=1200; 1=2400; 2=4800; 3=9600; 4=19200; 5=38400; 6=57600; 7=115200			38400	Bit [15:8]
	Delay for RS485 (delay of communication response: it represents the number of the pauses(*) between the end of Rx message and the start of Tx message): from 0x00=0 to 0xFF=255 (*)1 pause=6 characters			0	Bit [7:0]
Function modality	/	Word	R/W*		40007
	Functioning modality: 0=Conversion with PID, analog output 1=Conversion without PID, analog output 2=Conversion with PID, ON/OFF output 3=Conversion without PID, ON/OFF output 4=Manual, analog output 5=Manual, ON/OFF output			0	Bit [15:8]
IN-SS MSW	See "Input"	FP-32bit_MSW	R/W*		40008
IN-SS LSW		FP-32bit_LSW	R/W*		40009
	Input Start Scale: [mA] (if current-type input); [V] (if voltage-type input) [mV] (if millivoltmeter-type input); [%] (if potentiometer-type input); [°C] (if TC or RTD-type input)			0 [mA]	
IN-ES MSW	See "Input"	FP-32bit_MSW	R/W*		40010

USER MANUAL – Z-DAQ-PID

IN-ES LSW		FP-32bit_LSW	R/W*		40011
	Input End Scale: [mA] (if current-type input); [V] (if voltage-type input or millivoltmeter-type input); [%] (if potentiometer-type input); [°C] (if TC or RTD-type input)			20 [mA]	
IN Percent MSW	Between:0-1	FP-32bit_MSW	R		40110
IN Percent LSW		FP-32bit_LSW	R		40111
	Percent measure of input: [%] with reference to the Input Scale range (for selected input-type) (if it is equal to 0, it corresponds to the 0% of the Input Scale range; if it is equal to 1, it corresponds to the 100% of the Input Scale range)			/	
mA MSW	FP between: IN-SS, IN-ES	FP-32bit_MSW	R		40091
mA LSW		FP-32bit_LSW	R		40092
	Electric measure of input: [mA] (if current-type input)			/	
V MSW	FP between: IN-SS, IN-ES	FP-32bit_MSW	R		40093
V LSW		FP-32bit_LSW	R		40094
	Electric measure of input: [V] (if voltage-type input)			/	
POT MSW	FP between: IN-SS, IN-ES	FP-32bit_MSW	R		40099
POT LSW		FP-32bit_LSW	R		40100
	Electric measure of input: [%] (if potentiometer-type input)			/	
TC MSW	FP between: IN-SS, IN-ES	FP-32bit_MSW	R		40083
TC LSW		FP-32bit_LSW	R		40084
	Electric measure of input: [mV] (if TC-type input) without cold-junction compensation (if bit40005.8=0), with cold-junction compensation (if bit40005.8=1)			/	
TCT MSW	FP between: IN-SS, IN-ES	FP-32bit_MSW	R		40085

USER MANUAL – Z-DAQ-PID

TCT LSW		FP-32bit_LSW	R		40086
	Electric measure of input: [°C] (if TC-type input) with compensation				
CJ MSW	/	FP-32bit_MSW	R		40079
CJ LSW		FP-32bit_LSW	R		40080
	Equivalent electric measure of the cold-junction: [mV] (if TC-type input)			/	
RTDO MSW	/	FP-32bit_MSW	R		40087
RTDO LSW		FP-32bit_LSW	R		40088
	Electric measure of input: [Ω] (if RTD-type input)			/	
RTD MSW	FP between: IN-SS, IN-ES	FP-32bit_MSW	R		40089
RTD LSW		FP-32bit_LSW	R		40090
	Electric measure of input: [°C] (if RTD-type input)			/	
3wires-RTD MSW	/	FP-32bit_MSW	R		40095
3wires-RTD LSW		FP-32bit_LSW	R		40096
	Measure of the wire resistance for 3 wires RTD connection [Ω] (if RTD-type input)			/	
4wires-RTD MSW	/	FP-32bit_MSW	R		40097
4wires-RTD LSW		FP-32bit_LSW	R		40098
	Measure of the wire resistance for 4 wires RTD connection [Ω] (if RTD-type input)			/	
OUT Type Limiter	/	Bit	R/W*		40004
	These bits aren't used			/	Bit[15:13]

USER MANUAL – Z-DAQ-PID

	Output current type: 0=active current (the module supplies the loop); 1=passive current (the sensor supplies the loop)			0	Bit 12
	These bits aren't used			/	Bit [11:9]
	Output type: 0=current; 1=voltage			0	Bit 8
	These bits aren't used			/	Bit [7:1]
	Output limiter: 0=deactivated; 1=activated			0	Bit 0
OUT-SS MSW	See "Output"	FP-32bit_MSW	R/W*		40012
OUT-SS LSW		FP-32bit_LSW	R/W*		40013
	Output Start Scale: [mA] (if current-type output); [V] (if voltage-type output)			0 [mA]	
OUT-ES MSW	See "Output"	FP-32bit_MSW	R/W*		40014
OUT-ES LSW		FP-32bit_LSW	R/W*		40015
	Output End Scale: [mA] (if current-type output); [V] (if voltage-type output)			20 [mA]	
OUT MSW		FP-32bit_MSW	R		40105
OUT LSW		FP-32bit_LSW	R		40106
	Output value: [mA] (if current-type output); [V] (if voltage-type output)			/	
OUT		Word	R		40109
	Output value: [μA] (if current-type output); [mV] (if voltage-type output)			/	
OUT-Fault MSW		FP-32bit_MSW	R/W*		40020
OUT-Fault LSW		FP-32bit_LSW	R/W*		40021
	Fault output value (measure unit is the same of output) Reg.40105,40106 are equal to reg.40020,40021 if 40069.2=1 (there is input burn-out error) (if out type = analog)			0 [%]	
OUT-Manual	Between: 0; 10000	Word	R/W*		40107
	Output manual value [%·100] (if it is equal to 0, it corresponds to the 0% of the Output Scale range; if it is equal to 10000, it corresponds to the 100% of the Output Scale range); for selected output-type, see reg.40004 (if operating modality=manual, constant output)			0 [%]	

USER MANUAL – Z-DAQ-PID

Lim Inf MSW		FP-32bit_MSW	R/W*		40018
Lim Inf LSW		FP-32bit_LSW	R/W*		40019
	Output limiter lower limit (measure unit is the same of output)			0 (=0 [mA])	
Lim Sup MSW		FP-32bit_MSW	R/W*		40016
Lim Sup LSW		FP-32bit_LSW	R/W*		40017
	Limit superior of the output limiter (measure unit is the same of output)			1 (=20[mA])	
PID-sign		Bit	R/W*		40007
	PID regulation sign: 1=direct-type (cooling); 0=reverse-type (heating)			0	Bit [7:0]
Proportional Band		Word	R/W*		40025
	PID regulation proportional band [%], with reference to the Input Scale range (if operating modality=conversion with PID)			100%	
Integral time		Word	R/W*		40026
	PID regulation integral time [sec/10]. 0=there is no integral action (if operating modality=conversion with PID)			2400 [sec/10] (=240sec)	
Derivative time		Word	R/W*		40027
	PID regulation derivative time [sec/10]. 0=there is no derivative action (if operating modality=conversion with PID)			0 [sec/10]	
Set point MSW		FP-32bit_MSW	R/W*		40022
Set point LSW		FP-32bit_LSW	R/W*		40023
	Input set point for the PID regulation [%] with reference to the Input Scale range (if it is equal to 0, it corresponds to the 0% of the Input Scale range; if it is equal to 1, it corresponds to the 100% of the Input Scale range) (if operating modality=conversion with PID)			50%	
Process Value MSW		FP-32bit_MSW	R		40103

USER MANUAL – Z-DAQ-PID

Process Value LSW		FP-32bit_LSW	R		40104
	Process value for the PID regulation: [mA] (if current-type input); [V] (if voltage-type input); [mV] (if millivoltmeter-type input); [%] (if potentiometer-type input); [°C] (if TC or RTD-type input)			/	
Process value		Word	R		40108
	Process value for the PID regulation: [µA] (if current-type input); [mV] (if voltage-type input); [mV/100] (if millivoltmeter-type input); [%/100] (if potentiometer-type input); [°C/10] (if TC or RTD-type input)			/	
Offset		Word	R/W*		40024
	Output offset for the PID regulation [%/100] with reference to the Output Scale range (if it is equal to 0, it corresponds to the 0% of the Output Scale range; if it is equal to 1, it corresponds to the 100% of the Output Scale range) (if operating modality=conversion with PID)			5000 (=50%)	
Slew Rate enabling		Word	R/W*		40031
	Output slew rate: 0=deactivated; 1=activated			1	
Slew Rate		Word	R/W*		40032
	Output slew rate [%/sec]			100 [%/sec]	
Cycle Time	From 1 to 1310	Word	R/W*		40028
	Output cycle time [sec/10] (if output modality=ON/OFF)			300 (=30 sec)	
MinTime-High	From 1 to 1310	Word	R/W*		40029
	Minimum time of high-state output [sec/10] (if output modality=ON/OFF)			0 (=0 sec)	
MinTime-Low	From 1 to 1310	Word	R/W*		40030
	Minimum time of low-state output [sec/10] (if output modality=ON/OFF)			0 (=0 sec)	
Command	Command execution 0xC1A0 (decimal 49568) – Execute a hardware reset			0	40068

USER MANUAL – Z-DAQ-PID

	<p>0xBEEE (decimal 48878) – Save in Flash the actual Setup (registers with R/W*)</p> <p>Note: The Flash can be written for a Maximum of 20000 times.</p>		
--	---	--	--