





# INSTALLATION MANUAL

## R- 4AO-8DIDO series

### PRELIMINARY WARNINGS

The word **WARNING** preceded by the symbol  indicates conditions or actions that put the user's safety at risk. The word **ATTENTION** preceded by the symbol  indicates conditions or actions that could damage the instrument or connected equipment.

The warranty shall become null and void in the event of improper use or tampering with the module or devices supplied by the manufacturer as necessary for its correct operation, and if the instructions contained in this manual are not followed.

	<b>WARNING:</b> The full content of this manual must be read before any operation. The module must only be used by qualified electricians. Specific documentation is available using the QR-CODE shown on page 1.
	The module must be repaired and damaged parts replaced by the Manufacturer. The product is sensitive to electrostatic discharges. Take appropriate measures during any operation.
	Electrical and electronic waste disposal (applicable in the European Union and other countries with recycling). The symbol on the product or its packaging shows the product must be surrendered to a collection centre authorized to recycle electrical and electronic waste.



DOCUMENTATION



SENECA s.r.l.; Via Austria, 26 – 35127 – PADOVA – ITALY; Tel. +39.049.8705359 - Fax +39.049.8706287

### CONTACT INFORMATION

Technical support	support@seneca.it	Product information	sales@seneca.it
-------------------	-------------------	---------------------	-----------------

This document is the property of SENECA srl. Copies and reproduction are prohibited unless authorised.

The content of this document corresponds to the described products and technologies.

Stated data may be modified or supplemented for technical and/or sales purposes.

# MODULE LAYOUT

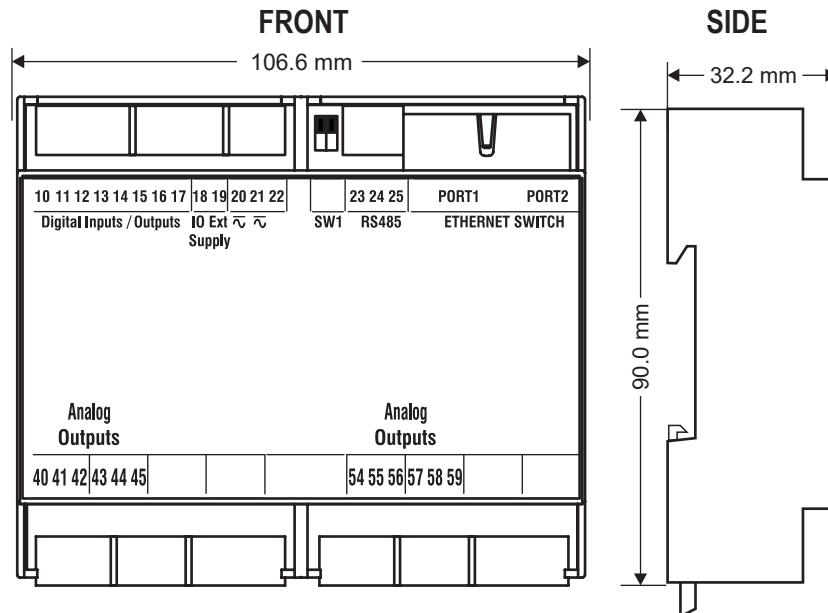



**Weight:** 170 g; **Enclosure:** UL94-V0 self-extinguishing PC/ABS material, black.

## SIGNALS VIA LED ON FRONT PANEL

LED	STATUS	LED meaning
IO1/IO8	On	Digital input/output active
	Off	Digital input/output not active
OUT SUP	On	Digital inputs/outputs powered
	Off	Digital inputs/outputs not powered
STS (Status only version R- 4AO-8DIDO)	On	IP address set
	Flashing	Waiting for the IP address from the DHCP
STS (Status only version R- 4AO-8DIDO-P)	On	IP address set
	Flashing	No configured IP address
COM (only version R- 4AO-8DIDO-P)	Off	No Profinet communication
	Flashing	Profinet communication present
FAIL	On	Digital output in FAIL
RX (only version R- 4AO-8DIDO)	On	RS485 port wiring error
	Flashing	Reception of data packet completed on RS485
TX (only version R- 4AO-8DIDO)	Flashing	Transmission of data packet completed on RS485
ETH TRF (Yellow)	Flashing	Packet transit on Ethernet port
ETH LNK (Green)	Flashing	Ethernet port connected

# TECHNICAL SPECIFICATIONS

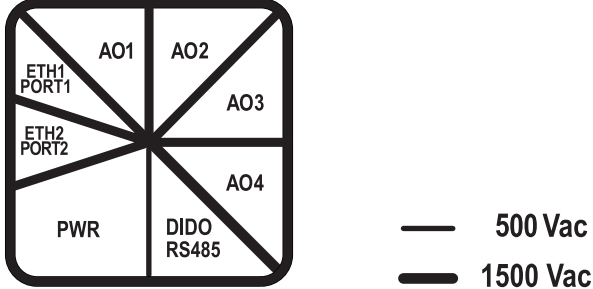
<b>CERTIFICATIONS</b>	  
<b>INSULATION</b>	
<b>POWER SUPPLY</b>	Voltage: 10 ÷ 40 Vdc; 19 ÷ 28 Vac; 50 ÷ 65 Hz; Absorption: 5.6 W
<b>ENVIRONMENTAL CONDITIONS</b>	Operating temperature: from -25°C to +65°C Humidity: 10% ÷ 90% non condensing. Storage temperature: from -30°C to +85°C Protection rating: IP20
<b>ASSEMBLY</b>	35mm DIN rail IEC EN60715
<b>CONFIGURATION</b>	With built-in WEB server (only version R- 4AO-8DIDO)
<b>CONNECTIONS/ COMMUNICATION PORTS</b>	3.5 mm pitch terminal block, 1.5 mm <sup>2</sup> max cable section 2 Ethernet (with LAN fault-bypass function) 100 base T on RJ45 1 RS485 port on terminals (only version R-4AO-8DIDO)
<b>DIGITAL INPUTS</b>	Number of channels: 8; Voltage: Threshold ON: > 11 Vdc; Threshold OFF:< 4 Vdc; Vmax: 24 Vdc; Impedance: 9 kΩ Compliant with IEC61131-2 type 3.
<b>DIGITAL OUTPUTS</b>	Number of channels: 8, MOSFET, PNP; Max voltage/current: 0.2 A ; 12 ÷ 24 Vdc
<b>ANALOG OUTPUTS</b>	Voltage outputs: -10.5 ÷ 10.5 V. Pilotable impedance > 600 Ohm Current outputs: 0÷21 mA. Pilotable impedance < 600 Ohm Number of channels: 4 Voltage output resolution: >12 bit (3 mV) Current output resolution: >12 bit (3 μA) Voltage output errors/current: Calibration: 0.1% of F.S. MAX Linearity: 0.05% of F.S. Thermal stability: 0.01%/°C of F.S. Noise: 1mV RMS / 7.5 μA RMS Response time: 5ms

# ELECTRICAL CONNECTIONS

## ⚠ CAUTION

The upper power supply limits must not be exceeded, as this could cause serious damage to the module.

Switch the module off before connecting inputs and outputs.

To meet the electromagnetic immunity requirements:

- use shielded signal cables;
- connect the shield to a preferential instrumentation earth system;
- separate shielded cables from other cables used for power installations (transformers, inverters, motors, etc.).

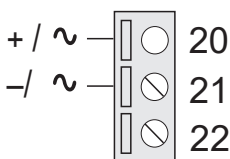
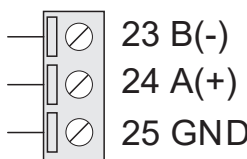
<p><b>POWER SUPPLY</b></p> 	<p><b>RS485 SERIAL PORT</b></p>  <p>Connection to the RS485 port. Polarity is not standardised and in some devices may be inverted.</p>	
--------------------------------------------------------------------------------------------------------------	------------------------------------------------------------------------------------------------------------------------------------------------------------------------------------------------------------------------------	--

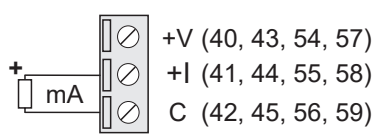
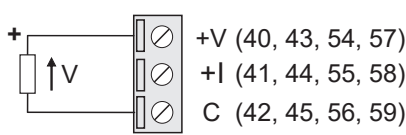
<p><b>ANALOG OUTPUTS</b></p> <p><b>CURRENT (mA)</b></p> 	<p><b>VOLTAGE (mV / V)</b></p> 	
--------------------------------------------------------------------------------------------------------------------------------------------	--------------------------------------------------------------------------------------------------------------------	--

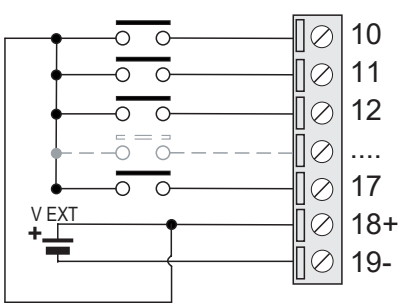
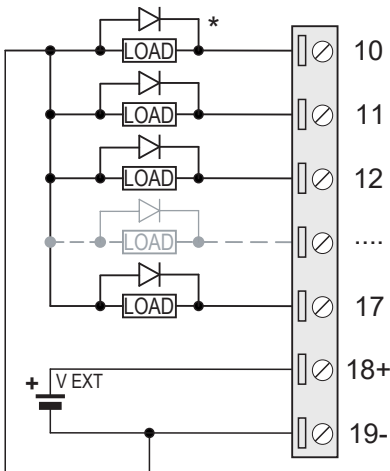
<p><b>DIGITAL INPUTS (PNP)</b> With external power</p>  <p>The digital inputs must be powered externally to function properly.(V EXT)</p>	<p><b>DIGITAL OUTPUTS (PNP)</b> With external power</p>  <p>The digital outputs must be powered externally to function properly (V EXT).</p> <p style="text-align: center;"><b>⚠ CAUTION</b></p> <p>* It is mandatory to use a protection DIODE for coils / relays for inductive loads, otherwise the device may fail and the manufacturer's warranty will be voided. The DIODE is normally supplied as an accessory by manufacturers of coils, relays, etc.</p>	
----------------------------------------------------------------------------------------------------------------------------------------------------------------------------------------------------------------------------------	---------------------------------------------------------------------------------------------------------------------------------------------------------------------------------------------------------------------------------------------------------------------------------------------------------------------------------------------------------------------------------------------------------------------------------------------------------------------------------------------------------------------------------------------------------	--

# SETTING THE DIP-SWITCHES

## ⚠ WARNING

The DIP-switch settings are read only at boot time. At each change, perform a restart.

For use and settings via DIP-SWITCH, see the user manual available on the website on the web page dedicated to the product.

### SW1 DIP-SWITCH: DEFAULT SETTINGS

SW1		
DIP1	OFF	DEFAULT SETTINGS
DIP2	OFF	

DIP-SWITCH SW1 is located on the front of the device.

# DAISY-CHAIN ETHERNET CONNECTION

## ⚠ CAUTION

### IT IS NOT ALLOWED TO CREATE LOOPS WITH ETHERNET CABLES

Using the daisy-chain connection it is not necessary to use switches to connect the devices. The following examples show the correct connections.

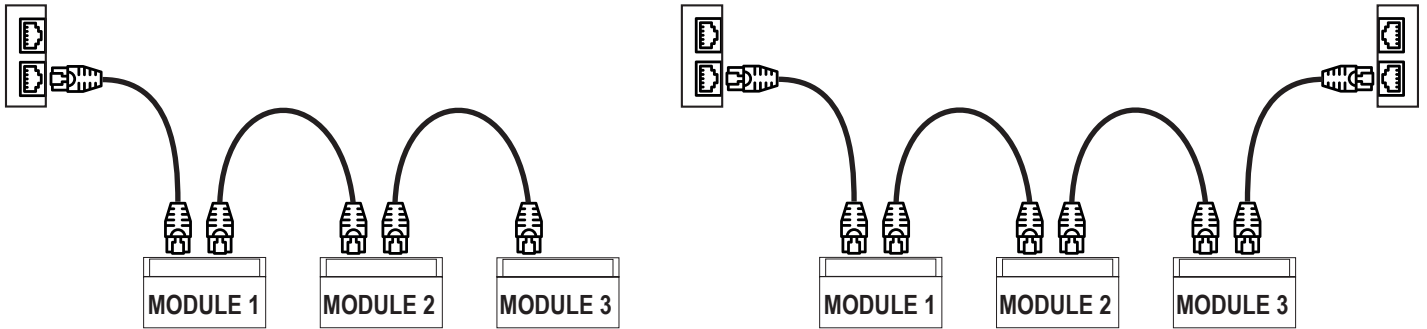

There must be no loops in the Ethernet cabling, otherwise the communication will not work. The modules and switches must be connected eliminating any loops. The following examples show the incorrect connections.

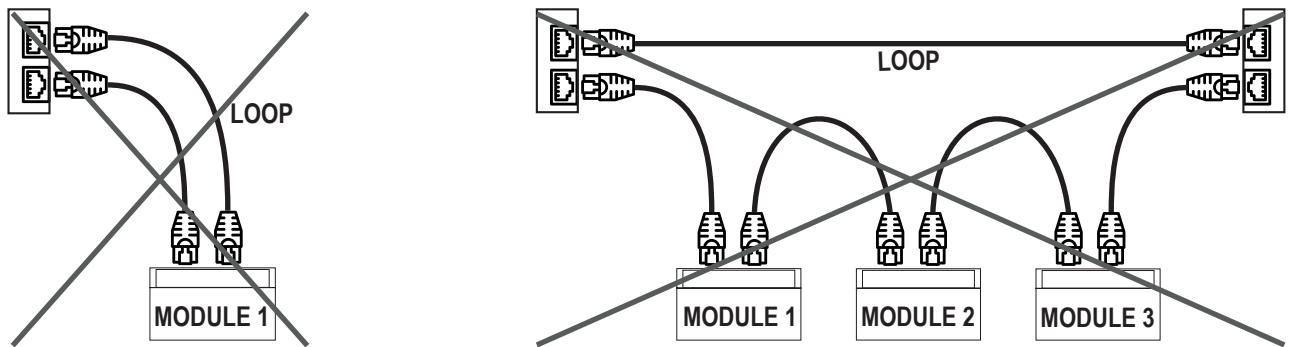

The LAN fault-bypass function allows you to keep the connection between the two Ethernet ports of the device ON, in the event of a power failure. If a device turns off, the chain is not interrupted and the devices downstream of the switched-off one will still be accessible. This function has a limited duration: the connection remains active for a few days, typically 4. The fault-bypass function requires that the sum of the lengths of the two cables connected to the switched off module is less than 100m.

## ETHERNET CONNECTION RULES

For the Ethernet cabling between the devices, the use of the unshielded CAT5 or CAT5e cable is required.

## FACTORY IP ADDRESS (ONLY R-4AO-8DIDO)

The default module IP address is static: 192. 168. 90. 101

## WEB SERVER

To access the maintenance Web Server, use the following credentials:

Default user: admin

Default password: admin

## ⚠ CAUTION

DO NOT USE DEVICES WITH THE SAME IP ADDRESS IN THE SAME ETHERNET NETWORK.