

# USER MANUAL

IIOT EDGE DEVICES



**SENECA S.r.l.**

**Via Austria 26 – 35127 – Z.I. - PADOVA (PD) - ITALY**  
**Tel. +39.049.8705355 – 8705355 Fax +39 049.8706287**

[www.seneca.it](http://www.seneca.it)

**ORIGINAL INSTRUCTIONS**

## CAUTION

SENECA does not guarantee that all specifications and/or aspects of the product and firmware, included in them, will meet the requirements of the actual final application even if the product referred to in this documentation is in compliance with the technological state of the art.

The user assumes full responsibility and/or risk with regard to the configuration of the product to achieve the intended results in relation to the specific installation and/or end application.

SENECA may, with prior agreement, provide consultancy services for the successful completion of the final application, but under no circumstances can it be held responsible for its proper functioning.

The SENECA product is an advanced product, the operation of which is specified in the technical documentation supplied with the product itself and/or can be downloaded, if desired prior to purchase, from the [www.seneca.it](http://www.seneca.it) website.

SENECA has a policy of continuous development and accordingly reserves the right to make and/or introduce - without prior notice - changes and/or improvements to any product described in this documentation.

The product described in this documentation may solely and exclusively be used by personnel qualified for the specific activity and in accordance with the relevant technical documentation, with particular attention being paid to the safety instructions.

Qualified personnel means personnel who, on the basis of their training, competence and experience, are able to identify risks and avoid potential hazards that could occur during the use of this product.

SENECA products may only be used for the applications and in the manner described in the technical documentation relating to the products themselves.

To ensure proper operation and prevent the occurrence of malfunctions, the transport, storage, installation, assembly, maintenance of SENECA products must comply with the safety instructions and environmental conditions specified in this documentation.

SENECA's liability in relation to its products is governed by the general conditions of sale, which can be downloaded from [www.seneca.it](http://www.seneca.it).

Neither SENECA nor its employees, within the limits of applicable law, will in any case be liable for any lost profits and/or sales, loss of data and/or information, higher costs incurred for goods and/or replacement services, damage to property and/or persons, interruption of activities and/or provision of services, any direct, indirect, incidental, pecuniary and non-pecuniary, consequential damages in any way caused and/or caused, due to negligence, carelessness, incompetence and/or other liabilities arising from the installation, use and/or inability to use the product.

### CONTACT US

Technical support	<a href="mailto:supporto@seneca.it">supporto@seneca.it</a>
Product information	<a href="mailto:commerciale@seneca.it">commerciale@seneca.it</a>

This document is the property of SENECA srl.  
Copies and reproduction are prohibited unless authorised

## Document revisions

DATE	REVISION	NOTES	AUTHOR
31/08/2020	0	First revision	MM
23/09/2020	1	Aggiunta la nuova funzione "Serial Trace" Aggiunta la nuova funzione "Reset di fabbrica" Aggiunta la nuova funzione "Copia Log su USB" da display e da webserver Spostato capitolo REGISTRI MODBUS I/O EMBEDDED	MM
23/09/2020	2	Aggiunto nuovo parametro "Sleep Timeout" in MQTT CONFIGURATION Aligned with firmware 104 revision	MM
26/11/2020	MI00557-3	Eliminated "optional" in the WI-FI characteristics	A. Zambolin
15/04/2021	MI00557-4	Allineato alla revisione fw 108	MM
25/08/2021	MI00557-5	Allineato alla revisione fw 109 Aggiunto prodotto R-PASS Eliminato parametro Bandwidth Limitation nel capitolo 21.11	MM
02/05/2022	MI00557-6	Allineato alla revisione fw 109 Added R-PASS product with 2 Ethernet ports	MM
06/05/2022	MI00557-7	Added R-PASS-S product aligned with fw 210 revision	MM
15/12/2022	MI00557-8	Added info on SNMP, OPC-UA protocol. Added R-COMM support Aligned with fw 223 version Added function block list for -S versions	MM
20/06/2023	MI00557-9	Additions by Seneca Service	AS / MM
28/06/2023	MI00557-10	Added new models Z-PASS1-RT, Z-PASS2-RT, Z-TWS4-RT, Z-PASS2-RT-S. Replaced VPN BOX with VPNBOX2 Aligned with SSD/R-PASS fw 232 revision Aligned with -RT fw 1012 revision	MM
03/07/2023	MI00557-11	Small corrections	AZ
20/07/2023	MI00557-12	Stated corrections to the chapter 11.2 (MQTT client)	MM
21/12/2023	MI00557-13	Added chapter "SMS controls"	AZ
14/11/2024	MI00557-14	Rewritten manual for new firmware version rev 3xxx Added model SSD-S Added model SSD-E Updated to rev fw 3100	MM
26/11/2024	MI00557-15	Updated to rev fw 3120 Script execution action addition	MM

**TABLE OF CONTENTS**

<b>1.</b>	<b>INTRODUCTION .....</b>	<b>10</b>
1.1.	FIRMWARE WITH OPEN SOURCE LPG .....	11
<b>2.</b>	<b>MODELS.....</b>	<b>11</b>
2.1.	MODEL DESCRIPTION.....	12
2.1.1.	SSD / SSD-S / SSD-E.....	12
2.1.2.	R-PASS / R-PASS-S / R-PASS-E.....	13
2.1.3.	Z-PASS1-RT / Z-TWS4-RT / Z-TWS4-RT-E.....	13
2.1.4.	Z-PASS2-RT-4G / Z-PASS2-RT-4G-S / Z-PASS2-RT-4G-E.....	15
2.2.	HARDWARE AND SOFTWARE OPTIONS .....	15
2.2.1.	SSD.....	15
2.2.2.	R-PASS.....	17
2.2.3.	Z-PASS1-RT / Z-TWS4-RT.....	19
2.2.4.	Z-PASS2-RT-4G.....	20
<b>3.</b>	<b>IP ADDRESSES .....</b>	<b>22</b>
3.1.	FACTORY IP ADDRESSES .....	22
3.2.	IP ADDRESS SEARCH.....	22
<b>4.</b>	<b>ACCESS TO THE WEBSERVERS OF THE DEVICES.....</b>	<b>23</b>
4.1.	CONFIGURATION WEBSERVER ACCOUNT.....	24
4.1.1.	CONFIGURATION WEBSERVER WITH “GUEST” ACCOUNT .....	24
4.1.2.	CONFIGURATION WEBSERVER WITH “OPERATOR” ACCOUNT.....	24
4.2.	FIRST ACCESS TO THE WEB SERVER .....	24
4.3.	WEBSERVER WITH VIRTUAL DISPLAY.....	25
4.4.	CONFIGURATION WEBSERVER.....	25
<b>5.</b>	<b>DATA ACQUISITION AND PROCESSING, ALARMS GENERATION AND SENDING, DATA SENDING .....</b>	<b>25</b>
5.1.	THE DATA BUS AND INDUSTRIAL PROTOCOLS.....	26
5.1.1.	MODBUS PROTOCOLS.....	27
5.1.2.	OPC- UA PROTOCOL.....	27
5.2.	SHARED MEMORY AND TAGS .....	28
5.3.	DATALOGGER.....	28
5.4.	TAG PROCESSING: LOGICAL RULES AND STRATON PLC.....	29
5.5.	CONNECTION TO CLOUDS VIA “EASY CLOUD” TECHNOLOGY .....	29
5.6.	ALARMS.....	30
<b>6.</b>	<b>GRAPHICAL DISPLAY OF DATA ON THE DISPLAY / VIRTUAL DISPLAY .....</b>	<b>30</b>
6.1.	INFORMATION BAR.....	31
6.2.	MENU.....	31
6.2.1.	SETUP .....	32
6.2.1.1.	NETWORK.....	32
6.2.1.2.	PAGES.....	32



6.2.1.3.	TAGS .....	34
6.2.1.4.	DISPLAY .....	34
6.2.1.5.	USERS .....	35
6.2.1.6.	SERIAL .....	36
6.2.1.7.	SNIFFER .....	36
6.2.1.8.	SNIFFER MODE CONFIGURATION STEPS .....	37
6.2.2.	ALARMS.....	38
6.2.3.	BUS .....	39
6.2.4.	MAINTENANCE .....	40
6.2.5.	CHART .....	41
<b>6.3.</b>	<b>TYPE OF WIDGETS .....</b>	<b>43</b>
6.3.1.	PAGE CHANGE .....	45
<b>6.4.</b>	<b>TYPE OF WIDGET PAGE .....</b>	<b>45</b>
<b>6.5.</b>	<b>SYNOPTIC PAGE TYPE .....</b>	<b>46</b>
6.5.1.	“ADD WIDGET” TOOL .....	47
6.5.2.	DATABASE OF SYMBOLS FOR THE SYNOPTIC PAGES .....	48
<b>6.6.</b>	<b>ALARMS.....</b>	<b>49</b>
<b>6.7.</b>	<b>VIRTUAL DISPLAY .....</b>	<b>50</b>
<b>6.8.</b>	<b>DOWNLOADING LOG FILES TO USB FLASH DRIVE.....</b>	<b>50</b>
<b>7.</b>	<b>INDUSTRIAL GATEWAY / ROUTER / FIREWALL .....</b>	<b>51</b>
7.1.	SERIAL ETHERNET GATEWAY .....	51
7.2.	MODBUS ETHERNET TO SERIAL GATEWAY .....	51
7.3.	TRANSPARENT ETHERNET TO SERIAL GATEWAY .....	52
7.3.1.	VIRTUAL COM WITH RFC 2217 SUPPORT .....	52
7.3.1.1.	SENECA ETHERNET TO SERIAL CONNECT .....	53
7.3.1.1.1.	INSTALLING THE SENECA SERIAL TO ETHERNET DRIVER .....	53
7.3.1.1.2.	COM PORT SELECTION FOR SENECA ETHERNET TO SERIAL TO CONNECT .....	56
7.3.1.1.3.	SENECA SERIAL TO ETHERNET CONFIGURATION.....	58
7.3.1.1.4.	CHANGING THE PORT NUMBER.....	58
7.3.1.1.5.	AUTOMATIC CONNECTION AT PC STARTUP .....	62
7.3.2.	SERIAL TUNNEL POINT ON TCP.....	62
7.3.3.	POINT--TO-POINT SERIAL TUNNEL ON UDP .....	63
<b>7.4.</b>	<b>MODBUS GATEWAY WITH SHARED MEMORY .....</b>	<b>63</b>
<b>8.</b>	<b>DEVICE CONFIGURATION VIA CONFIGURATION WEBSERVER .....</b>	<b>66</b>
8.1.	“SUMMARY” PAGE .....	66
8.2.	NETWORK AND SERVICES PAGE .....	66
8.2.1.	NETWORK SECTION .....	66
8.2.2.	WEB SERVER SECTION .....	67
8.2.3.	FILE TRANSFER SECTION .....	67
8.2.4.	DATA FOLDER SHARING SECTION.....	67
8.2.5.	NETWORK REDUNDANCY SECTION.....	67
8.2.6.	R-COMM SECTION (for R-PASS model only).....	68
8.2.7.	WATCHDOG SECTION .....	68
8.2.8.	DEBUG LOGS SECTION.....	68
<b>8.3.</b>	<b>PLC CONFIGURATION PAGE .....</b>	<b>69</b>
8.3.1.	STRATON PLC SECTION .....	69
8.3.2.	Real-Time Behaviour SECTION.....	70
<b>8.4.</b>	<b>PLC MODBUS CONF. PAGE.....</b>	<b>70</b>

8.4.1.	Modbus TCP Client SECTION .....	70
8.4.2.	Modbus Pass-through SECTION .....	71
<b>8.5.</b>	<b>SERIAL PORTS PAGE .....</b>	<b>71</b>
8.5.1.	COM1 SECTION (RS485/RS232/MBUS) .....	71
8.5.2.	COM2 SECTION (RS485).....	71
8.5.3.	COM4 SECTION (RS485).....	72
<b>8.6.</b>	<b>WI-FI CONFIGURATION PAGE.....</b>	<b>72</b>
<b>8.7.</b>	<b>I/O CONFIGURATION PAGE.....</b>	<b>73</b>
8.7.1.	Digital I/O Configuration SECTION .....	73
8.7.2.	Analog I/O Configuration SECTION .....	77
8.7.3.	Security Level SECTION .....	77
<b>8.8.</b>	<b>REAL TIME CLOCK SETUP PAGE.....</b>	<b>78</b>
8.8.1.	NTP SECTION .....	78
8.8.2.	RTC SECTION .....	78
<b>8.9.</b>	<b>GATEWAY CONFIGURATION PAGE .....</b>	<b>78</b>
8.9.1.	Modbus Shared Memory SECTION .....	79
8.9.2.	Modbus Ethernet to Serial e Modbus Shared Memory SECTION .....	80
8.9.3.	COM0, COM1, COM2, COM4 SECTION (DEPENDSING ON THE MODEL) .....	80
8.9.3.1.	COM0 (USB) .....	80
8.9.3.1.	COM1 (RS232/RS485) COM2 (RS485) COM4 (RS485) .....	81
8.9.3.1.1.	COM1/COM2/COM4 Modbus Ethernet to Serial .....	81
8.9.3.1.2.	COM1/COM2/COM4 Transparent .....	81
8.9.3.1.2.1.	COM1/COM2/COM4 VIRTUAL COM .....	81
8.9.3.1.2.2.	COM1/COM2/COM4 SERIAL TUNNEL POINT TO POINT ON TCP/UDP .....	82
8.9.3.1.2.1.	COM1/COM2/COM4 MODBUS SHARED GATEWAY .....	82
<b>8.10.</b>	<b>VPN CONFIGURATION PAGE .....</b>	<b>83</b>
8.10.1.	VPN FILES SECTION .....	83
8.10.2.	OPEN VPN SECTION .....	85
8.10.3.	VPN BOX SECTION.....	86
<b>8.11.</b>	<b>OPC-UA SERVER CONFIGURATION PAGE.....</b>	<b>87</b>
8.11.1.	OPC- UA Server Conf. SECTION .....	87
8.11.1.1.	OPC- UA SERVER CERTYIFICATES SECTION .....	88
<b>8.12.</b>	<b>OPC-UA CLIENT CONFIGURATION PAGE .....</b>	<b>89</b>
<b>8.13.</b>	<b>SNMP CONFIGURATION PAGE .....</b>	<b>90</b>
8.13.1.	GENERAL CONFIGURATION SECTION .....	90
8.13.2.	COMMUNITIES SECTION .....	90
8.13.3.	HOSTS SECTION .....	90
<b>8.14.</b>	<b>USERS CONFIGURATIONS PAGE.....</b>	<b>91</b>
<b>8.15.</b>	<b>ROUTER CONFIGURATION PAGE .....</b>	<b>91</b>
<b>8.16.</b>	<b>PORT MAPPING RULES PAGE .....</b>	<b>92</b>
<b>8.17.</b>	<b>NAT 1:1 RULES PAGE .....</b>	<b>92</b>
<b>8.18.</b>	<b>STATIC ROUTES PAGE .....</b>	<b>94</b>
<b>8.19.</b>	<b>MOBILE NETWORK PAGE (Mobile Configuration) .....</b>	<b>95</b>
8.19.1.	SIM SECTION .....	95
8.19.2.	OPERATOR SELECTOR SECTION .....	95
8.19.3.	DATA CONNECTION SECTION .....	96
<b>8.20.</b>	<b>DDNS CONFIGURATION PAGE (Mobile Configuration).....</b>	<b>96</b>
<b>8.21.</b>	<b>TCP SERVERS PAGE (Shared Memory Tag Conf.).....</b>	<b>97</b>
<b>8.22.</b>	<b>TAG SETUP PAGE (Shared Memory Tag Conf.) .....</b>	<b>98</b>
<b>8.23.</b>	<b>TAG VIEW PAGE (Shared Memory Tag Conf.) .....</b>	<b>100</b>
<b>8.24.</b>	<b>DB DEVICE CUSTOM PAGE (Shared Memory Tag Conf.).....</b>	<b>100</b>

8.25.	ALARM CONFIGURATION PAGE (Alarms) .....	100
8.26.	ALARM SUMMARY PAGE (Alarms) .....	103
8.27.	ALARM HISTORY PAGE (Alarms) .....	103
8.28.	SD/USB TRANSFER CONFIGURATION PAGE (CLIENT PROTOCOLS) .....	103
8.29.	FTP CONFIGURATION PAGE (CLIENT PROTOCOLS) .....	104
8.30.	EMAIL CONFIGURATION PAGE (CLIENT PROTOCOLS) .....	105
8.31.	HTTP CONFIGURATION (CLIENT PROTOCOLS) .....	107
8.32.	MQTT CONFIGURATION (CLIENT PROTOCOLS) .....	108
8.33.	PHONEBOOK PAGE (LOGIC CONFIGURATION) .....	115
8.34.	MESSAGE CONFIGURATION PAGE (LOGIC CONFIGURATION) .....	116
8.35.	TIMER CONFIGURATION PAGE (LOGIC CONFIGURATION) .....	116
8.36.	RULE SCRIPTS PAGE (LOGIC CONFIGURATION) .....	117
8.37.	RULE MANAGEMENT PAGE (LOGIC CONFIGURATION) .....	117
8.37.1.	RULE CONFIGURATION .....	117
8.37.2.	IF CONDITION: TYPE .....	118
8.37.3.	IF CONDITION OPERATOR .....	124
8.37.4.	THEN/ELSE ACTION .....	124
8.38.	GENERAL SETTINGS PAGE (DATALOGGER) .....	132
8.39.	GROUP CONFIGURATION PAGE .....	133
8.40.	CLOUD CONFIGURATION PAGE .....	134
8.40.1.	CUMULOCITY .....	134
8.40.2.	DIREL ADM4.0 .....	135
8.40.3.	ONBOARD .....	136
8.41.	METER-BUS (M-BUS) PROTOCOL .....	136
8.41.1.	M-BUS SCAN .....	137
8.41.2.	"CREATE CONFIGURATION" BUTTON .....	139
8.41.3.	M-Bus Configuration .....	139
8.41.4.	IMPORTING THE CONFIGURATION INTO STRATON .....	140
8.41.5.	DELETING UNUSED MBUS VARIABLES .....	148
8.41.6.	REPLACING AN M-BUS DEVICE .....	149
8.41.7.	ADDING AN M-BUS DEVICE .....	149
8.41.8.	DELETING AN MBUS DEVICE .....	149
8.41.9.	"TAG ERROR REPORT" SPECIAL TAG .....	150
8.42.	CUSTOM IMAGES PAGE (GUI CONFIGURATION) .....	150
8.43.	ETHERNET INTERFACES PAGE (MAINTENANCE) .....	150
8.44.	MODBUS SERIAL TRACE PAGE (MAINTENANCE) .....	150
8.45.	FW VERSION PAGE (MAINTENANCE) .....	151
8.46.	FIRMWARE UPGRADE PAGE (MAINTENANCE) .....	151
8.47.	MANAGEMENT CONF. PAGE (MAINTENANCE) .....	151
8.48.	LICENCE MANAGEMENT (MAINTENANCE) .....	151
8.49.	MODBUS MODULES (MAINTENANCE) .....	151
8.50.	PLC MODE CONFIGURATION (MAINTENANCE) .....	152
<b>9.</b>	<b>VPN .....</b>	<b>153</b>
9.1.	VPN "SINGLE LAN" ALWAYS ON .....	155
9.2.	VPN "POINT TO POINT" ON DEMAND .....	156
9.3.	DISABLING THE VPN CONNECTION .....	156
9.4.	CONFIGURATION FILE FOR USE WITH OPEN VPN .....	157
<b>10.</b>	<b>COMMUNICATION NETWORK REDUNDANCY .....</b>	<b>158</b>

<b>11.</b>	<b>MQTT CLIENT PROTOCOL.....</b>	<b>158</b>
11.1.	MQTT PROTOCOL IMPLEMENTATION FEATURES.....	159
11.2.	FEATURES OF THE MQTT PROTOCOL IMPLEMENTATION OF THE STRATON PLC.....	159
11.2.1.	PARAMETERS OF THE MQTT PROTOCOL FROM THE PLC PROGRAM.....	159
11.2.2.	MANAGING MULTIPLE MQTT CONNECTIONS.....	161
11.2.3.	MQTT CONFIGURATION OF SSL/TLS RETRYs.....	161
11.2.4.	STATIC AND DYNAMIC CLIENT CERTIFICATES.....	162
11.2.5.	CHANGING MQTT PARAMETERS IN RUNTIME VIA FILE.....	163
<b>12.</b>	<b>LOGICAL RULES.....</b>	<b>163</b>
12.1.	CREATION OF A PROGRAM WITH LOGICAL RULES.....	165
<b>13.</b>	<b>THE STRATON PLC.....</b>	<b>175</b>
13.1.	IMPORTING TAGS INTO THE PLC (PLC MODE = SHARED).....	177
<b>14.</b>	<b>SCRIPT EXECUTION IN LOGICAL RULES.....</b>	<b>185</b>
14.1.	Reading and writing a Tag from a script.....	186
14.1.1.	Tag_read.....	186
14.1.2.	Tag_write.....	187
14.2.	EXAMPLE OF A PYTHON SCRIPT.....	187
14.3.	PYTHON MODULES INSTALLED.....	188
<b>15.</b>	<b>ENERGY PROTOCOLS FOR THE STRATON PLC.....</b>	<b>190</b>
<b>16.</b>	<b>MANUAL INSTALLATION OF LIBRARIES IN STRATON.....</b>	<b>192</b>
<b>17.</b>	<b>CYBERSECURITY.....</b>	<b>195</b>
<b>18.</b>	<b>WRITING FROM CLOUD TO DEVICE.....</b>	<b>195</b>
18.1.	WRITING TAGS FROM CLOUD TO DEVICE VIA MQTT.....	195
18.2.	SENDING ACTION COMMANDS FROM THE CLOUD TO THE DEVICE VIA MQTT.....	197
<b>19.</b>	<b>SFTP ACCESS.....</b>	<b>199</b>
<b>20.</b>	<b>MAINTENANCE MODE.....</b>	<b>201</b>
<b>21.</b>	<b>SMS COMMANDS.....</b>	<b>201</b>
21.1.	PPP ON.....	202
21.2.	PPP OFF.....	202
21.3.	PPP IP.....	203
21.4.	PPP CNF.....	204
21.5.	VPN ON.....	205
21.6.	VPN OFF.....	206
21.7.	VPN CNF.....	206
21.8.	FWL ON.....	207

21.9.	FWL OFF .....	207
21.10.	GET DIN.....	207
21.11.	GET DOUT.....	208
21.12.	SET DOUT .....	208
21.13.	SET PULSE .....	209
21.14.	SET USER.PHONE .....	210
21.15.	RESET PHONE .....	211
21.16.	SET USER.EMAIL .....	211
21.17.	RESET EMAIL .....	212
21.18.	STATUS.....	212
21.19.	GET GPS .....	213
21.20.	RESET .....	213
21.21.	GET TAG .....	213
21.22.	SET TAG.....	214
21.23.	OVPN ON.....	215
21.24.	OVPN OFF .....	215
21.25.	CLEAN LOGS.....	215
<b>22.</b>	<b>DEVICE FIRMWARE UPDATE .....</b>	<b>216</b>
22.1.	FIRMWARE UPDATE FROM USB STICK.....	216
<b>23.</b>	<b>FACTORY RESET.....</b>	<b>216</b>
23.1.	FACTORY RESET FOR SSD .....	216
23.2.	FACTORY RESET FOR R-PASS AND R-PASS-S.....	218
23.3.	FACTORY RESET FOR Z-PASS1-RT, Z-PASS2-RT, Z-TWS4-RT-S, Z-PASS2-RT-S .....	218
<b>24.</b>	<b>MODBUS ADDRESSES OF EMBEDDED I/OS OF DEVICES.....</b>	<b>218</b>
24.1.	MODBUS ADDRESSES OF SSD I/Os.....	218
24.2.	MODBUS ADDRESSES OF R-PASS I/Os .....	219
24.3.	MODBUS ADDRESSES OF Z-PASS1-RT, Z-PASS2-RT I/Os.....	219
<b>25.</b>	<b>“UA EXPERT” CLIENT CONFIGURATION.....</b>	<b>220</b>

## 1. INTRODUCTION



### ATTENTION!

This user manual extends the information from the installation manual to the configuration of the device. Use the installation manual for more information.



### ATTENTION!

In any case, SENECA s.r.l. or its suppliers will not be responsible for the loss of data/revenue or consequential or incidental damages due to negligence or bad/improper management of the device, even if SENECA is well aware of these possible damages.

**SENECA, its subsidiaries, affiliates, group companies, suppliers and distributors do not guarantee that the functions fully meet the customer's expectations or that the device, firmware and software should have no errors or operate continuously.**

SENECA IloT EDGE gateways are key components of industrial automation and offer a range of features that drive efficiency and reliability. These gateways act as digital sentinels of the factory, combining supervision, diagnostics, processing and data storage in a single compact unit.

**Supervision** is the first line of defence, as IloT EDGE gateways continuously monitor the health and performance of connected field devices, collect real-time data and provide insights that enable predictive maintenance, reducing downtime and operating costs.

**Diagnostic capabilities** are also key. These gateways use advanced analyses to detect anomalies and deviations from expected behaviour. In this way, they enable proactive problem resolution, preventing problems before they escalate. The result is higher uptime and more consistent production.

**Processing power** is another key feature. IloT EDGE gateways have the processing power to perform data processing operations on-the-fly. They can pre-process data at the source, filtering, aggregating, or transforming it before sending it to the cloud or central systems. This minimizes bandwidth usage and latency, maximizing the value of the data.

**Data storage** is essential for buffering and storing data locally. In the event of network outages, these gateways ensure that critical data is not lost, and also facilitate historical analysis and reporting, enabling informed decisions.

**Real-time management** of field devices is the hallmark of these gateways, they can remotely configure, update, and control industrial equipment, allowing operators to respond quickly to changing conditions or emergency situations. This capability simplifies operations and improves overall system resilience.

**Security** is key, and IloT EDGE gateways excel at this. They establish secure VPN connections to central control systems, encrypting data in transit, and also apply access controls, ensuring that only authorized personnel can interact with them, safeguarding against cyber threats. These gateways comply with the most stringent cybersecurity standards, starting with OWASP penetration testing, NIST 800 115 Risk Analysis, and IEC 62443. IloT EDGE gateways are indispensable in today's industrial environments. They serve as front-line intelligence, providing data supervision, diagnostics, processing, and storage. Secure VPN connections and real-time device management make them the linchpin of efficient, responsive, and secure industrial operations.

## 1.1. FIRMWARE WITH OPEN SOURCE LPG

Firmwares can contain Open Source software under GPL contract. According to Section 3b of the GPL, it is possible to have the source code for these parts. The source code with the Open Source software license terms can be obtained upon request from Seneca s.r.l.

Send your request to [supporto@seneca.it](mailto:supporto@seneca.it) with the subject "Open Source".

## 2. MODELS

The Edge IIOT Gateway series consists of the following models:

MODEL	DIGITAL I/O	ANALOG INPUTS	DISPLAY	PLC STRATON	MODEM 4G	INTEGRATED UPS	SERIAL PORTS	ETHERNET PORTS	CAN PORT	WIFI	IEC61850 IEC60870 PROTOCOLS
SSD	2 DIDO	NO	7" TOUCH + VIRTUAL	NO	NO	NO	2	2	NO	YES	NO
SSD-S	2 DIDO	NO	7" TOUCH + VIRTUAL	YES	NO	NO	2	2	NO	YES	NO
SSD-E	2 DIDO	NO	7" TOUCH + VIRTUAL	YES	NO	NO	2	2	NO	YES	YES
R-PASS	4DI 4DO	2	VIRTUAL	NO	OPTIONAL	OPTIONAL	2	4 (1+3 in switch)	YES	OPTIONAL	NO
R-PASS-S	4DI 4DO	2	VIRTUAL	YES	OPTIONAL	OPTIONAL	2	4 (1+3 in switch)	YES	OPTIONAL	NO
R-PASS-E	4DI 4DO	2	VIRTUAL	YES	OPTIONAL	OPTIONAL	2	4 (1+3 in switch)	YES	OPTIONAL	YES
Z-PASS1-RT	6 DIDO	2	VIRTUAL	NO	NO	NO	3	2	YES	NO	NO
Z-TWS4-RT	6 DIDO	2	VIRTUAL	YES	NO	NO	3	2	YES	NO	NO
Z-TWS4-RT-E	6 DIDO	2	VIRTUAL	YES	NO	NO	3	2	YES	NO	YES
Z-PASS2-RT-4G	6 DIDO	2	VIRTUAL	NO	YES	NO	3	2	YES	NO	NO
Z-PASS2-RT-4G-S	6 DIDO	2	VIRTUAL	YES	YES	NO	3	2	YES	NO	NO
Z-PASS2-RT-4G-E	6 DIDO	2	VIRTUAL	YES	YES	NO	3	2	YES	NO	YES

N.B. Depending on the model, the CAN port may be available but not managed by the firmware revision.

## 2.1. MODEL DESCRIPTION

### 2.1.1.SSD / SSD-S / SSD-E



Surprise Smart Display is a 7-inch HMI touch-sensitive colour display (capacitive touch panel), with resolution 800 x 480 and LED backlight

It is an operator panel designed to control and monitor devices, plants or production lines.

Smart Display also offers extensive connectivity thanks to the features of Industrial Gateway, Serial Device Server, Bridge and WI-FI, it is also equipped with an ever-increasing number of industrial protocols.

A novelty introduced in the industrial automation world is the possibility to display variables of the Modbus RTU protocol in a completely passive mode (serial sniffer).

The preloaded software application allows the display of parameters, the sending of commands, the configuration of tags, communication, individual video pages and alarm management.

Includes support for the latest version of LET'S VPN for the maintenance and monitoring of remote devices.

The -S version is also available which includes the PLC Straton IEC 61131.

In addition to including the Straton PLC, the -E version has licenses for energy management protocols. IEC61850 and IEC60870



2.1.2.R-PASS / R-PASS-S / R-PASS-E



R-PASS is a device designed for the control and monitoring of the operation of devices, systems or production lines, it also offers extensive connectivity thanks to the Industrial Gateway, Serial Device Server, Bridge and WI-FI functions, it is also equipped with a continuously increasing number of industrial protocols especially in the IOT sector.

A novelty introduced in the industrial automation world is the possibility to display variables of the Modbus RTU protocol in a completely passive mode (serial sniffer).

It is also equipped with a virtual display accessible from any device via a web browser.

Includes support for the latest version of LET'S VPN for the maintenance and monitoring of remote devices.

The -S version is also available which includes the PLC Straton IEC 61131.

It is possible to connect to the device the R-COMM option which includes a 4G modem and a UPS (optional).

The model with 4 Ethernet ports is available, with and without WIFI.

For more information on the Straton PLC refer to the website: <https://straton-plc.com/en/>

In addition to including the Straton PLC, the -E version has licenses for energy management protocols. IEC61850 and IEC60870

2.1.3.Z-PASS1-RT / Z-TWS4-RT / Z-TWS4-RT-E



Z-PASS1-RT/Z-TWS4-RT is a device designed for the control and monitoring of the operation of devices, systems or production lines, it also offers extensive connectivity thanks to the Industrial Gateway, Serial Device

Server and Bridge functions, it is also equipped with a number of continuously increasing industrial protocols especially in the IOT sector.

A novelty introduced in the industrial automation world is the possibility to display variables of the Modbus RTU protocol in a completely passive mode (serial sniffer).

It is also equipped with a virtual display accessible from any device via a web browser.

Includes support for the latest version of LET'S VPN for the maintenance and monitoring of remote devices.

The Z-TWS4-RT version is also available which includes the PLC Straton IEC 61131.

For more information on the Straton PLC refer to the website: <https://straton-plc.com/en/>

In addition to including the Straton PLC, the -E version has licenses for energy management protocols. IEC61850 and IEC60870

2.1.4.Z-PASS2-RT-4G / Z-PASS2-RT-4G-S / Z-PASS2-RT-4G-E



Z-PASS2-RT-4G is a device designed for the control and monitoring of the operation of devices, systems or production lines, it also offers extensive connectivity thanks to the Industrial Gateway, Serial Device Server and Bridge functions, it is also equipped with a number of continuously increasing industrial protocols especially in the IOT sector.

A novelty introduced in the industrial automation world is the possibility to display variables of the Modbus RTU protocol in a completely passive mode (serial sniffer).

It is also equipped with a virtual display accessible from any device via a web browser.

Includes support for the latest version of LET'S VPN for the maintenance and monitoring of remote devices.

It integrates a latest generation universal 4G modem.

The -S version is also available which includes the PLC Straton IEC 61131.

For more information on the Straton PLC refer to the website: <https://straton-plc.com/en/>

In addition to including the Straton PLC, the -E version has licenses for energy management protocols IEC61850 and IEC60870

2.2. HARDWARE AND SOFTWARE OPTIONS

The devices are available in various hardware formats and with different software features.

All software features can be purchased at the time of ordering or at a later time. The software features are unlocked by entering a key in the appropriate page of the device's web server.

2.2.1.SSD

Smart Display has the following hardware options:

HARDWARE OPTIONS	DESCRIPTION
SMART DISPLAY	7" DISPLAY WITH CAPACITIVE TOUCH NR 2 INGRESSO DIGITALE NR 2 USCITE DIGITALI

	No. 2 INDEPENDENT ETHERNETs WI-FI / ROUTER WI-FI No. 1 USB HOST PORT
Z-MBUS	MBUS PROTOCOL CONVERTER (METERBUS)

And it is possible to purchase the licenses of the following software options (the packages can be activated even more than one at the same time), by contacting Seneca directly.

<b>SOFTWARE OPTIONS</b>	<b>DESCRIPTION</b>
PACKAGE INCLUDED	Graphic display with widgets and synoptics  Virtual display with widgets and synoptics  Datalogger max 2000 tags with scaling  Alarms  Gateway/Router/Firewall  Gateway ethernet-serial  Serial Sniffer  Modbus TCP Client/Server protocol  Modbus RTU Master/Slave protocol  OPC-UA server protocol
IOT" PACKAGE	HTTP and MQTT protocol for cloud connection" with "Easy Cloud" technology
LOGIC" PACKAGE	Programmable logics through "IF THEN ELSE"  Remote Alarming
SENECA LET'S" VPN PACKAGE	Simplified VPN connection via "Seneca LET's VPN" environment and VPNBOX2 support Or Open VPN Standard

STRATON (-S) PLC PACKAGE	Allows you to activate the Straton PLC IEC 61131 Additional protocols provided: Modbus RTU, Modbus TCP-IP, MQTT, OPC-UA Client, MeterBus, S7 Client, SNMP
ENERGY PROTOCOL PACKAGE (-E)	Allows you to activate the Straton PLC and the licenses for the additional protocols IEC61850, IEC60870, Modbus RTU, Modbus TCP-IP, MQTT, OPC-UA Client, MeterBus, S7 Client, SNMP

### 2.2.2.R-PASS

R-PASS has the following hardware options:

HARDWARE OPTIONS	DESCRIPTION
R-PASS	NR 4 INGRESSO DIGITALE NR 4 USCITE DIGITALI No. 4 TOTAL: Ni. 1 INDEPENDENT ETHERNET + No. 3 IN SWITCH BETWEEN THEM No. 1 USB HOST PORT
R-PASS-W	NR 4 INGRESSO DIGITALE NR 4 USCITE DIGITALI No. 4 TOTAL: No. 1 INDEPENDENT ETHERNET + 3 IN SWITCH BETWEEN THEM WIFI
R-COMM-0-4GWW	4G GLOBAL MODEM
R-COMM-B-4GWW	4G GLOBAL MODEM + BATTERY POWERED UPS
Z-MBUS	MBUS PROTOCOL CONVERTER (METERBUS)

And it is possible to purchase the licenses of the following software options (the packages can be activated even more than one at the same time), by contacting Seneca directly.

SOFTWARE OPTIONS	DESCRIPTION
PACKAGE INCLUDED	Virtual display with widgets and synoptics

	<p>Datalogger max 2000 tags with scaling</p> <p>Alarms</p> <p>Gateway/Router/Firewall</p> <p>Gateway ethernet-serial</p> <p>Serial Sniffer</p> <p>Modbus TCP Client/Server protocol</p> <p>Modbus RTU Master/Slave protocol</p> <p>OPC-UA server protocol</p> <p>HTTP and MQTT protocol for cloud connection” with “Easy Cloud” technology</p> <p>Programmable logics through "IF THEN ELSE"</p> <p>Simplified VPN connection via "Seneca LET's VPN" environment and VPNBOX2 support Or Open VPN Standard</p>
<p>STRATON (-S) PLC PACKAGE</p>	<p>Allows you to activate the Straton PLC IEC 61131</p> <p>Additional protocols provided: Modbus RTU, Modbus TCP-IP, MQTT, OPC-UA Client, MeterBus, S7 Client, SNMP</p>
<p>ENERGY PROTOCOL PACKAGE (-E)</p>	<p>Allows you to activate the Straton PLC and the licenses for the additional protocols IEC61850, IEC60870, Modbus RTU, Modbus TCP-IP, MQTT, OPC-UA Client, MeterBus, S7 Client, SNMP</p>

**2.2.3.Z-PASS1-RT / Z-TWS4-RT**

Z-PASS1-RT / Z-TWS4-RT has the following hardware options:

<b>HARDWARE OPTIONS</b>	<b>DESCRIPTION</b>
Z-PASS1-RT / Z-TWS4-RT	No. 6 CONFIGURABLE DIGITAL INPUT/OUTPUT No. 2 ANALOG INPUT 0-10V / 0-20 mA No. 2 INDEPENDENT ETHERNETs No. 1 USB HOST PORT No. 1 SLOT SD CARD
Z-MBUS	MBUS PROTOCOL CONVERTER (METERBUS)

<b>SOFTWARE OPTIONS</b>	<b>DESCRIPTION</b>
PACKAGE INCLUDED	Virtual display with widgets and synoptics  Datalogger max 2000 tags with scaling  Alarms  Gateway/Router/Firewall  Gateway ethernet-serial  Serial Sniffer  Modbus TCP Client/Server protocol  Modbus RTU Master/Slave protocol  OPC-UA server protocol  HTTP and MQTT protocol for cloud connection" with "Easy Cloud" technology  Programmable logics through "IF THEN ELSE"

	Simplified VPN connection via "Seneca LET's VPN" environment and VPNBOX2 support Or Open VPN Standard
STRATON (-S) PLC PACKAGE (ALREADY INCLUDED IN THE Z-TWS4-RT MODEL ONLY)	Allows you to activate the Straton PLC IEC 61131 Additional protocols provided: Modbus RTU, Modbus TCP-IP, MQTT, OPC-UA Client, MeterBus, S7 Client, SNMP
ENERGY PROTOCOL PACKAGE (-E)	Allows you to activate the Straton PLC and the licenses for the additional protocols IEC61850, IEC60870, Modbus RTU, Modbus TCP-IP, MQTT, OPC-UA Client, MeterBus, S7 Client, SNMP

#### 2.2.4.Z-PASS2-RT-4G

Z-PASS2-RT-4G has the following hardware options:

HARDWARE OPTIONS	DESCRIPTION
Z-PASS2-RT-4G	No.1 4G GLOBAL MODEM + GNSS No. 6 CONFIGURABLE DIGITAL INPUT/OUTPUT No. 2 ANALOG INPUT 0-10V / 0-20 mA No. 2 INDEPENDENT ETHERNETs No. 1 USB HOST PORT No. 1 SLOT SD CARD
Z-MBUS	MBUS PROTOCOL CONVERTER (METERBUS)

SOFTWARE OPTIONS	DESCRIPTION
PACKAGE INCLUDED	Virtual display with widgets and synoptics  Datalogger max 2000 tags with scaling  Alarms



	<p>Gateway/Router/Firewall</p> <p>Serial Sniffer</p> <p>Gateway ethernet-serial</p> <p>Modbus TCP Client/Server protocol</p> <p>Modbus RTU Master/Slave protocol</p> <p>OPC-UA server protocol</p> <p>HTTP and MQTT protocol for cloud connection" with "Easy Cloud" technology</p> <p>Programmable logics through "IF THEN ELSE"</p> <p>Simplified VPN connection via "Seneca LET's VPN" environment and VPNBOX2 support Or Open VPN Standard</p>
<p>STRATON (-S) PLC PACKAGE</p>	<p>Allows you to activate the Straton PLC IEC 61131</p> <p>Additional protocols provided: Modbus RTU, Modbus TCP-IP, MQTT, OPC-UA Client, MeterBus, S7 Client, SNMP</p>
<p>ENERGY PROTOCOL PACKAGE (-E)</p>	<p>Allows you to activate the Straton PLC and the licenses for the additional protocols IEC61850, IEC60870, Modbus RTU, Modbus TCP-IP, MQTT, OPC-UA Client, MeterBus, S7 Client, SNMP</p>

### 3. IP ADDRESSES

#### 3.1. FACTORY IP ADDRESSES

The devices leave the factory with the following configuration:

ETHERNET "LAN" PORT      static IP: 192.168.90.101  
 ETHERNET "WAN" PORT    DHCP active  
 WI-FI                      Not active (where present)

#### 3.2. IP ADDRESS SEARCH

The devices leave the factory with the default IP address 192.168.90.101, on Ethernet (LAN),  
 If this address is changed or forgotten, it can be recovered using the "Seneca Device Discovery" software.

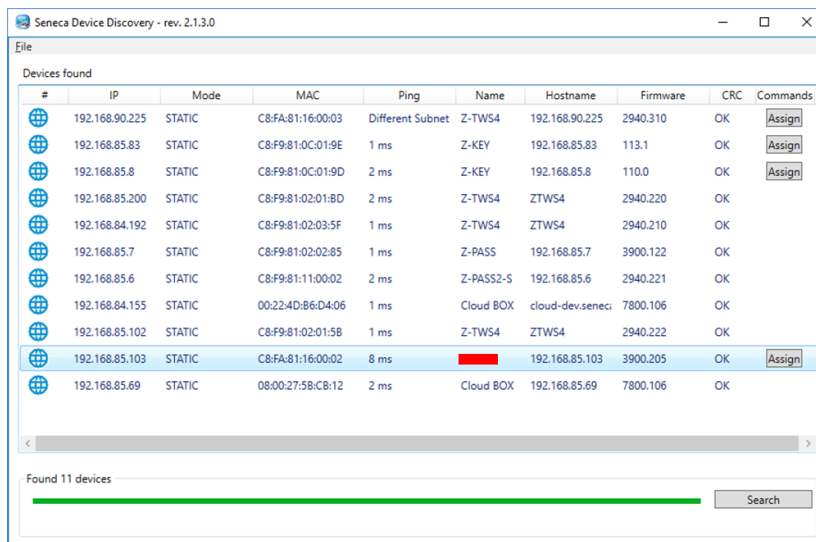

This application shows the IP address, MAC address, FW version and some other useful information, for each SENECA device connected to PC.

Moreover, by clicking on the "Assign" button, it is possible modify the device network parameters, as shown in the following figure:

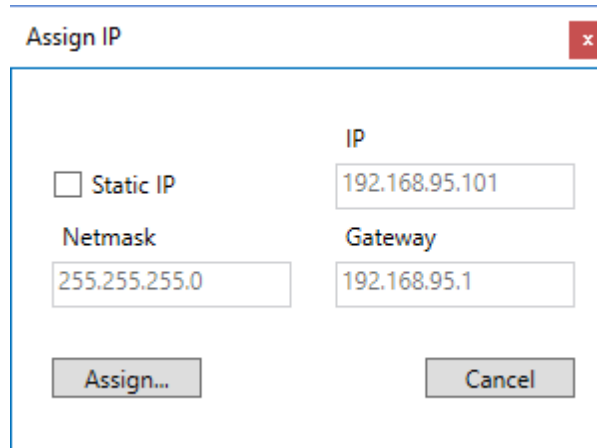

For security reasons, this function can be disabled, in this case, after clicking on the "Assign" button the following error message will be visualized

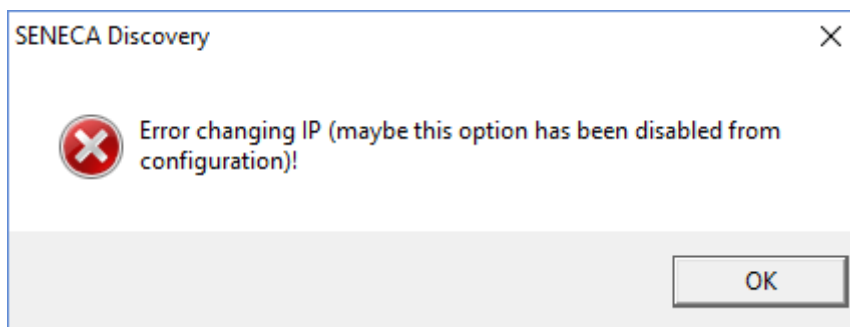

The software can be easily installed by running the installation program available at the following link:  
<http://www.seneca.it/products/sdd>

**NOTE:**

The IP address shown by the Seneca Discovery Device software is the IP address of the LAN peripheral when the PC is connected to the LAN port, the WAN IP address when the PC is connected to the WAN port and of the WI-FI if it is connected to the latter; moreover, all the changes of network configuration parameters are applied to the relative peripheral.

#### 4. ACCESS TO THE WEBSERVERS OF THE DEVICES

I IOT devices are equipped with two webserver:

- The webserver with the virtual display
- The configuration webserver

## 4.1. CONFIGURATION WEBSERVER ACCOUNT

In addition to the “ADMIN” account, there are also the “guest” and “operator” accounts:

### 4.1.1. CONFIGURATION WEBSERVER WITH “GUEST” ACCOUNT

You can access the configuration site of the device with the “guest” account; this account is not allowed to access all the pages but it is possible to view all the configuration parameters and the status information, without being able to modify them; therefore, in all the pages, the “APPLY” buttons (and any other button used to make changes) are disabled.

To log in with a "guest" account, connect your browser to the IP address of the device on port 8080, for example:  
`http://192.168.90.101:8080`

and, when required, provide the following credentials (default values):

Username: guest

Password: guest

### 4.1.2. CONFIGURATION WEBSERVER WITH “OPERATOR” ACCOUNT

You can access the device configuration site with “operator” account; this account can only configure IP addresses.

To access with “operator” account, connect to the browser to the IP address of the device on port 8080, for example:

`http://192.168.90.101:8080`

and, when required, provide the following credentials (default values):

Username: operator

Password: operator

## 4.2. FIRST ACCESS TO THE WEB SERVER

The devices are accessible by default from the “LAN” Ethernet port with the static IP address 192.168.90.101. The webservers are available via http and/or https (depending on the configuration). Both protocols are active by default.

On the http protocol the webserver with the virtual display is located on port 80 (default for browsers), so type:

***http://192.168.90.101***

while the https is:

***https://192.168.90.101***

Otherwise the web server on http protocol for configuration is located on port 8080, therefore:

***http://192.168.90.101:8080***

while for the https:

***https://192.168.90.101/maintenance***

Username: admin

Password: admin

### **4.3. WEBSERVER WITH VIRTUAL DISPLAY**

For more information on this Webserver, refer to the relevant chapter of this manual.

### **4.4. CONFIGURATION WEBSERVER**

For more information on this Webserver, refer to the relevant chapter of this manual.

## **5. DATA ACQUISITION AND PROCESSING, ALARMS GENERATION AND SENDING, DATA SENDING**

Edge IIOT devices allow you to acquire data from the embedded IOs of the devices or from the buses (via industrial communication protocols), this data is saved in a shared memory and can be processed via scaling or via logical rules or via the straton PLC. Once the data has been processed, it is possible to save it in an external storage device (USB or SD card) or send it to the clouds or FTP/Email servers etc.

The alarms are generated by the logical rules and can also be sent to the clouds or via Email/SMS.

Please refer to the following block diagram:

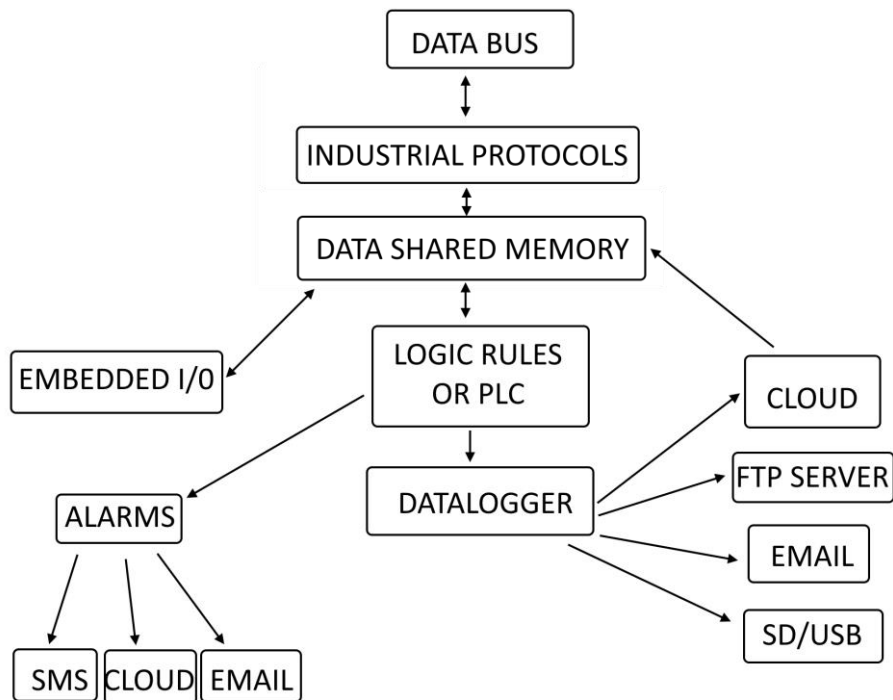

The acquisition of data (Tags) in the buses (Data Bus) takes place via industrial protocols (Industrial Protocols) or via direct acquisition of the integrated I/Os (Embedded I/O).

This data flows into the shared memory (Data Shared Memory), in this memory the logic rules or PLC perform the data processing (Logic Rules or PLC).

The data logger acquires the processed data and stores it via client protocols (on Cloud, FTP server, Email, SD card, Usb storage).

The logical rules or the PLC generate alarms that can be sent via EMAIL, Cloud or SMS.

The Cloud can access and then write the data already processed in the shared memory (Shared Memory).

Below we will analyse the main components of the block diagram.

### 5.1. THE DATA BUS AND INDUSTRIAL PROTOCOLS

Typically the data resides in external devices and must be connected via industrial protocols.

The device includes a series of industrial protocols so that it can connect with the most varied third-party manufacturers.

Among the most important protocols we mention the Modbus protocols and the OPC-UA protocol

### 5.1.1. MODBUS PROTOCOLS



Modbus was born as a serial communication protocol by Modicon (a company now part of the Schneider Electric group) to connect their programmable logic controllers (PLCs). It has become a de facto standard in industrial communication, and is currently one of the most widespread connection protocols in the world among industrial electronic devices. In addition to the serial version, Seneca devices also support the Ethernet-based version.

The supported Modbus protocols are:

- Modbus RTU Master protocol
- Modbus RTU Slave protocol
- Modbus TCP-IP Client protocol
- Modbus TCP-IP Server protocol

For further information, see website:

<https://modbus.org/>

Thanks to these protocols it is possible to acquire variables in the memory directly from external Modbus RTU slave or Modbus TCP-IP server devices.

### 5.1.2. OPC- UA PROTOCOL



OPC Unified Architecture (OPC-UA) is a standardized machine-to-machine communication protocol for industry 4.0 developed by the OPC Foundation.

OPC-UA is a vendor-independent communication protocol and is based on the client-server principle. Seneca devices support the OPC-UA server protocol also with security policy.

For further information, see website:

<https://opcfoundation.org/>

In particular, the OPC-UA server "exports" the internal memory tags then, using an OPC-UA client or other protocol it will be possible to read and write directly all tags.

## 5.2. SHARED MEMORY AND TAGS

The data acquired from the buses or I/O integrated into the devices flow into the shared memory, this memory is accessible from outside the device with various protocols (for example OPC-UA or Modbus TCP-IP or RTU). Each piece of data is identified by a mnemonic name and a type (integer, floating point etc.), thus characterized it takes the name of "Tag".

On these Tags it is possible to perform various types of processing as we will see later in the manual.

## 5.3. DATALOGGER

The Seneca IIOT Edge Gateways include a powerful data logger that allows you to manage up to 2000 variables at the same time (TAG). It is also possible to scale each variable and perform further processing with the PLC or with logical rules. The data acquired by the data logger can then be sent to the various clouds/FTP/EMAILS or to USB/SD memories.

For the function, when the gateway function is set to "Modbus Gateway with Shared Memory" in the device it is also possible to activate the "Data Logger" mode:

Tag values are periodically stored in files (called "log files"), which can then be transferred.

Tags can be associated with up to four groups of Data Loggers, which can have different sampling and transfer periods.

The following "transfer" methods are currently supported;

- copied to USB stick / SD Card
- transferred to an FTP server
- sent to one or more e-mail addresses, as an attachment
- Sent to a server via http post
- Sent to an MQTT broker

More than one of the above methods can also be enabled at the same time.

Log files are stored in flash memory, so if one of the transfer methods temporarily fails, it can be successfully transferred later.

For each group of data loggers, the "cache" is filled if at least one of the following cases is reached:

- 1000 log files
- 500000/(number of groups enabled) samples (i.e. number of lines of a single log file)

When the limit is reached, the cache is "rotated", i.e. the oldest files are overwritten by the new ones.







**5.6. ALARMS**

A complete set of parameters are available for TAG alarms, as indicated in the “Alarm Configuration” page of the webserver.

The entire alarm status can be viewed in the “Alarm Summary” page and the alarm history can be retrieved in the “Alarm History” page.

Moreover, in the "Tag View" page, the columns "ALARM" and "ANALOG DANGER ALARM" show the current alarm status for each tag.

Alarm generation is managed through logical rules or directly from the Straton PLC (optional).

**6. GRAPHICAL DISPLAY OF DATA ON THE DISPLAY / VIRTUAL DISPLAY**

The Seneca IIOT Edge Gateways include a powerful graphical interface, depending on the model there is a 7” touch physical display and/or a virtual display accessible via a web browser. Everything that can be done in the real display is also available in the virtual one, the finger touch is replaced by the pointer and the mouse button.

The display consists of 3 sections:



"A" Represents the bar with the device information

"B" Represents the Smart Display menu

"C" Represents the Widget page

### 6.1. INFORMATION BAR

Represents the information related to the device status , in particular:



- Icon "A" provides information about the device (such as firmware revision) and manufacturer
- Icon "B" provides user account information; in case you are not logged in, the icon is replaced by a padlock. The icon on the left, if pressed, allows to logout, the icon on the right indicates the type of user account (A stands for administrator). In the case of guest accounts the icon is shown as follows : 
- "C" icon shows the status of the serial port COM1
- Icon "D" shows the status of the serial port COM2
- Icon "E" shows the status of the VPN connection: "Seneca Let's VPN" or "OpenVPN standard".
- Icon "F" Provides the strength of the WI-FI signal (if present, depending on the model)
- "G" icon shows the status of the datalogger
- "H" shows the date/time of the device

### 6.2. MENU

Shows the menu:

HOME leads to the main page

SETUP leads to device configuration of the device

ALARMS leads to the alarms section

CHART leads to the section related to the graphic analysis of the datalogger data

It is also possible to hide the menu pressing the side bar:



## 6.2.1.SETUP

### 6.2.1.1. NETWORK

	NETWORK	PAGES	TAGs	DISPLAY	USERS	SERIAL
HOME	LAN	IP address Mask		192.168.90.103 255.255.255.0		
SETUP	WAN	DHCP IP address Mask		OFF 192.168.85.103 255.255.252.0		
ALARMS	WIFI	Mode		OFF		
CHART	DG & DNS	Gateway DNS AUTO DNS1 DNS2		192.168.85.1 OFF 192.168.84.113 0.0.0.0		

**SURPRISE** Smart Display ⓘ 15/04/2021 17:07

In this section it is possible to configure the settings for the LAN and WAN Ethernet ports and WI- FI network port.

The WI- WIFI port section allows to you choose WI-FI Station or Access Point mode.

The Station mode allows the device to connect to an existing Wi-Fi network, instead, the Access Point mode allows the device to create a new Wi-Fi network to which other devices can connect.

### 6.2.1.2. PAGES

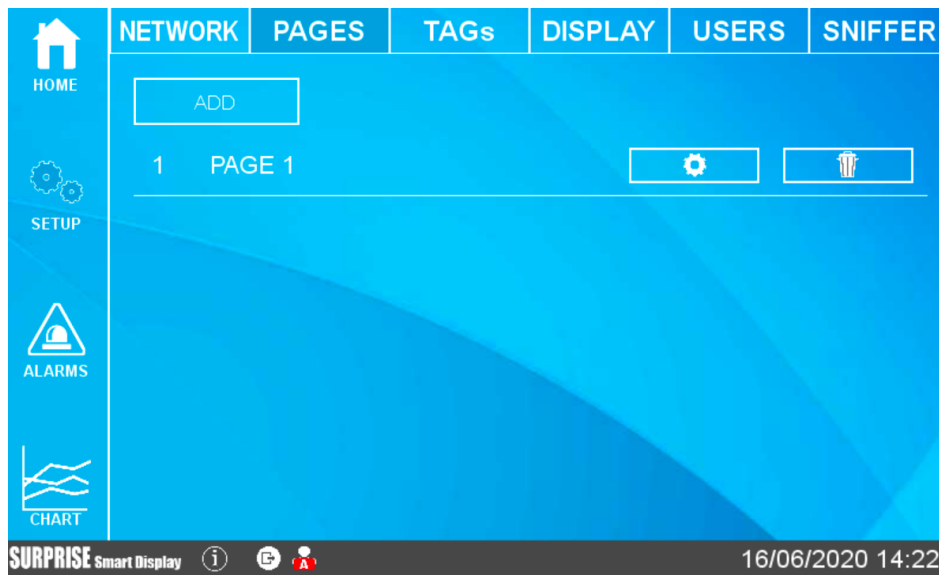

On the first screen it is possible to add as many pages as user desires and once pages are created, he is able to edit configuration of each one.

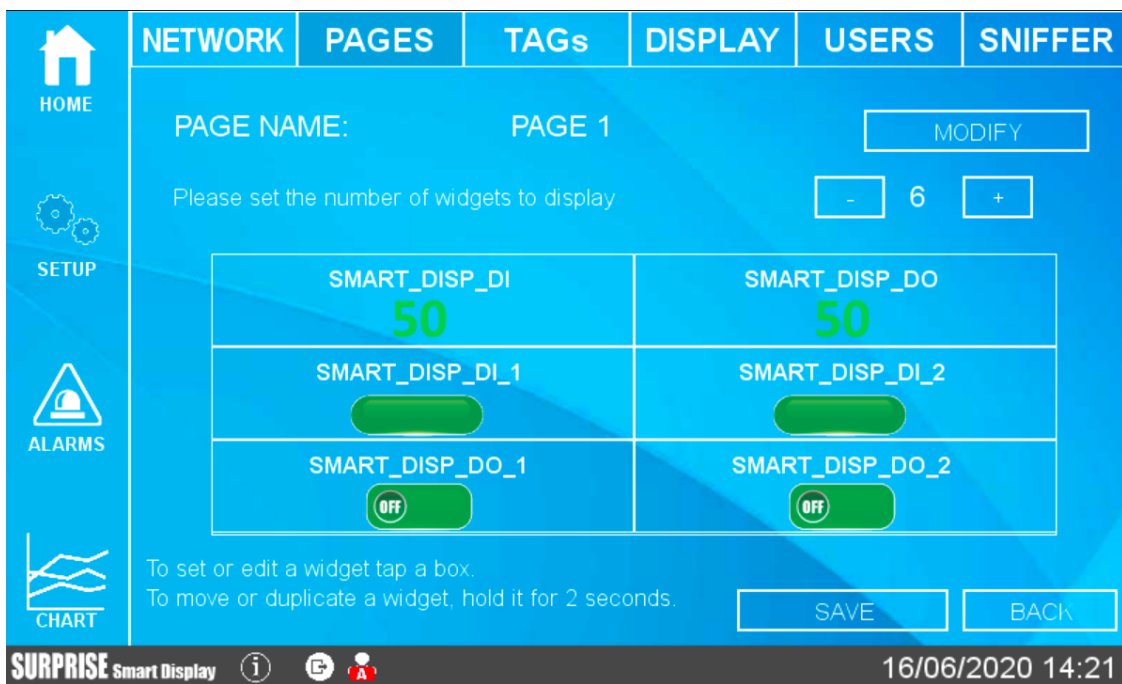

It is possible to change the page name and the number of widgets to show.

In the central part there is a preview of the page visualization.

Pressing on a widget icon it is possible to modify the widget parameters: type, colour, etc...

In addition to a widget page it is possible to add a Synoptic page. In a synoptic page it is possible to freely position the widgets and upload graphics from a PC or from a graphics library inside the device to create synoptic pages without the aid of external software.

**6.2.1.3. TAGS**



In this section the configured tags are visualized.

The device tags are located on the right side (A), it is possible browse the list.

The parameters of each tag appear in the central part (B), you can also scroll through the list.

From firmware version 109 it is possible to add, edit and delete tags also from the display.

**6.2.1.4. DISPLAY**

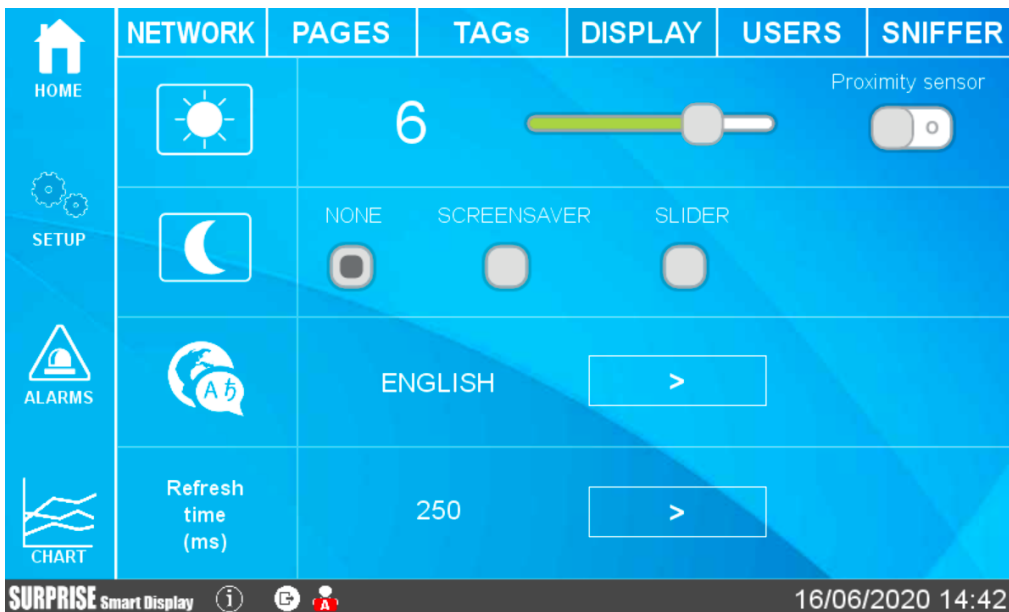

This section allows to configure the screen brightness, language and screen refresh time.

In order to safeguard the consumption and the duration of the screen, it is possible to activate the screensaver (the backlighting of the screen is lowered after the set idle time).

If the screensaver mode is enabled it is possible to exit by pressing anywhere on the screen (or making a movement in front of the screen if the proximity sensor is activated).

Slider mode, instead, allows to cycle the widget pages automatically after a preset time.

6.2.1.5. USERS

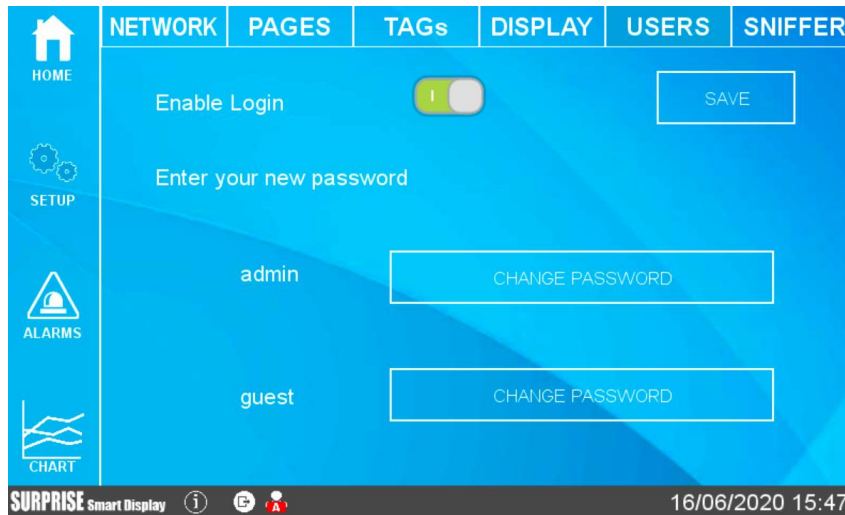

This section allows to configure the users who can access to the display.

It is possible to disable the login to access the display (free access) or activate an administrator account and/or guest account.

According to the following table

<b>ACCOUNT TYPE</b>	<b>CHANGING THE VALUE OF A TAG</b>	<b>SETUP MENU DISPLAY</b>	<b>SETUP MODIFICATION</b>
ADMIN	Yes	FULL	Yes
GUEST	Yes	ONLY "NETWORK" AND "TAGS"	NO
NO ACCOUNT	No	NO	NO

If the screen saver is switched off and none touch the screen for 2 minutes the system will automatically logout. If the screen saver is activated and none touch the screen for a time equal to the screen saver time, the system will automatically logout.



### 6.2.1.6. SERIAL

Permette di configurare i parametri delle seriali e definire se il protocollo Modbus deve essere Master o slave.



### 6.2.1.7. SNIFFER

The serial sniffer function allows you to insert one or more sniffer devices into an existing system with Modbus RTU protocol in an RS485 bus.

For Modbus RTU protocol there is always a single master and a series of slave devices. The master requires registers to read/write to each slave, who answers sending requested data.

In order to insert a device that displays data without changing the existing configuration, it is necessary to insert one or more devices in passive mode (sniffer).

At this point the devices will receive all the serial packets transmitted between the master and the slaves and it is necessary to associate these packets to tags that will be valued.

**ATTENTION!**

***As the SNIFFER mode is purely passive all defined tags will be read-only***



6.2.1.8. SNIFFER MODE CONFIGURATION STEPS



The sniffer mode is configured through the following steps (the three buttons at the top of the page):

1) BUS COMMUNICATION SCAN

In this learning mode the device will start to scan the flow of information passing through the bus. Typically, a Master interrogates all the devices in a continuous cycle, so when you are sure that the cycle has ended you can stop the scan. Attention: the operation to stop the scan is always manual. BUS COMMUNICATION SCAN

2) TAG CREATION

In this phase the device has identified the registers that the devices are exchanging, now it is necessary to associate the name of the tag and the type of data it contains. In the case of a system with Seneca products, it will be necessary to introduce the type of Seneca device and the system will automatically associate the correct tags, in the case of third party devices, the information relating to each register identified will be requested.

6.2.2. ALARMS

ALARMS			HISTORICAL ALARMS		
NAME	TAG	STATUS	TIME ON	ACTION	ACT TIME
ALR_DO_1	SMART_DISP_DO_1	Alarm	16/5/2020 16:53:21	None	
ALR_DO_2	SMART_DISP_DO_2	Alarm	16/5/2020 16:53:27	None	

CONFIRM

**SURPRISE** Smart Display 16/06/2020 16:56

This section shows the active alarms and alarm history.

If the alarm requires manual acknowledgement, it is possible to use the appropriate button:

ALARMS			HISTORICAL ALARMS		
NAME	TAG	STATUS	TIME ON	ACTION	ACT TIME
ALR_DO_1	SMART_DISP_DO_1	Alarm	16/5/2020 16:53:21	Acknowledge	16/5/2020 17:0:16
ALR_DO_2	SMART_DISP_DO_2	Alarm	16/5/2020 16:53:27	None	

CONFIRM

**SURPRISE** Smart Display 16/06/2020 17:01

In the Historical section are represented all the alarms that have occurred so far:

HOME	ALARMS			HISTORICAL ALARMS		
	NAME	TAG	VALUE	LEVEL	STATUS	TIME
SETUP	ALR_DO_1	SMART_D ISP_DO_1	1	Alarm	Acknowledge	16/5/2020 17:0:16
	ALR_DO_1	SMART_D ISP_DO_1	1	Alarm	Acknowledge	16/5/2020 16:58:51
	ALR_DO_2	SMART_D ISP_DO_2	1	Alarm	Alarm	16/5/2020 16:53:27
	ALR_DO_1	SMART_D ISP_DO_1	1	Alarm	Alarm	16/5/2020 16:53:21
ALARMS	<input type="button" value="CLEAN"/>					
CHART						
<b>SURPRISE Smart Display</b>   						16/06/2020 17:04

**ATTENTION!**

**ALARMS ARE CONFIGURED IN THE APPROPRIATE SECTION OF THE WEBSERVER**

**6.2.3.BUS**

This section allows external devices to be added via serial and/or Ethernet and their tags to be inserted:

HOME	DISPLAY	USERS	SERIAL	SNIFFER	BUS	MAINT.
	SETUP	DEVICE TYPE FILTER <input type="button" value="&gt;"/> ALL <input type="button" value="ADD DEVICE"/>				
ALARMS						
CHART						
<b>SURPRISE Smart Display</b> 						15/04/2021 17:13

The device uses a database that includes records of all Seneca devices.

Adding a device can be done in manual mode (by entering the device among those in the database or from a manufacturer other than Seneca) or by automatically searching for the device on serial or Ethernet. The automatic search also automatically creates tags but only works with Seneca devices.

#### 6.2.4. MAINTENANCE

The Maintenance menu allows maintenance operations to be carried out on the device:

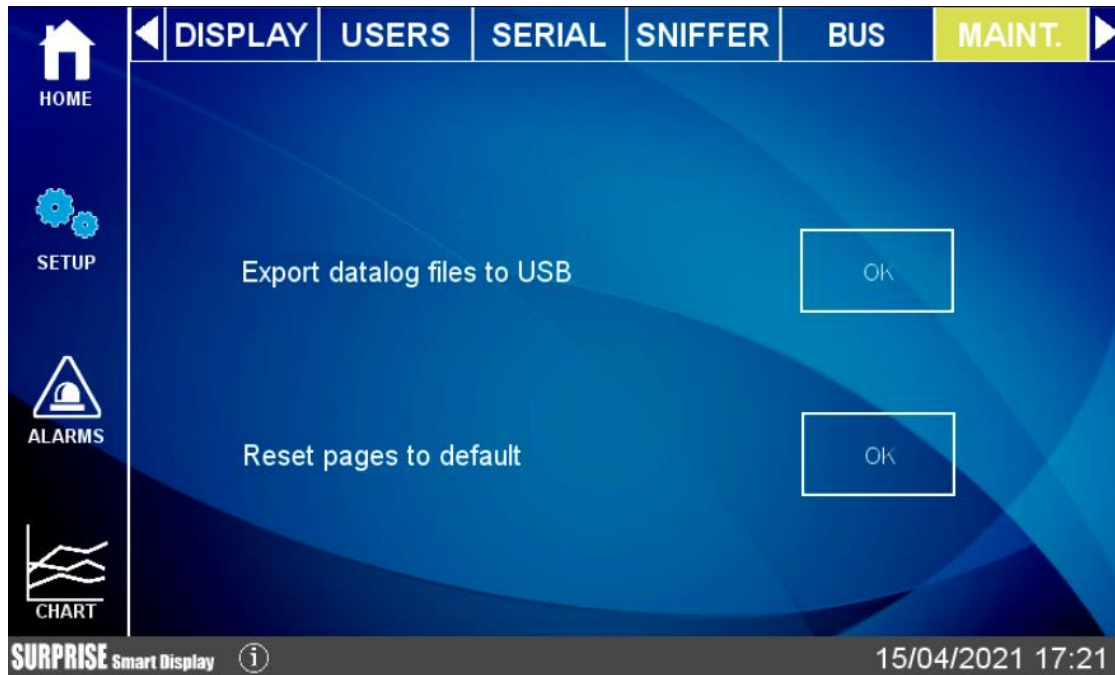

**6.2.5. CHART**

There are 3 types of graph available: Real Time, Historical and Histogram.

In the Chart Real Time section the tag values are displayed in real time (maximum 10 tags):

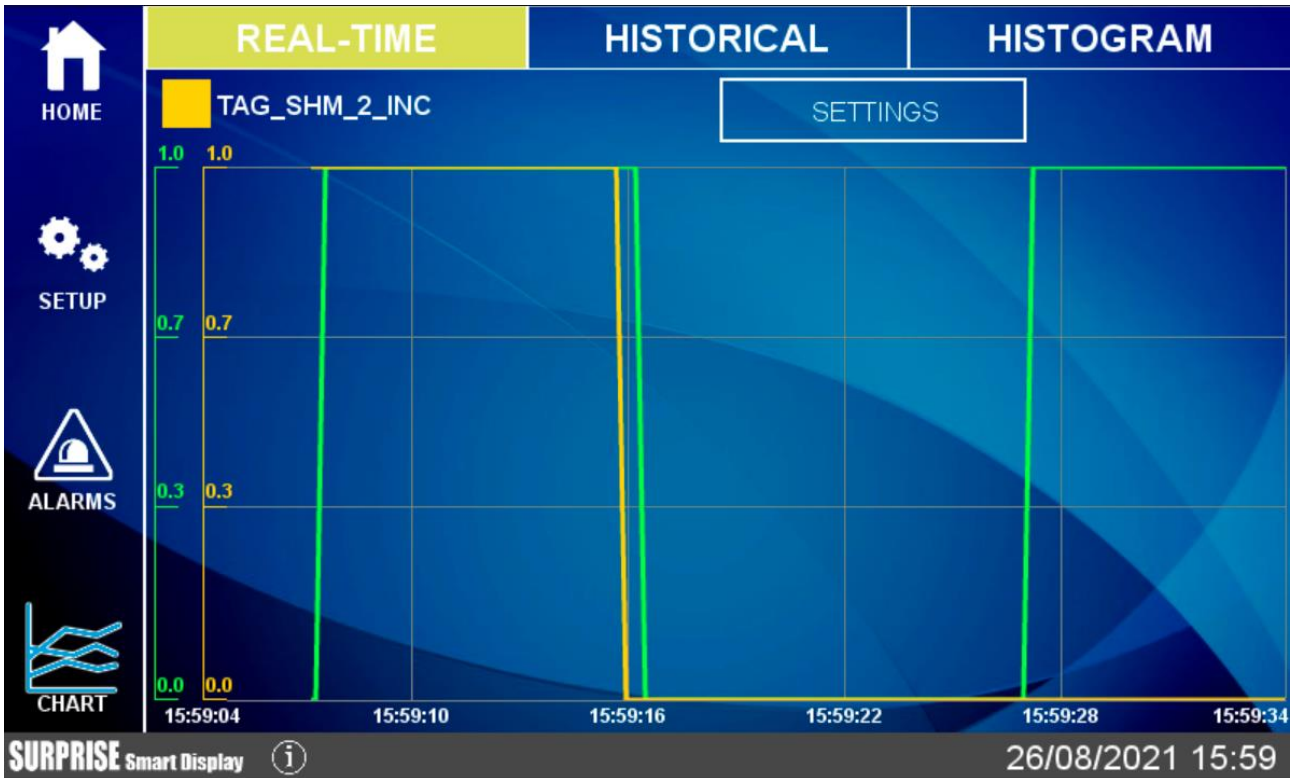

The configuration of the real time graph will be recalled also from the relative widget.

In the Historical section, on the other hand, you can load data in the desired range and move back and forth in the graph, using the touch screen.

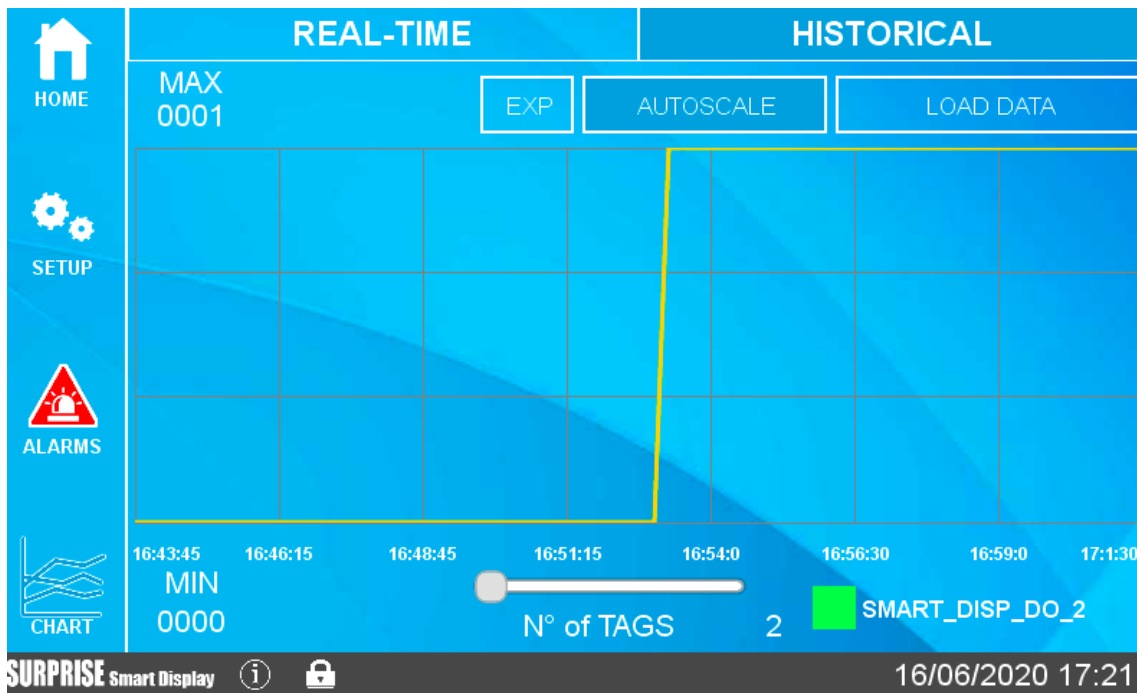

In case a USB disk is connected, it is possible to export to a file the chart values displayed, by pressing the "EXP" button.

If user is connected via web to the remote display, pressing the "EXP" button the browser will download the file directly to the PC.





The Histogram chart is essentially the same as the Historical chart but with a histogram representation.

### 6.3. TYPE OF WIDGETS

Widgets are graphic elements that can be linked to one or more TAGs.

These can be used in both widget pages and synoptic pages.

There are various widgets available, here are some examples:

	<p><b>Text widget</b></p> <p>The TAG value will be displayed as text</p>
	<p><b>Gauge widget</b></p> <p>The TAG value will be displayed with a gauge indicator</p>
	<p><b>LED widget</b></p> <p>OFF/ON statuses will be displayed with colors</p>
	<p><b>LED BIT widget</b></p> <p>OFF/ON bit-mask statuses will be displayed with colors</p>



	<p><b>Button command widget</b></p> <p>When the button is pressed, the TAG will be set to the preset value</p>
	<p><b>Graphic Widget</b></p> <p>The TAG value will be displayed on a dynamic graph</p>
	<p><b>Vertical Bar widget</b></p> <p>The TAG value will be displayed on a dynamic vertical bar</p>
	<p><b>Horizontal Bar widget</b></p> <p>The TAG value will be displayed on a dynamic horizontal bar</p>

	<p><b>IMAGE widget</b></p> <p>Static image</p>
	<p><b>MULTI IMAGE widget</b></p> <p>Tag values will be displayed with different images</p>
	<p><b>Label widget</b></p> <p>Static label</p>
	<p><b>Multi Label widget</b></p> <p>Tag values will be displayed with different labels</p>



Widget macro graph (virtual display):



This is a virtual display, scroll through the pages of the virtual display by pressing the ">" arrow at the bottom right.

It is possible to place up to 2 virtual displays for each widget page.

### 6.3.1. PAGE CHANGE

To scroll from a page to the next, simply slide the finger to the left (this operation is called "swipe") as along the pages of a book;

similarly, to return to the previous page, simply slide the finger to the right.

To change the page it is also possible to press a "forward" arrow and a "back" arrow:

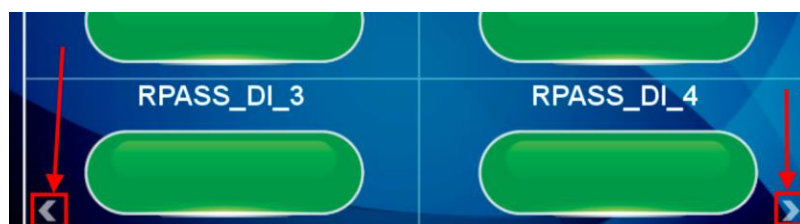

### 6.4. TYPE OF WIDGET PAGE

It represents the widgets page, in this section the widgets linked to the configured tags will appear. You can choose from the various grids available, the widgets will be automatically positioned within the grid.

Each widget graphically represents the value of one or more TAGs.

### 6.5. SYNOPTIC PAGE TYPE

In a synoptic type page it is possible to freely move the widgets by adding graphics and also create animated synoptic ones.

Synoptic type pages can be freely mixed with widget type pages.

To create a synoptic page Select Pages and press the "Add Synoptic Page" button.  
At this point a new page will open with tools on the left:

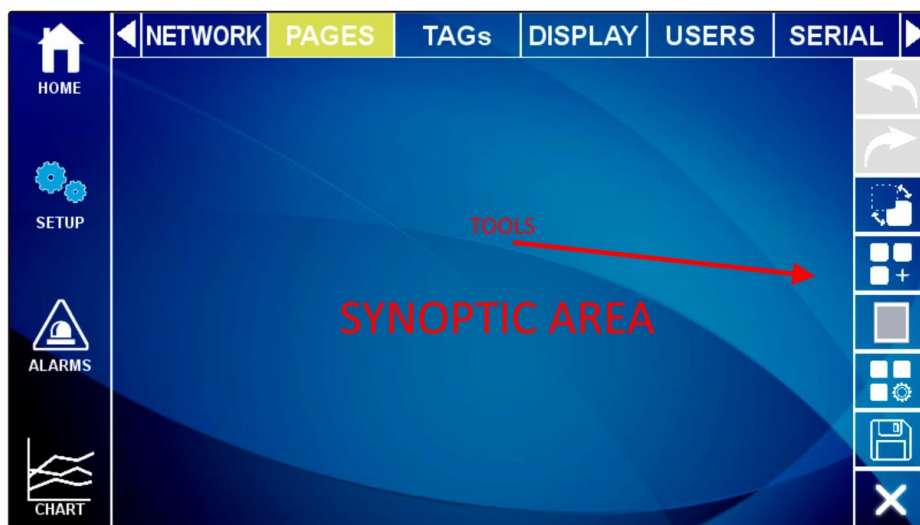

Here is the meaning of the tool icons:



UNDO

Cancels the last operation performed



REDO

Repeats the last operation cancelled by the UNDO



BACKGROUND

Allows you to choose a graphic file to use as the background of the page



ADD WIDGET

Adds a widget to the page



ADD VIRTUAL DISPLAY WIDGET

Adds a virtual display widget



WIDGET CONFIGURATOR

Allows the widget configuration



SAVE PAGE

Saves the page changes



EXIT

Exits the page

### 6.5.1. "ADD WIDGET" TOOL



The "ADD WIDGET" button allows the addition of a widget on the page, once the widget has been inserted it is possible to move it by touching the widget in the central cross. To change the size of the widget, move the sides of the rectangle containing the widget:

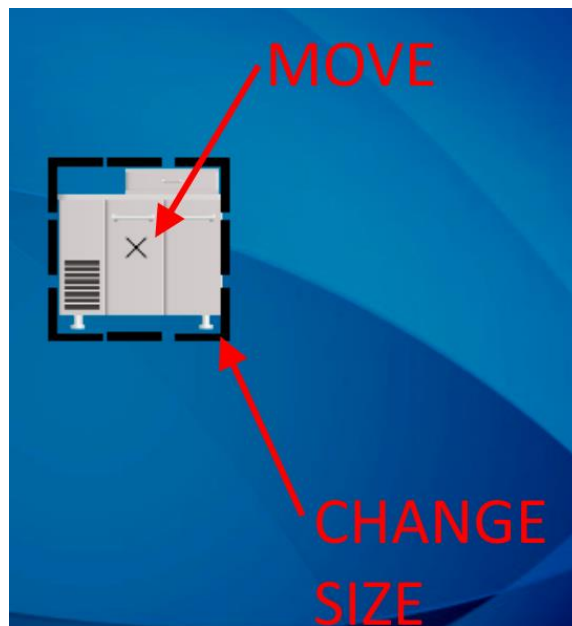

When a widget is selected, a new series of tools appears on the right, the meaning of which is as follows:



A grid is activated, moving the widgets they will follow the set grid.



The widget is aligned



Modification of the configuration parameters of the selected widget is allowed and viewed



The Widget is removed from the page



You return to the initial page of the synoptic

**6.5.2. DATABASE OF SYMBOLS FOR THE SYNOPTIC PAGES**

Inside the device is a database of graphic symbols that can be used in widgets. The symbols are divided into categories. To access the symbols, select, for example, the "Image" widget:

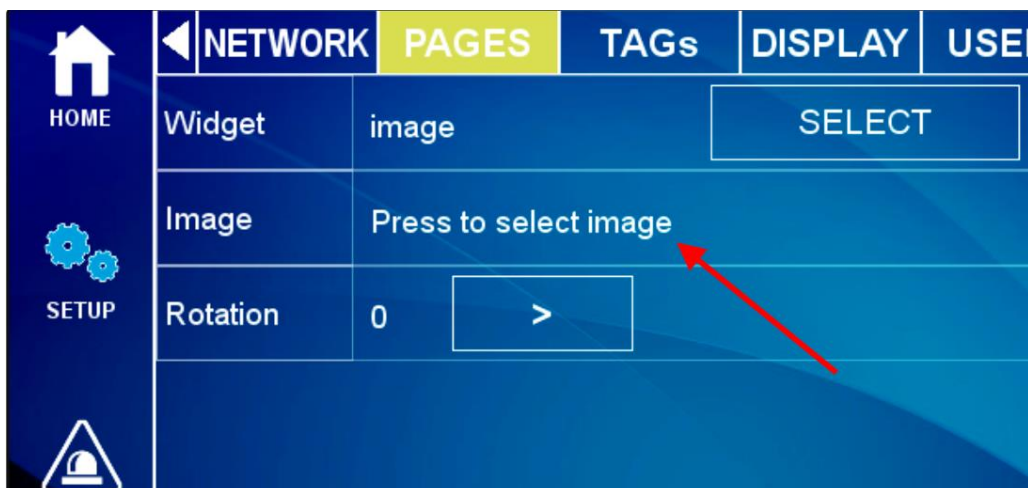

For example, selecting the "Motors" category displays the graphic files relating to engines:

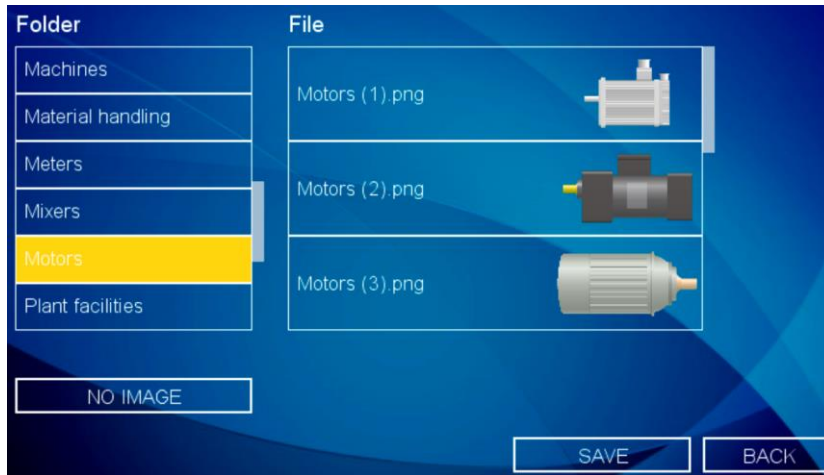

## 6.6. ALARMS

When an alarm occurs on at least one TAG, the title of the page is outlined in red and the faulty tags display the alarm icon, see the figure:

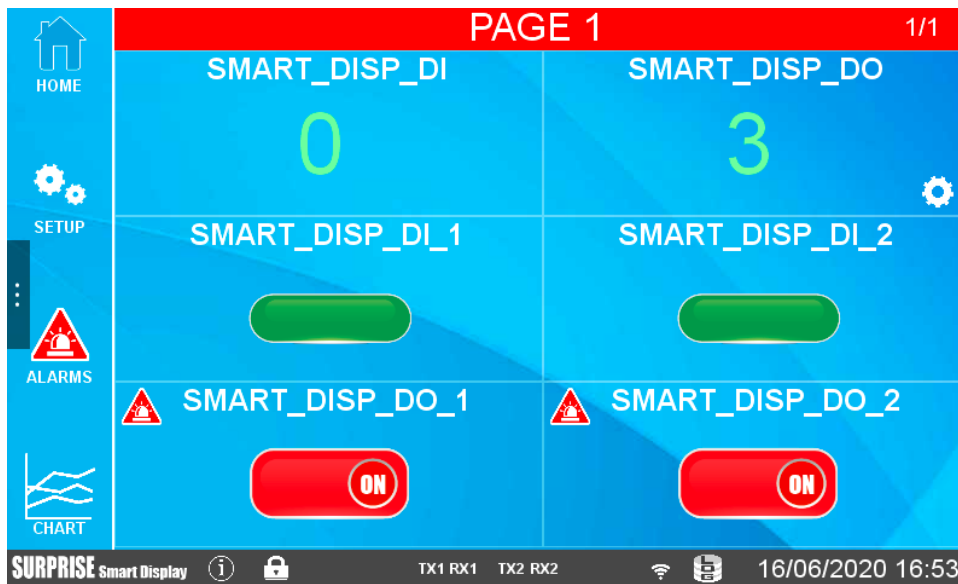

### 6.7. VIRTUAL DISPLAY

All the operations that can be done on the physical display can also be done connecting to the device web page via a web browser via port 80 (default).

To connect to the virtual display, enter the device's IP address into a browser on a PC or smart device:

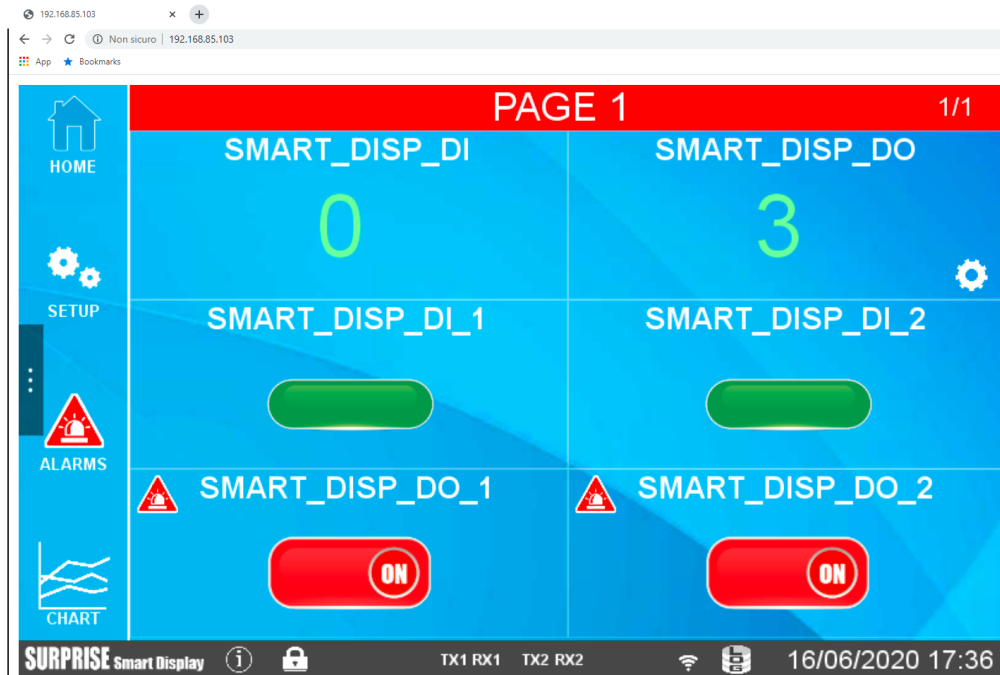

### 6.8. DOWNLOADING LOG FILES TO USB FLASH DRIVE

By inserting a USB stick in the HOST port it is possible to carry out a complete download of the files acquired by the datalogger.

To carry out this operation it is necessary to reach the "Maintenance" menu by tapping "SETUP" and then the arrow that extends the menu:

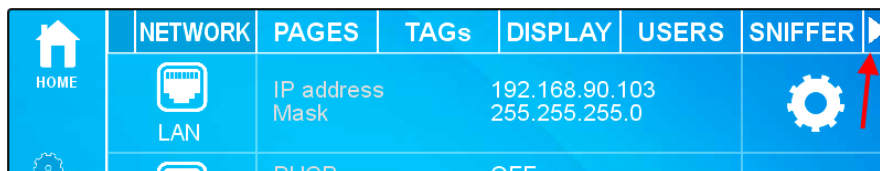

Now select "MAINT." and then press the relevant button to perform the operation:

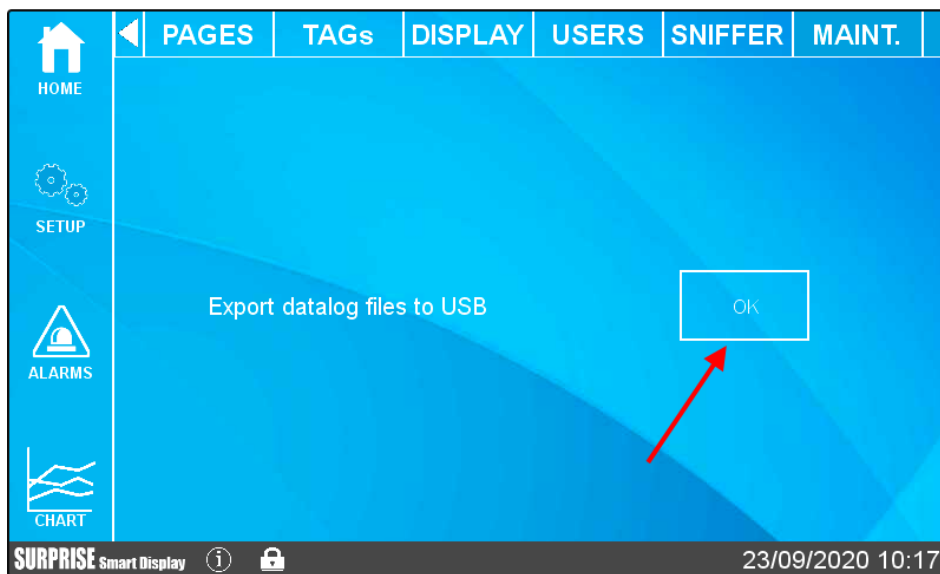

At this point the system will download all the files acquired by the datalogger. In the root of the USB stick there will then be many folders (one per day of recording) with the files related to that day (divided in turn into folders representing the active log groups). This functionality is also active via Webserver in the "TAG VIEW" section.

## 7. INDUSTRIAL GATEWAY / ROUTER / FIREWALL

The devices allow you to set the firewall, port mapping and other advanced features such as 1:1 NAT. In addition to these features, you can also activate the industrial gateway function.

### 7.1. SERIAL ETHERNET GATEWAY

You can activate the available protocols to create gateways for industrial protocols (for example from/to Modbus RTU to/from Modbus TCP-IP). Or you can activate the transparent mode.

### 7.2. MODBUS ETHERNET TO SERIAL GATEWAY

The device can be configured to operate as a Gateway from Modbus Ethernet to Modbus Serial. In this working mode, Modbus TCP Requests received from Ethernet interfaces are converted into Modbus RTU requests and sent to the serial interface; in the same way, Modbus RTU replies received from the serial interface are converted into Modbus TCP replies and sent back to the source network interface.

A Modbus Ethernet to Serial Gateway request can be activated for each of the available serial ports. In this mode Modbus Gateway can support up to 50 simultaneous Modbus TCP connections. These connections can also be established through a VPN tunnel.

### 7.3. TRANSPARENT ETHERNET TO SERIAL GATEWAY

As an alternative to Modbus Ethernet to Serial Gateway, the device can be configured to operate as a "Transparent Gateway". The big difference between these two working modes is that while Ethernet to Serial works only with the Modbus protocol, Transparent Gateway can be applied to extend (transport) any serial communication (regardless of RS232/RS85 protocol) through the TCP/IP stack.

You can choose the following transparent gateway modes:

- Virtual COM (with RFC 2217 support)
- Point-to-point serial tunnel on TCP
- Point-to-point serial tunnel on UDP

Each mode will be fully described in the following paragraphs.

#### 7.3.1. VIRTUAL COM WITH RFC 2217 SUPPORT

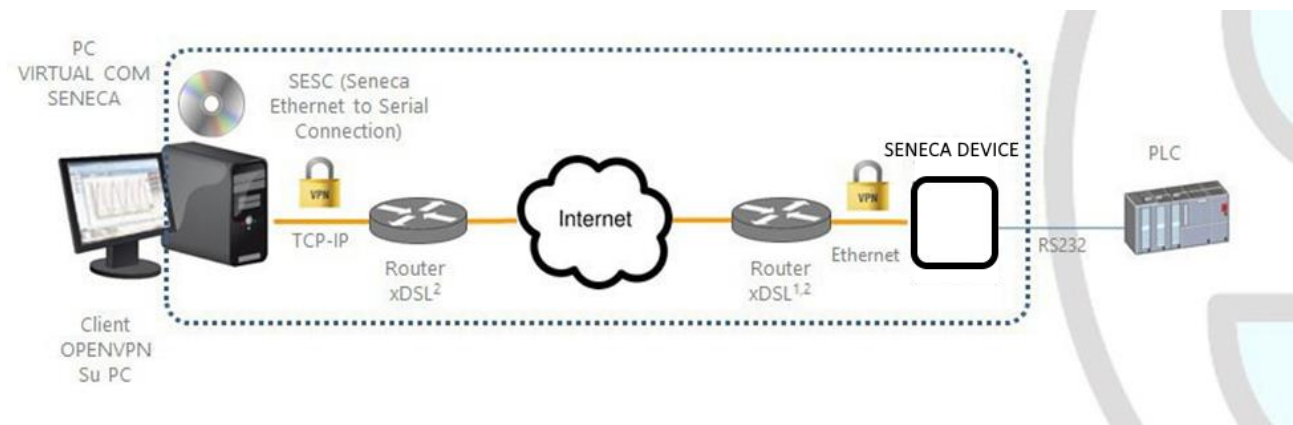

The Virtual COM with RFC 2217 support feature allows a PC application, which transmits data only on a serial line, to communicate with a remote serial device, using Ethernet/Internet; in other words, through the Seneca device, a PC and a serial device, located in distant sites, can communicate because they are directly connected.

In this mode, data sent over the LAN or WAN are received by the Seneca device and sent to the serial port; the response packets follow the reverse path.

The RFC 2217 support defines some features that allow the PC to set the properties (baud rate, data bits, stop bits and parity) of the serial port of the Seneca device remotely; so, when Virtual COM operating mode is selected for a port, the port is reconfigured independently from the previous settings and the values configured in the Seneca device are overwritten.

For the Virtual COM to work, a utility called "Seneca Ethernet to Serial Connection" must be installed on the PC. The TCP connection can be established through a VPN tunnel, as shown above.



Once the connection is established, a program using the virtual COM port will transmit the data to the serial port of the device; for example, Modbus RTU requests sent by a Modbus Master program will reach the Modbus slave devices connected to the RS485 bus of COM2.

Particular attention must be paid to the "Data Packing Interval" parameter, which can be set when the Virtual COM operating mode is selected: this parameter allows you to define the time interval, in milliseconds, used by the Seneca device as a criterion for packing the bytes of data received from the serial port before sending them to the network; in other words, when the Seneca device does not receive any more bytes from the serial port for the given time interval, it packs the received bytes and sends them over the established TCP connection; the optimal value to set for this parameter depends on the protocol that is transparently routed from the TCP/IP network to the serial line and vice versa.

**ATTENTION!**

***In Virtual COM operating mode only one serial port can be used***

**7.3.1.1. SENECA ETHERNET TO SERIAL CONNECT**

**7.3.1.1.1. INSTALLING THE SENECA SERIAL TO ETHERNET DRIVER**

Seneca Ethernet to Serial Connect is compatible with 64 bit Windows systems.

Double-click on the installer

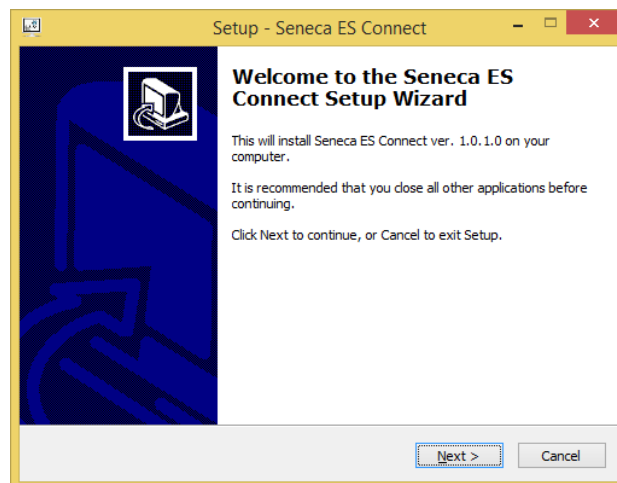

Then the com0com driver will be installed:

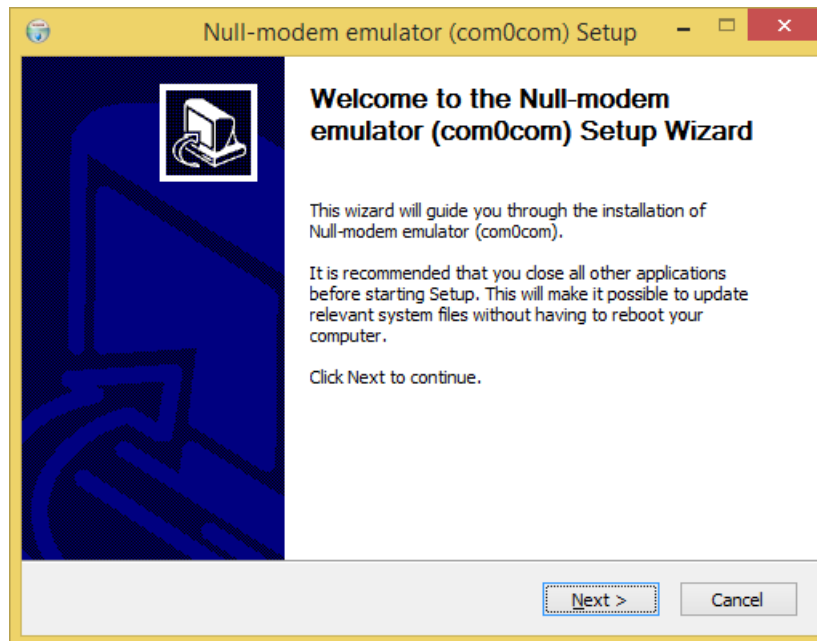

Select the virtual port names CNCA0<->CNCB0 and COM#<->COM#:

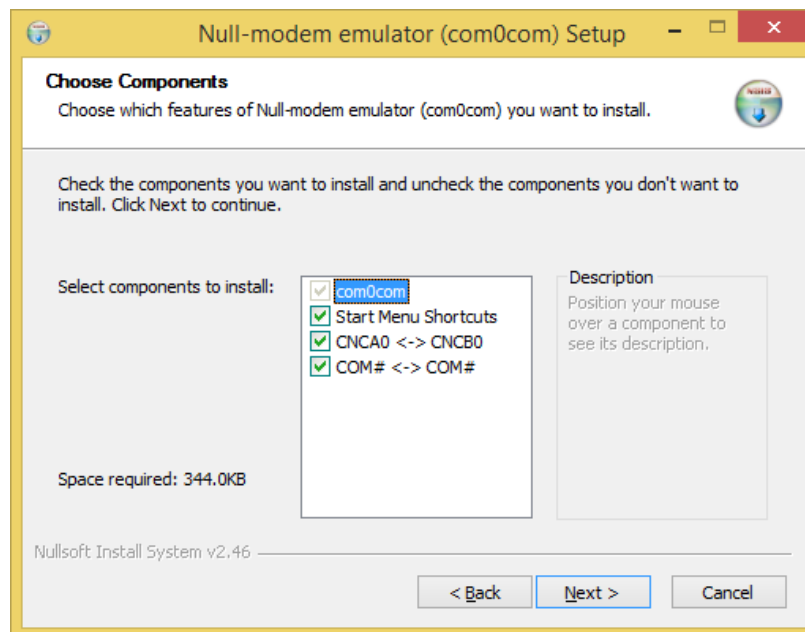

Now click on "Start Setup":

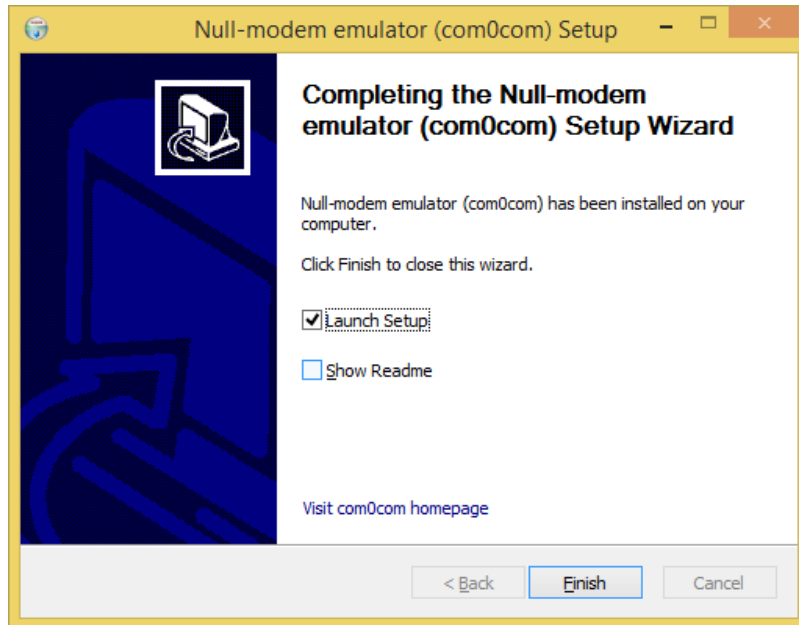

Press Finish, the com0com setup will open:

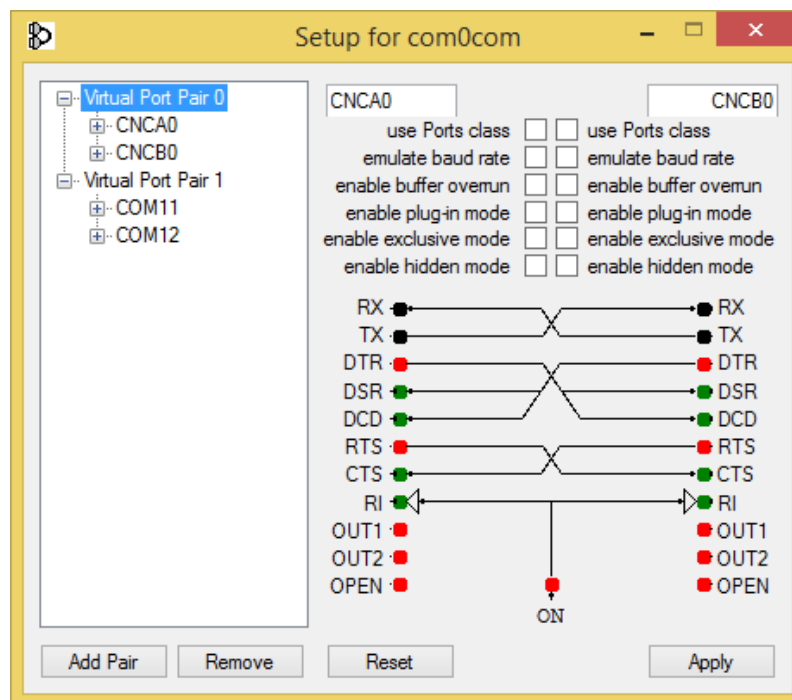

During installation two pairs of virtual COM are created:

CNCA0, CNCB0

and also:

COM11, COM12 (note that com# may be different in your system).

The first pair can be used in software that supports CNCA names, the other in software that only supports Port Classes.

If you need to add more virtual ports, press the "Add Pair" button, then select whether or not you need a Class port.

Confirm the driver installation with "Apply".

The pair of serial port emulators COM11-COM12 will be available in Device Manger

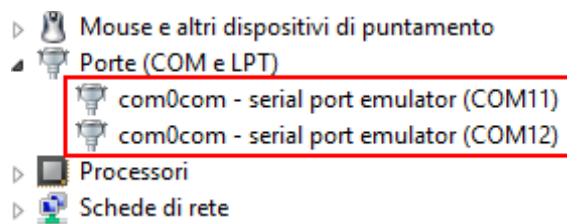

**7.3.1.1.2. COM PORT SELECTION FOR SENECA ETHERNET TO SERIAL TO CONNECT**

The driver installation will use the first 2 serial ports that are free (in our case the driver has created the pair COM4 and COM5):

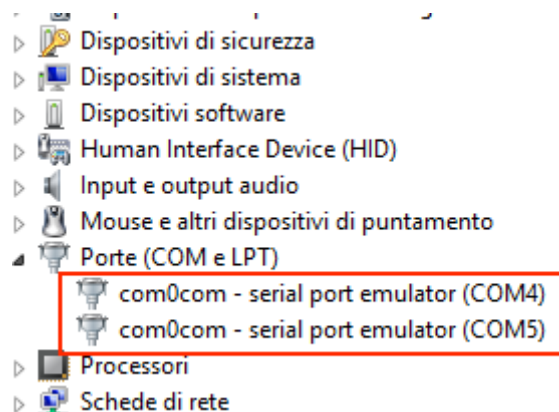

The software will use only one port (the correct port in the com0com setup), only com0com ports will be displayed.

Select COM5 in the Seneca ES connector:

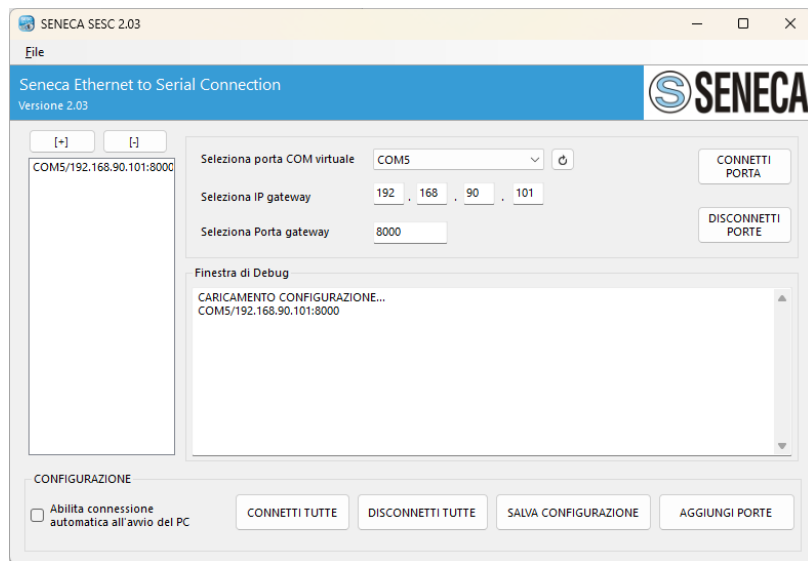

Now use the same COM port on application to use (e.g. in the terminal software)

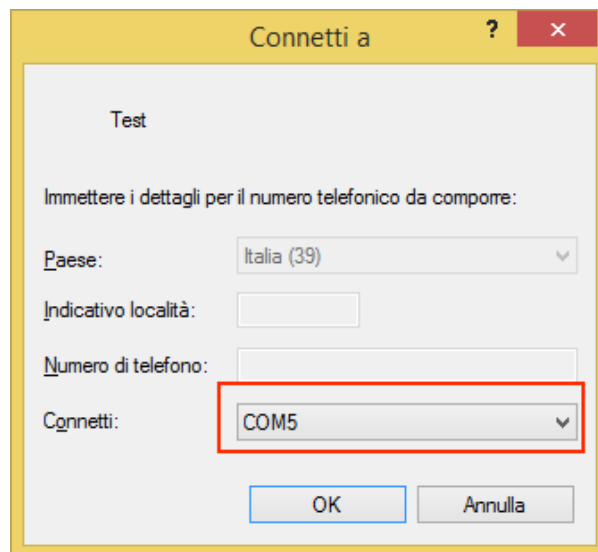

COM5 is now connected to the Seneca device by a TCP connection to port 8000.

### 7.3.1.1.3. SENECA SERIAL TO ETHERNET CONFIGURATION

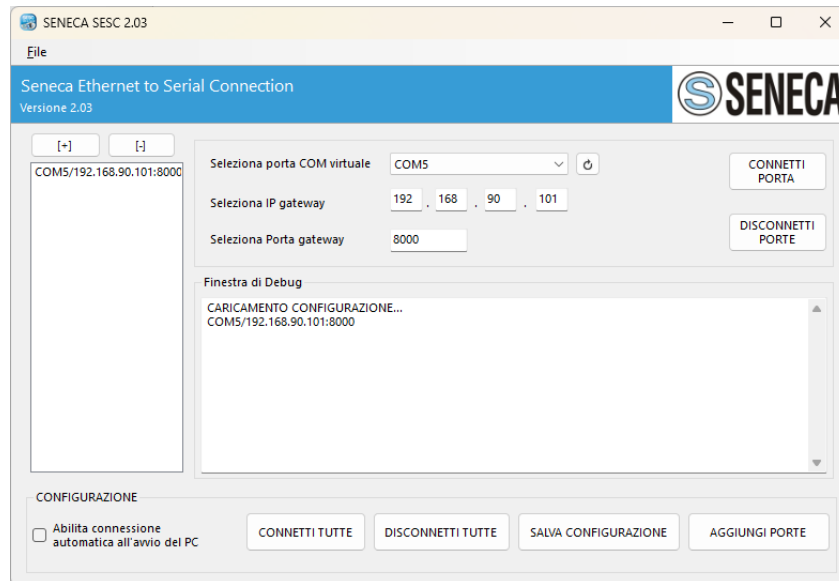

- Select the virtual COM port
- Select the IP address of the Seneca device
- Select TCP-IP port

Click on "CONNECT PORT".

If you need to connect another serial com to another Seneca device, just press the "ADD PORT" button and then the [+] button to configure the new com port and, selecting it, enter the new IP address, then always press the "CONNECT PORT" button.

To disconnect all ports, click on "DISCONNECT PORTS"

### 7.3.1.1.4. CHANGING THE PORT NUMBER

Older software applications can only use a small range of COM ports, so you may need to change the virtual COM port number.

In our case the COM pair created is COM4/COM5, let's see the procedure to change it to COM2/COM3

Click on DEVICE MANAGER - File menu

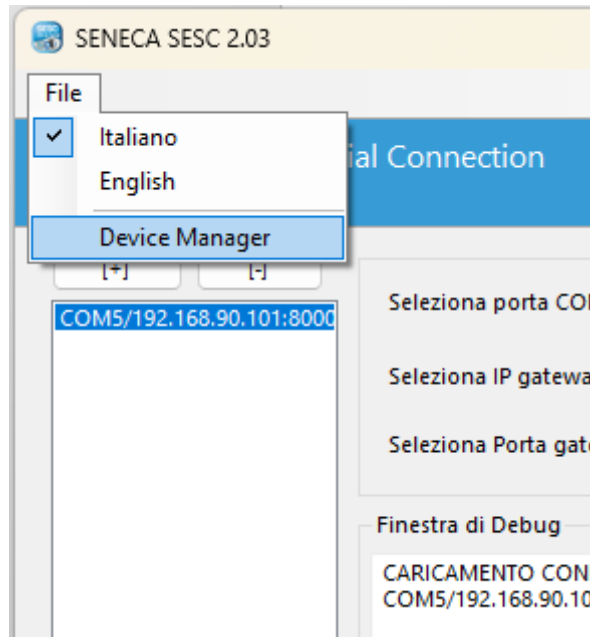

The com0com configuration window appears:

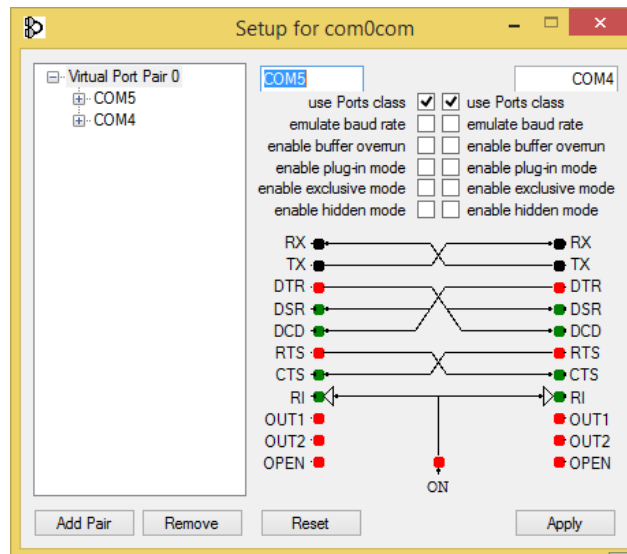

Now change COM5 to COM3 and COM4 to COM2, then click on "Apply":

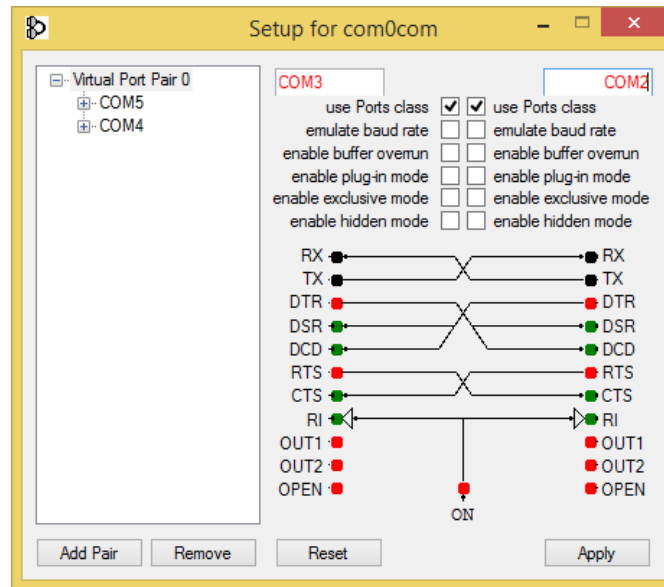

Sometimes the COM may be marked "in use":

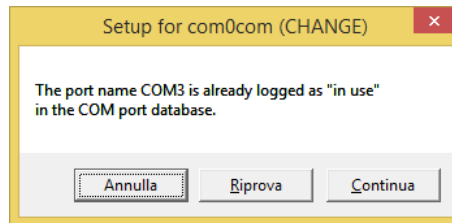

If you need to use this COM number, click "Continue", then go to device configuration.

Since the port is not connected, click on "Show hidden devices":

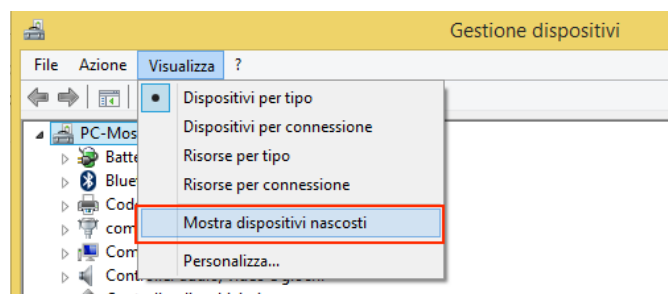



Now all unused ports are displayed in transparency (even our COM3):

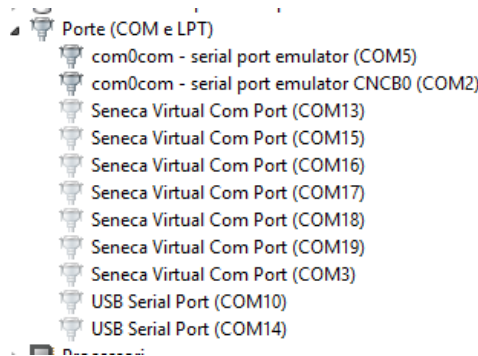

Now select the COM3 port and click on "Uninstall":

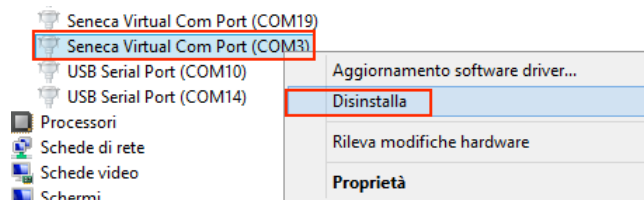

Now COM3 is free, and we can use it on the com0com setup:

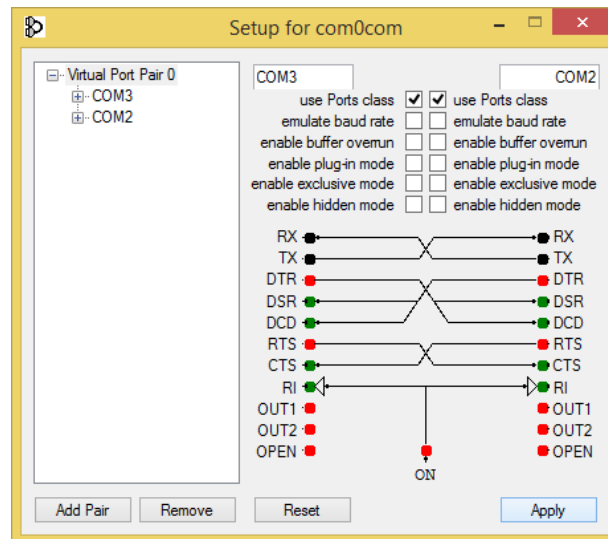

Finally click on "Apply", now the pair COM3/COM2 is created:

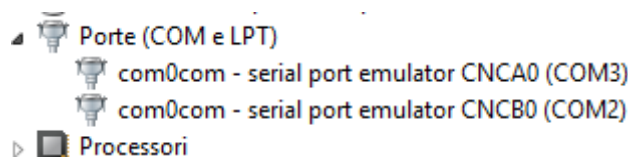

**ATTENTION!**

*The Seneca Ethernet to Serial Connect Software always uses the correct port of the pair created in the com0com configuration (in our case COM2).*

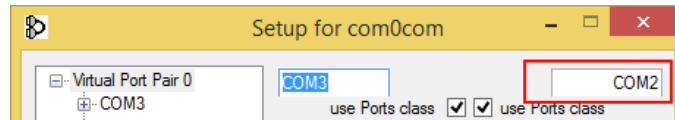

**7.3.1.1.5. AUTOMATIC CONNECTION AT PC STARTUP**

Once you have configured the necessary ports, you can automatically start the software at PC startup so that the connections are always active.

To do this, save the configuration with the appropriate button and check the enabling of automatic connection at PC startup:

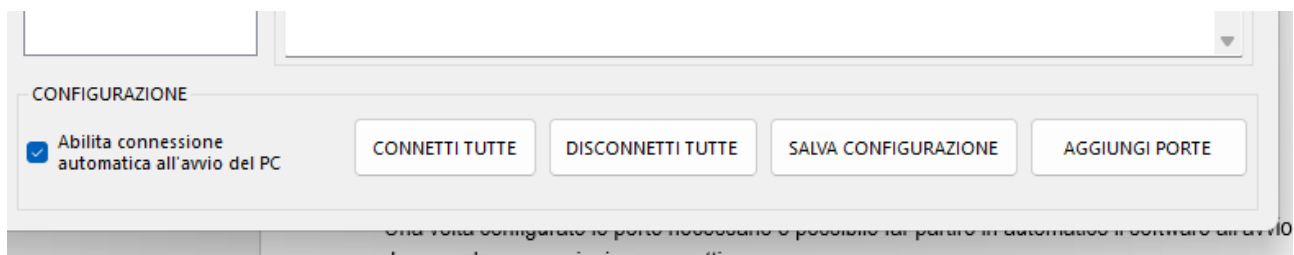

**7.3.2. SERIAL TUNNEL POINT ON TCP**

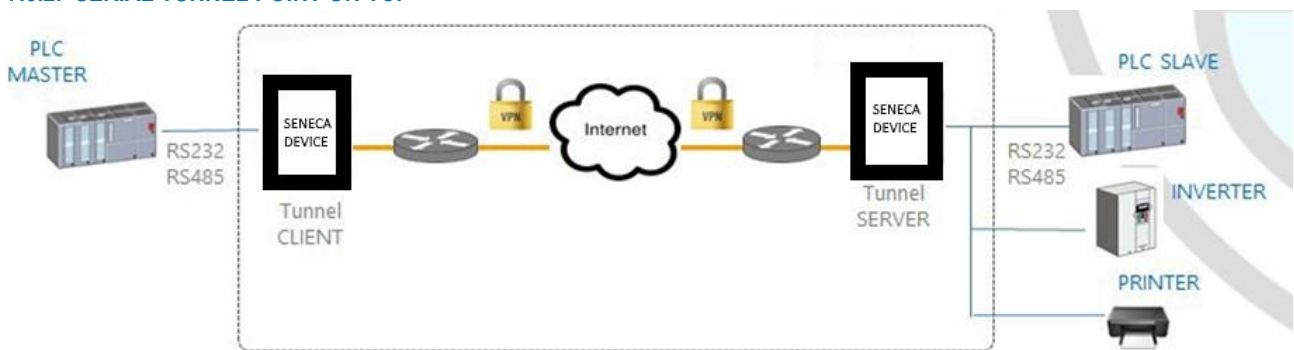

The point-to-point serial tunnel allows to extend a serial connection between two serial devices (that support the same protocol) via a TCP/UDP connection.

In TCP operating mode, one of the two Seneca devices is defined as "Master" and the other is the "Slave": the first is a Tunnel Client, which receives data from the serial line and sends them to an outgoing TCP connection,

while the second is a Tunnel Server, which receives data from an incoming TCP connection and sends them to the serial line; in this mode a "tunnel" is established between the two serial ports.

During configuration, on the Master, you must set the destination IP address and the destination Port that defines the outgoing TCP connection; on the Slave, you must set the Listening Port on which the incoming TCP connection is accepted.

The tunnel can also be established through a VPN connection..

### **ATTENTION!**

***In Serial Tunnel Point-to-Point the operating mode on TCP, only one connection is accepted for a given serial port.***

#### **7.3.3. POINT--TO-POINT SERIAL TUNNEL ON UDP**

The Serial Tunnel Point-to-Point operating mode on UDP is very similar to that of TCP.

The only difference is that none TCP connection is established and the serial data is carried by a UDP packet. The configuration parameters are the same as for the serial tunnel over TCP.

Again, The UDP packet can also passes through a VPN connection

### **CAUTION**

***In Serial Tunnel Point-to-Point operating mode on UDP, only one connection is accepted for a given serial port.***

#### **7.4. MODBUS GATEWAY WITH SHARED MEMORY**

The device can be configured to work as a Modbus Gateway with Shared Memory: in this mode, a set of configured tags are periodically and continuously read by Modbus RTU Slave or Modbus TCP Server devices; these values are copied and made available in a shared memory.

This mode supports up to 2000 tags and accepts up to 50 Modbus TCP Clients simultaneously, one Modbus TCP/IP Server (or slave) is always running on a configured TCP port.

For each of the available serial ports you can define the type of "Task": a serial port can be configured as Modbus RTU Master or Modbus RTU Slave or disabled.

In this way different combinations are possible.

In addition, tags can be read to/from up to 25 Modbus TCP Server.

Finally, you can define some tags that are related to the "embedded" digital I/O present in the device.

The following pictures show some typical scenarios.

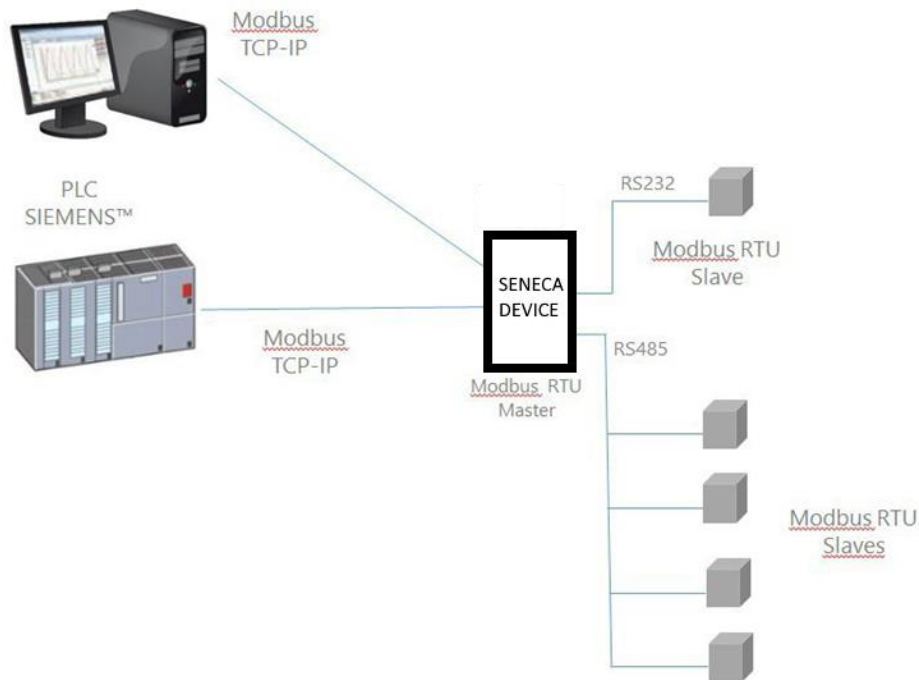

In the figure above, two serial ports are configured as Modbus RTU Master.

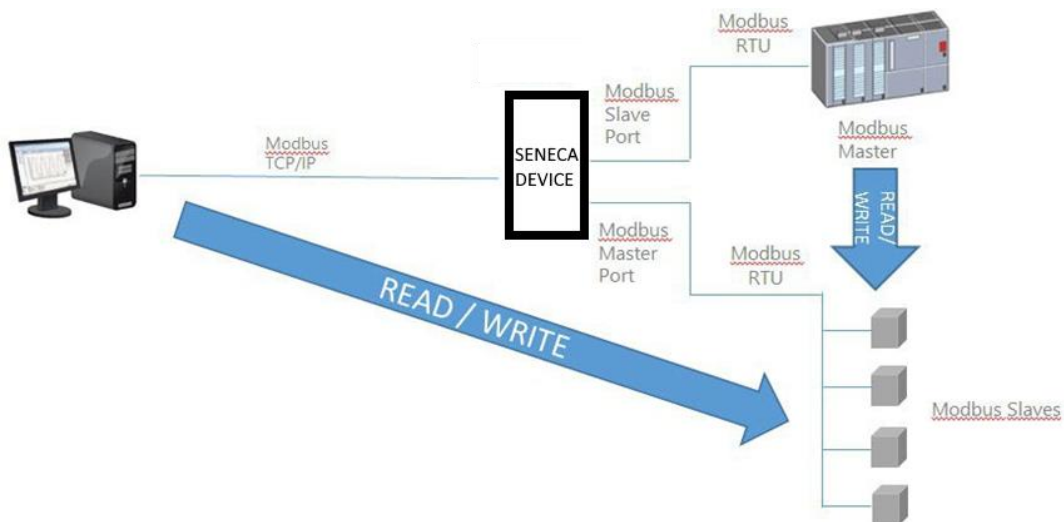

In this case, one serial port is configured as Modbus Slave and another is configured as Modbus Master.

When some registers acquired by the Modbus Slaves must be available for a PLC, which only supports the Modbus Master protocol, the device can be configured with one serial port defined as Modbus Slave (connected to the PLC) and another in Modbus Master (connected to the Modbus Slaves). The PLC Modbus RTU Master and the Modbus TCP client(s) will write/read the shared memory registers of the Seneca device, while the Modbus Gateway keeps the shared memory aligned with the Modbus Slaves registers.

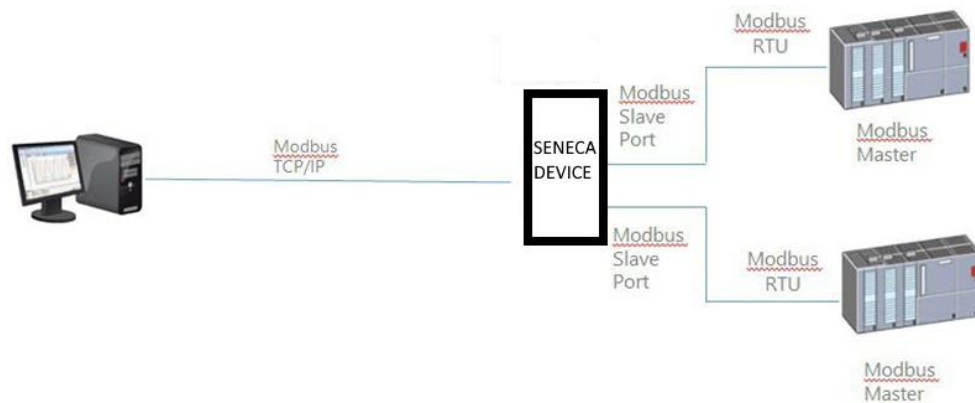

In the figure above, two serial ports are configured as Modbus Slave and connected to a Modbus Master PLC port; in this way, the two PLCs and the Modbus TCP Client can write/read the shared memory to share data.

The Modbus Gateway Shared Memory mode provides some interesting features, as explained below.

In addition to the "classic" behaviour of the gateway, the tags can be configured to operate in "Bridge" mode; this mode allows you to "refresh" the tag values from the serial side only when the gateway receives Modbus TCP/RTU requests for those tags; this can be very useful when using RTU devices with "Fail safe" outputs, where it is necessary to cyclically write the outputs otherwise a fail would occur.

Modbus Gateway Shared Memory also performs request optimization, placing as many registers as possible in a single read/write request; it is possible to set the maximum number of registers in a request independently for each serial port/TCP Server and for read and write operations; this option can be useful for connecting RTU devices that support a maximum number of different registers on different serial ports.

Tag configuration can be created using a Microsoft Excel™ Template provided by Seneca; this template can considerably reduce configuration time, particularly when a large number of tags need to be configured.

## 8. DEVICE CONFIGURATION VIA CONFIGURATION WEBSERVER

The devices can be fully configured via a series of web pages.

### 8.1. "SUMMARY" PAGE

This page shows the main information about the status of the device and the user currently logged in. It is also possible to view the installed firmware version and the activated options.

### 8.2. NETWORK AND SERVICES PAGE

Below are all the configuration parameters available on this page, with a short explanation and the default value of the parameter for each.

#### 8.2.1. NETWORK SECTION

##### ***DHCP ON WAN***

Allows you to activate or not DHCP on the "WAN" Ethernet port

##### ***LAN IP Address***

Allows you to set the IP address of the "LAN" Ethernet port

##### ***LAN Network Mask***

Allows you to set the mask of the "LAN" Ethernet port

##### ***WAN IP Address***

Allows you to set the IP address of the "WAN" Ethernet port

##### ***WAN Network Mask***

Allows you to set the mask of the "WAN" Ethernet port

##### ***Default Gateway***

Allows you to set the default gateway for the "WAN" Ethernet port

##### ***DNS Mode***

Allows you to set whether the DNS should be defined as static or taken from DHCP

##### ***DNS Server***

Allows you to set the IP address of the DNS server

##### ***IP Configuration from Discovery***

Allows you to select whether or not it is possible to change the IP configuration from the Seneca Discovery Device software (Attention: from the Seneca Discovery Device it is possible to change only the settings of the Ethernet port to which you are connected). Please note that for the LAN port it is not possible to activate DHCP.

### 8.2.2. WEB SERVER SECTION

#### **Protocol**

Allows you to select the protocol for the webserver, you can choose between http, https or both.

If you select http you can access the two webservers with the default addresses:

<http://192.168.90.101:8080> e <http://192.168.90.101>

If you select https you can access the two web servers with the default addresses:

<https://192.168.90.101/maintenance> e <https://192.168.90.101>

#### **HTTP Conf Port**

Allows you to set the configuration webserver port

#### **HTTP Remote Display Port**

Allows you to set the virtual display webserver port

### 8.2.3. FILE TRANSFER SECTION

#### **Protocol**

Allows you to configure whether or not to enable the SFTP server protocol for accessing the device's file system.

#### **SFTP Port**

Allows you to configure the port for the SFTP server.

### 8.2.4. DATA FOLDER SHARING SECTION

#### **Enable**

Allows you to enable or disable the sharing of the data/folder from Windows devices via Samba protocol.

### 8.2.5. NETWORK REDUNDANCY SECTION

#### **Enable**

Allows you to enable and select the communication redundancy strategy.

You can choose between the following configurations:

OFF -> Redundancy is disabled

WAN/MOBILE -> If communication to the server set via the WAN Ethernet port is interrupted, it enables communication via Mobile modem (if available).

MOBILE/WAN-> If communication to the server set via the Mobile modem is interrupted, it enables communication via the WAN Ethernet port.

WAN/WIFI-> If communication to the server set via the WAN Ethernet port is interrupted, it enables communication via WIFI.

WIFI/WAN-> If communication to the server set via WIFI is interrupted, it enables communication via the WAN Ethernet port.

### ***Ping Address***

Allows you to set the address of the server to reach to use as a test for redundancy (attention: for redundancy to work, the server must respond to the ping request)

### **8.2.6. R-COMM SECTION (for R-PASS model only)**

#### ***R-COMMM Available***

If enabled, it activates control of the optional R-COMM module

#### ***R-COMM UPS Mode***

It configures the UPS operating mode present in the R-COMM module.

Important: Check that the R-COMM model purchased has the "UPS" function before configuring these parameters.

If the R-COMM purchased does not include the UPS, this parameter must be set to "OFF".

OFF-> does not use R-COMM UPS to power R-PASS

Shutdown immediatly-> in case of mains power failure closes the log files and performs a clean shutdown of R-PASS

Shutdown on low power-> in case of a mains power failure R-PASS continues to work as long as the battery is charged, when it is discharging it closes the log files and performs a clean shutdown of R-PASS

### **8.2.7. WATCHDOG SECTION**

#### ***Enable***

If enabled, it allows a reboot if the device remains blocked for a time equal to the watchdog timeout.

#### ***Timeout***

It represents the time in seconds that the device can remain blocked before performing a reboot.

### **8.2.8. DEBUG LOGS SECTION**

#### ***Enable***

If enabled, it creates log files to be analysed by Seneca technicians.

The log files can be downloaded from the "Conf. Management" page of the webserver



## 8.3. PLC CONFIGURATION PAGE

### 8.3.1. STRATON PLC SECTION

**Enable**

Allows you to activate or deactivate the Straton PLC

**TCP Port**

Allows you to set the port for the connection with the Straton environment (IDE)

**Redundancy Enable**

Allows you to enable or disable the redundancy of the Straton PLC, 2 identical devices are created, one of which is automatically set as master and one as slave. The devices continuously exchange information between each other. If one becomes unavailable, the other is activated virtually without loss of continuity.

For more information, refer to the Straton PLC manual.

**Redundancy IP Address**

Allows you to set the IP address of the second PLC that is part of the redundancy.

**License Key**

Allows you to activate the Energy protocols (IEC61850, IEC60870-5-104 or IEC60870-5-101).

The key to be entered is sent by Seneca support in case of purchase of the respective licenses.

**Retain Variables Enable**

Allows you to configure how retain-type TAGs are to be managed (only if the Straton PLC is set to “shared” mode).

A Retain-type Tag is cyclically saved in a non-volatile memory so that, in the event of a device shutdown, it does not lose the acquired value.

A classic case is the value of an energy meter.

If set to OFF: the retain variables are managed by the firmware, if set to ON the management of the retain variables is done by the PLC.

### 8.3.2. Real-Time Behaviour SECTION

#### **ENABLE**

Enables Real Time mode in the PLC

By enabling this function, the operating system scheduler switches to Real Time mode and allows you to manage the PLC by reducing the Jitter of the PLC cycle times.

If a real time protocol is used in the PLC, it is recommended to enable this function.

## 8.4. PLC MODBUS CONF. PAGE

### 8.4.1. Modbus TCP Client SECTION

These parameters allow you to set the IP address and the port of the Modbus TCP-IP server to which the Modbus TCP-IP client of the Straton PLC must connect without statically entering them in the IDE configuration.

This is very useful in case you need to create multiple PLCs that point to different Modbus TCP-IP servers without recompiling the Straton project each time.

In order for Straton to use these parameters, you must use the following text instead of the IP and Port value of the Modbus TCP-IP server:

```
mbtcpcli_param
```

at this point the IP address and the port will be replaced with the values set here.

#### **IP Address**

Allows you to set the IP address of the Modbus TCP-IP server to connect to via the Straton Modbus TCP-IP client.

Attention: in the Straton IDE you must enter the text:

```
mbtcpcli_param
```

instead of the IP address.

#### **TCP Port**

Allows you to set the Modbus TCP-IP server port to connect to via the Straton Modbus TCP-IP client.

Attention: in the Straton IDE you must enter the text:

```
mbtcpcli_param
```

instead of the TCP Port.

### 8.4.2. Modbus Pass-through SECTION

This function is only available if the Straton PLC is active

#### **Enable**

If enabled, it allows you to activate the modbus passthrough when the Straton PLC is running. Any modbus TCP-IP request arriving at the set port will be forwarded to the COM2 serial port.

Only if you use the Z-NET software to configure the device, you can change the COM2 port with another one.

#### **TCP Port**

This is the port used for Modbus passthrough.

## 8.5. SERIAL PORTS PAGE

The Mode parameter affects both the firmware Gateway and the Straton PLC, while the other properties of the serial ports refer to the Gateway features of the firmware of the devices. If the Straton PLC uses the same serial port, the parameters configured here (baud, bits no., etc.) will be overwritten and will therefore have no effect (those defined in the Straton PLC have priority).

### 8.5.1. COM1 SECTION (RS485/RS232/MBUS)

#### **Mode**

Selects the type of serial to use for COM1 (both for the PLC and for the firmware): RS232, RS485 or RS232-MeterBus (via optional Z-MBUS device).

#### **Baud Rate**

This is the baud rate at which the serial port must operate.

#### **Data Bits**

This is the number of bits at which the serial port must operate.

#### **Parity**

This defines whether parity should be used and what type.

#### **Stop Bits**

This defines whether or not to use stop bits.

### 8.5.2. COM2 SECTION (RS485)

#### **Mode**

Selects the serial type to use for COM2 (both for the PLC and for the firmware): for COM2 you can only choose RS485.

**Baud Rate**

This is the baud rate at which the serial port must operate.

**Data Bits**

This is the number of bits at which the serial port must operate.

**Parity**

This defines whether parity should be used and what type.

**Stop Bits**

This defines whether or not to use stop bits.

**8.5.3. COM4 SECTION (RS485)**

This port is only available in the Z-PASS1/2-RT, Z-TWS4-RT models.

**Mode**

Selects the serial type to use for COM2 (both for the PLC and for the firmware): for COM4 you can only choose RS485.

**Baud Rate**

This is the baud rate at which the serial port must operate.

**Data Bits**

This is the number of bits at which the serial port must operate.

**Parity**

This defines whether parity should be used and what type.

**Stop Bits**

This defines whether or not to use stop bits.

**8.6. WI-FI CONFIGURATION PAGE**

This page is only available on models with a Wifi port.

**Mode**

You can select from:

OFF: The WI-FI port is off

Station: The WI-FI is connected to an existing network

Access Point: The device creates a new WI-FI network to which devices can connect

**SSID**

If Mode is "Access Point" you can define the name of the new WI-FI network that the device will create.  
If Mode is valid "Station" displays the SSID of the network you are connected to.

**KEY MODE**

Represents the encryption protocol to be used.

**SCAN/APPLY**

Allows, in Station mode, to select the WI-FI to connect to

**8.7. I/O CONFIGURATION PAGE**

In this page you can configure the IOs on board the device.

**8.7.1. Digital I/O Configuration SECTION**

This section allows you to configure the digital IOs.  
Each device model has a different digital IO configuration:

**SSD MODEL*****Input/Output 1 Mode***

It is possible to choose between:

***Remote Connection Disable***

The channel is set as INPUT and if set LOW it enables the possibility of opening a remote VPN connection with the device, if set HIGH every VPN connection is blocked.

***General Input***

The channel is set as general digital Input

***General Output***

The channel is set as general digital Output

***Input/Output 2 Mode***

It is possible to choose between:

***Remote Connection Active***

The channel is set as OUTPUT, if OPEN it means that no VPN connection is active. If CLOSED it means that a VPN connection is in progress.

**Local alarm**

The channel is set as an input that is typically connected to an external control PLC, when it is HIGH it indicates a general error that is visible remotely via the Seneca VPN BOX1 status interface, currently this parameter is not used by VPN BOX2.

**Remote toggle**

Currently not used

**General Input**

The channel is set as general digital Input

**General Output**

The channel is set as general digital Output

**R-PASS MODEL****Input 1 Mode**

It is possible to choose between:

*Remote Connection Disable*

The channel is set as INPUT and if set to LOW it enables the possibility of opening a remote VPN connection with the device, if set to HIGH every VPN connection is blocked

*General Input*

The channel is set as general digital Input

**Input 2 Mode**

It is possible to choose between:

*Local alarm*

The input is typically connected to an external control PLC, when HIGH it indicates a general error that is visible remotely via the Seneca VPN BOX1 status interface, currently this parameter is not used by VPN BOX2.

*General Input*

The channel is set as general digital Input

**Input 3 Mode***General Input*

The channel is set as general digital Input

**Input 4 Mode***General Input*

The channel is set as general digital Input

**Output 1 Mode**

It is possible to choose between:

*Remote Connection Active*

If OPEN it means that no VPN connection is active. If CLOSED it means that a VPN connection is in progress.

*Remote toggle*

Currently not used

*General Output*

The channel is set as general digital Output

**Output 2 Mode***General Output*

The channel is set as general digital Output

**Output 3 Mode***General Output*

The channel is set as general digital Output

**Output 4 Mode***General Output*

The channel is set as general digital Output

**Z-PASS1/2 MODEL****Input/Output 1 Mode**

It is possible to choose between:

**Remote Connection Disable**

The channel is set as INPUT and if set LOW it enables the possibility of opening a remote VPN connection with the device, if set HIGH every VPN connection is blocked.

**General Input**

The channel is set as general digital Input

**General Output**

The channel is set as general digital Output

**Input/Output 2 Mode**

It is possible to choose between:

**Remote Connection Active**

The channel is set as OUTPUT, if OPEN it means that no VPN connection is active. If CLOSED it means that a VPN connection is in progress.

**General Input**

The channel is set as general digital Input

**General Output**

The channel is set as general digital Output

**Input/Output 3 Mode****General Input**

The channel is set as general digital Input

**General Output**

The channel is set as general digital Output

**Local alarm**

The channel is set as an input that is typically connected to an external control PLC, when it is HIGH it indicates a general error that is visible remotely via the Seneca VPN BOX1 status interface, currently this parameter is not used by VPN BOX2.

**Input/Output 4 Mode****General Input**

The channel is set as general digital Input

**General Output**

The channel is set as general digital Output

**Remote toggle**

Currently not used

**Input/Output 5 Mode****General Input**



The channel is set as general digital Input

**General Output**

The channel is set as general digital Output

**Input/Output 6 Mode****General Input**

The channel is set as general digital Input

**General Output**

The channel is set as general digital Output

**8.7.2. Analog I/O Configuration SECTION**

Allows you to configure the analog inputs (not present in the SSD product)

**Analog Input 1 Mode**

You can choose whether to set the input as Voltage (0-10V) or Current (0-20mA) input.

**Analog Input 2 Mode**

You can choose whether to set the input as Voltage (0-10V) or Current (0-20mA) input.

**8.7.3. Security Level SECTION****Service Disable**

This parameter defines which access services are disabled when the "Remote Connection Disable" digital input is HIGH.

The possible values are:

*VPN Connection:* VPN connection block (Service VPN channel and Internet active)

*VPN Service:* VPN service channel block (active Internet)

*Internet Connection:* Blocking of internet access (both internet and VPN are blocked in the device)

*SMS Service:* The modem is turned off and therefore it is not possible to receive SMS messages.

## 8.8. REAL TIME CLOCK SETUP PAGE

This page allows you to set the device date/time parameters.  
The date/time is maintained for a few days even without supplying power.

### 8.8.1. NTP SECTION

The Network Time Protocol, in acronym NTP, is a protocol to synchronize the clocks of the devices connected within a network. The NTP is a client-server protocol belonging to the application layer and listens on UDP port 123.

#### **Enable**

Enables or disables time acquisition from the set NTP servers. Synchronization occurs every 5 minutes.

#### **Server primary**

IP or FQDN address of the primary NTP Server

#### **Secondary server**

IP or FQDN address of the secondary NTP Server

#### **Timezone**

Time zone setting

### 8.8.2. RTC SECTION

In case of disabled NTP server, it is possible to manually set the date/time or acquire it directly from the connected PL.

## 8.9. GATEWAY CONFIGURATION PAGE

This page allows you to activate and configure the Ethernet-Serial Gateway you want to use.  
For each serial port (depending on the device model, the number of serial ports is different) you can choose between:

#### **Modbus Ethernet to Serial**

This is a real-time conversion from Ethernet port to serial port from the Modbus TCP-IP protocol to serial RTU Modbus.

#### **Transparent**

This is a real-time conversion from an Ethernet port to a serial port independent of the protocol.

#### **Modbus Shared Memory**

In this mode, acquisitions are made from serial (towards a Modbus RTU slave) or from Ethernet (towards a Modbus TCP-IP server) and imported into an internal memory. This mode is essential for using the data logger, client protocols and the cloud.

 **ATTENTION!**

*In order to use the data logger, client protocols (e.g. MQTT) and logical rules, you need to set the gateway operating mode to Modbus Shared Memory.*

*None*

The serial port is free or usable by the Straton PLC protocols (such as MeterBUS).

For more information on the Gateway operating modes, refer to the respective chapter of this manual.

### 8.9.1. Modbus Shared Memory SECTION

This section contains the configurations relating to access to the shared memory of the Modbus Shared Memory mode.

#### **TCP Enable**

This parameter enables/disables the Modbus Shared Memory Gateway service.

It is important to note that when this parameter is set to OFF, the Modbus TCP-IP server service is not running even if some serial ports are assigned to it.

#### **TCP Port**

Sets the listening port for the Shared Memory Modbus TCP server

#### **TCP Connections Max Number [1-50]**

Maximum number of TCP connections that can be accepted by the Modbus TCP server

#### **Response Mode when Resource in Fail**

This parameter defines how the response to a Modbus request (read) for a tag corresponding to a non-responding Modbus station is constructed; when mode is "Tag error value", the value in the Modbus response is given according to the "Error Mode" / "Error Value" parameters in the tag definition; when mode is "Exception", the response contains an exception with the value 11 ("Gateway target device failed to respond").

#### **Diagnostic Area Type**

Select whether diagnostics can be accessed via Modbus Holding Registers or Modbus Input Registers.

#### **Diagnostic Area Address**

Defines the starting register of the TAG diagnostic area.

The diagnostic area reserves a bit for each configured tag (125 registers) and provides the FAIL/OK status:

Bit value on 0 -> means Tag reading error (or tag not configured)

The bit value on 1 -> means Reading tag OK

Therefore, if you need to check the error status of the first 10 tags using the default area (9001 Holding Registers), you must read the 49001 registry.

For instance, if the value of the register is:

0x3DB = 987 = 0000 0011 1101 1011

Tag 1 = OK

Tag 2 = OK

Tag 3 = FAIL

Tag 4 = OK

Tag 5 = OK

Tag 6 = FAIL

...

Note that one register before and one register after the diagnostic area will be reserved (by default registers 49000 and 49126 or 39000 and 39126).

### ***Internal Write Functions***

Allows you to choose how the TAGs are written to the Modbus registers of the slave or server devices.

This includes writings with the "SET" button of the TAG webserver page or writings of the logical rules.

### **8.9.2. Modbus Ethernet to Serial e Modbus Shared Memory SECTION**

This section allows you to configure the Slave ID address (station modbus address) to which the device responds with its embedded IOs.

The registers representing the I/Os are accessible via Modbus TCP-IP or RTU protocol.

The addresses of the modbus registers vary depending on the model and are defined in the respective chapter of this manual

### **8.9.3. COM0, COM1, COM2, COM4 SECTION (DEPENDSING ON THE MODEL)**

Here you can set the parameters related to the gateway mode that has been chosen for each serial port.

The COM0 port is available when a USB-to-serial converter is connected

#### **8.9.3.1. COM0 (USB)**

Depending on the mode chosen for the port (in this case only Transparent mode is available) you can set the parameters:

### ***Operating Mode***

For the COM0 port, only the "Virtual COM" mode can be selected.

**Listen Port**

It is the port on which the Virtual port mode server works.

**Data Packet Interval (ms)**

It is the time interval that marks the end of a packet, this parameter must be set based on the type of protocol that is transiting

**8.9.3.1. COM1 (RS232/RS485) COM2 (RS485) COM4 (RS485)**

Depending on the mode chosen for the port, the following parameters are available

**8.9.3.1.1. COM1/COM2/COM4 Modbus Ethernet to Serial**

Allows you to set the parameters of the Ethernet to Serial Gateway mode

**Enable**

Enables or disables Ethernet to Serial mode on the serial port

**Port**

Sets the TCP port on which the Ethernet to Serial gateway will operate

**Response wait time [ms]**

Sets the serial wait time to declare a timeout

**8.9.3.1.2. COM1/COM2/COM4 Transparent**

Allows you to set the operation of the transparent mode.

**Operating Mode**

For COM1/COM4 ports you can choose between:

VIRTUAL COM

SERIAL TUNNEL POINT TO POINT ON TCP

SERIAL TUNNEL POINT TO POINT ON UDP

**8.9.3.1.2.1. COM1/COM2/COM4 VIRTUAL COM**

Allows you to set the parameters of the Ethernet to Serial Gateway mode

**Enable**

Enables or disables Ethernet to Serial mode on the serial port

**Port**

Sets the TCP port on which the Ethernet to Serial gateway will operate

**Response wait time [ms]**

Sets the serial wait time to declare a timeout

**8.9.3.1.2.2. COM1/COM2/COM4 SERIAL TUNNEL POINT TO POINT ON TCP/UDP****Tunnel Role**

Sets the tunnel as master or slave

**Destination Address**

If the Tunnel Role is master it is the IP address of the remote Tunnel Role Slave

**Destination Port**

If the Tunnel Role is master the Listen Port of the Tunnel Role is slave

**Listen Port**

If the Tunnel Role is set to slave it is the listening port of the remote master tunnel

**8.9.3.1.2.1. COM1/COM2/COM4 MODBUS SHARED GATEWAY****Task**

Allows you to select the type of task Modbus Shared Gateway that must be executed on the selected serial port between:

None, Master, Slave or Sniffer

**None**

No active task

**Master**

The gateway's Modbus RTU master is active to acquire data from Modbus RTU slave devices.

**Slave**

The gateway's modbus RTU slave is active to accept connections from a modbus RTU master

**Sniffer**

The serial sniffer is active, that is, it acquires the modbus RTU protocol from the serial port passively. It is used in existing systems (when there is already a modbus master and one or more modbus slaves) and you want to acquire data passively.

**Slave Address**

In Task = Slave mode, it is the value of the slave address (station address) that the serial port must assume.

**Timeout (ms)**

In Task = Master mode it is the response Timeout for Modbus RTU requests, in milliseconds

**Delay between Polls (ms)**

In Task = Master mode it is the interval between Modbus RTU requests, in milliseconds

**Read/Write Retries**

In Task = Master mode this is the maximum number of retries for Modbus RTU requests; this always applies to write requests; for read requests, it only applies to tags with "Tag mode" = "BRIDGE"

**Multiple Read Max Number**

In Task = Master mode, this is the maximum number of Modbus registers that can be read in a single Modbus RTU request; it is used to reduce the number of read requests sent on the serial bus (thanks to this parameter the firmware autonomously performs an optimization)

**Multiple Write Max Number**

In Task = Master mode, this is the maximum number of Modbus registers that can be written in a single Modbus RTU request; it is used to reduce the number of write requests sent on the serial bus (thanks to this parameter the firmware autonomously performs an optimization)

**Validity Timeout**

In Task = sniffer mode if a certain tag is not seen refreshed in the communication for the set time then it is set to FAIL.

**8.10. VPN CONFIGURATION PAGE**

This page allows you to configure a VPN, Seneca devices support two types of VPN: VPN BOX or OPEN VPN. For more information on the VPN BOX server, refer to the VPN chapter in this manual.

**VPN MODE**

Allows you to choose the type of VPN server to connect to, you can choose between OPEN VPN or VPN BOX.

The installed version of OPEN VPN is 2.4.7

**8.10.1.VPN FILES SECTION**

In the case of a VPN connection with an OPEN VPN server, this section allows you to upload the configuration file and any certificates.

The configuration file must contain all the information needed to configure the behaviour of Open VPN.

The main configuration options are:

- whether the device will function as a client or server (generally, it will be a client)
- the transport protocol (UDP or TCP)
- the IP address of the server / host name and port
- the files needed to perform authentication procedures
- etc...

This file has the extension ".ovpn" (on Windows systems) or the extension ".conf" (on Linux systems). Regardless of the original name, it will be renamed to "ovpn.conf" on the device.

This is the only mandatory file, i.e. if this file has not been uploaded to the device the VPN cannot be enabled. As mentioned in the Web page, in the options that require a file argument, only the file name, without path, must be provided, as in the following example:

```
ca ca.crt OK  
ca /home/config/vpn/ca.crt FAIL
```

Two other important rules that must be followed are:

- the "dev" option must be: "dev tun0" or "dev tap0".
- the "log" option must be omitted (so that logs are written to syslog)

For more information about the OPEN VPN configuration file, please refer to the OPEN VPN 2.4 documentation at the link:

<https://openvpn.net/community-resources/reference-manual-for-openvpn-2-4/>

### **CA CERTIFICATE**

This file must contain the certificate of the certification authority (CA) and has the extension .crt. This is required when the configuration file contains the "ca" option.

### **CLIENT CERTIFICATE**

This file must contain the client certificate and has the extension .crt. This is required when the configuration file contains the "cert" option.

### **CLIENT KEY**

This file must contain the client key and has the extension .key.



This is required when the configuration file contains the "key" option.

### **ADDITIONAL FILE**

This file can be of any type and may be required for configuration options other than "ca", "cert" and "key". Note that you can upload more than one additional file.

You can choose files from your PC to select files and send them to the device by pressing the "UPLOAD" button. When loading is complete, a results page is displayed

You can check which VPN files are stored on your device by clicking the "SHOW VPN STATUS" button,

As the web page recalls, VPN files can be downloaded from the device, if necessary, via FTP / SFTP; they can be found in the /home/config/vpn directory.

You can clear all VPN files by clicking the "RESET" button; a pop-up will appear, asking for confirmation.

When you press the "SHOW VPN STATUS" button, a third section called "VPN Status" appears, which shows:

- The "Connection Status" of the VPN (i.e. "Stopped" or "Running")
- the IP address assigned to the VPN interface when "Connected", the "dummy" IP address "0.0.0.0" when "Disconnected".
- the "OpenVPN Status" (i.e.: "Stopped" or "Running")
- the number of packets / bytes received by the VPN interface when connected; "0/0" when disconnected
- the number of packets / bytes sent to the VPN interface when connected; "0/0" when disconnected
- VPN files stored on the device

Important status information is given by the "OpenVPN Status" field; if the VPN is enabled ("ON"), but this status is "Stopped", this means that the Open VPN process cannot be started correctly: probably, the configuration file contains some errors or, perhaps, some options not supported by the OpenVpn implementation of the device.

You can update the VPN status by clicking the "REFRESH" button.

Finally, you can hide the "VPN Status" section by clicking the "HIDE VPN STATUS" button.

### **8.10.2.OPEN VPN SECTION**

#### **Enable**

Flag to enable/disable the "Open VPN" feature

#### **Allowed Interface**

Allows you to force the VPN connection through the specified interface.

#### **Reply on WAN to packets coming from WAN**

If enabled, it allows responses to packets coming from the WAN interface to be sent to the same interface and not (for example) via the VPN.

**8.10.3.VPN BOX SECTION**

**Enable**

Flag to enable / disable the "VPN Box" feature, i.e. the procedure / protocol that allows the device to configure the VPN, interacting with the "VPN Box" server (see "VPN Box User Manual")

**Server**

IP or FQDN address of the "VPN Box" or "VPN Box 2" server

**Password**

Password to access the "VPN Box" server

**Tag Name**

Mnemonic name used to uniquely identify the device

When you click the "SHOW VPN STATUS" button, a new section called "VPN Status" is displayed:

- VPN connection status
- the VPN IP address assigned to the device this line is not displayed for the VPN "Point-to-Point (L2)" box, as no IP address is assigned to the VPN interface
- the status of OpenVPN
- the number of packets / bytes received by the VPN interface
- the number of packets / bytes sent to the VPN interface
- the Type of VPN BOX, which can be "Point-to-Point", "Point-to-Point (L2)" or "Single LAN"
- the status of the VPN BOX, if the VPN box is enabled
- the user name of the connected user, if any

The following table gives a brief explanation of the possible "Result" and "Status" strings:

Result	Status	Meaning
Error (Unexpected response)		A response code has been received that is not managed by the device (should never occur)
Error (No response from VPN Box)		No response received from VPN Box (response timeout)
Error (Invalid response from VPN Box)		A response was received whose content is not valid for the device (should never occur)
Error (Wrong password)		The password set on the device is incorrect
Error (License Limit Reached)		The maximum number of devices allowed by the license is already registered on VPN Box
Error (VPN Box not configured)		The VPN Box has not yet been configured
Error (Generic error)		A generic error has occurred on VPN Box
OK		The device has just been registered on VPN Box

OK	New	The device is registered on VPN Box, but not yet configured (only "single LAN")
OK	Configuration updated	The device configuration has just been updated
OK	Configured	The device is correctly configured and available for VPN connection
OK	Ban	The device has been "banned"
OK	Not found	The device is not known to VPN Box; this happens when the device registration is deleted on VPN Box
OK	Unknown	The device has an unknown status in VPN Box (should never occur)
OK	Not bound	The "tunnel" between device and VPN Box is not active; this may occur when the tunnel port is blocked (not open) in the ADSL router on the VPN Box side (only "Point-to-Point")
OK	Unexpected status	A status code has been received that is not managed by the device (should never occur)

### 8.11. OPC-UA SERVER CONFIGURATION PAGE

In this page, you can set parameters related to the OPC Unified Architecture (OPC-UA) server integrated into the gateway.

The device's OPC-UA server "exports" the Modbus Shared Memory Gateway tags; therefore, using an OPC-UA client software, it is possible to read / write tags using the OPC-UA protocol.

NOTE: for all variables on the OPC-UA server the namespace-id is set to "1".

#### 8.11.1. OPC- UA Server Conf. SECTION

##### **Enable**

Enables/Disables the OPC-UA server, once enabled the server is available at the URL:

opc.tcp://IP\_Address:Port/

##### **Port**

Sets the port for the OPC-UA server.

##### **Username**

Username for server access

**Password**

Password for server access

**Security Policy**

It is possible to choose between:

“None”

“Basic128Rsa15”

“Basic256Sha256”

**8.11.1.1.OPC- UA SERVER CERTYIFICATES SECTION**

A default pair of certificates is already included in the product, you can also add your own certificates with the appropriate buttons.

## 8.12. OPC-UA CLIENT CONFIGURATION PAGE

In this page you can upload the server connection certificates for the OPC-UA client.

*OPC-UA Client Certificates*

*.crt,.cer,.key,.pem files must be in PEM (ASCII) format.*

*.der files must be in DER (binary) format.*

Client certificate	<input type="button" value="Scegli file"/>	Nessun file selezionato
Client private key	<input type="button" value="Scegli file"/>	Nessun file selezionato
Trusted certificate 1	<input type="button" value="Scegli file"/>	Nessun file selezionato
Trusted certificate 2	<input type="button" value="Scegli file"/>	Nessun file selezionato
Trusted certificate 3	<input type="button" value="Scegli file"/>	Nessun file selezionato
Trusted certificate 4	<input type="button" value="Scegli file"/>	Nessun file selezionato
Trusted certificate 5	<input type="button" value="Scegli file"/>	Nessun file selezionato
Trusted certificate 6	<input type="button" value="Scegli file"/>	Nessun file selezionato
Trusted certificate 7	<input type="button" value="Scegli file"/>	Nessun file selezionato
Trusted certificate 8	<input type="button" value="Scegli file"/>	Nessun file selezionato
Trusted certificate 9	<input type="button" value="Scegli file"/>	Nessun file selezionato
Trusted certificate 10	<input type="button" value="Scegli file"/>	Nessun file selezionato

The "Choose File" button selects the certificate. These are only uploaded to the device after pressing the "Upload" button.

The "Show Certificate Files" button allows you to view the uploaded certificate files.

The "Restore Default Certificate Files" button allows you to restore the default certificate files.

### 8.13. SNMP CONFIGURATION PAGE

This page describes the configuration of the SNMP Agent.  
The SNMP V2C version is supported.  
The protocol can only be used if the Straton PLC is enabled.

#### 8.13.1.GENERAL CONFIGURATION SECTION

**Enable**

Enables or not the SNMP protocol

**Port**

Port used by the SNMP protocol

**Trap Type**

Selects the type of Trap to use

**Trap Port**

Port used by Traps

**Allow access from any host**

When this parameter is disabled, access will be allowed only to the hosts listed below with "Access" selected.

#### 8.13.2.COMMUNITIES SECTION

**Name**

Community identifier

**Read**

Provides Read properties to the selected Community

**Write**

Provides Write properties to the selected Community

#### 8.13.3.HOSTS SECTION

**IP Address**

Allows you to define the Host IP

**Community**

Allows you to define which community the Host is associated with

**Access**

If Flagged, it allows the host to access the SNMP Agent

**Trap**

If Flagged, it allows the host to receive Traps from the SNMP Agent

**8.14. USERS CONFIGURATIONS PAGE**

This page shows the configuration (user/password) of all the accounts available for access to the Webserver and the Display.

You can only enter one user per type.

**WEB / DISPLAY ADMINISTRATOR**

This is the account that allows all operations both on the configuration webserver and on the one relating to the display (and to the display on models equipped with it).

**WEB / DISPLAY OPERATOR**

This is the account that allows access only to some pages of the configuration webserver, while in the display webserver and in the physical display it allows you to block access to the setup menu.

**WEB / DISPLAY GUEST**

This is the account that allows access to almost all pages except for the advanced maintenance pages (for example, it does not allow access to the “FW Upgrade” and “Configuration Management” pages). It can view all configuration parameters and status information, but cannot change any parameters.

Consequently, on all pages, the “APPLY” buttons (and any other buttons used to make changes) are disabled.

**FTP USER**

This is the account for accessing the FTP server of the device.

**8.15. ROUTER CONFIGURATION PAGE**

On this page you can change the parameters related to the functionality of the router.

**Router Enable**

Enable/Disable router functionality

**DNS Enable**

Flag to enable/disable the DNS forwarding service

**DHCP Server Enable**

Flag to enable / disable DHCP service (DHCP server)

**DHCP First Address**

***DHCP Last Address***

These parameters define the range of IP addresses assigned by the DHCP server to requesting clients

***DHCP Lease Time (min)***

Validity time interval for IP address assignment, in minutes.

***Use Local Addresses Through VPN/Enable***

Flag to enable/disable access to the device and others that are connected to the LAN, using their local IP (LAN) addresses

***Mobile network firewall***

Allows you to enable or disable the firewall on the mobile network (if available).

**8.16. PORT MAPPING RULES PAGE**

On this page you can set up port mapping rules (also known as "virtual servers").

***Protocol***

This parameter defines the transport protocol (or port type) affected by the rule: TCP, UDP or both

***External Port***

TCP or UDP port to which a packet was originally sent

***Server IP Address***

IP address to which the received packet is forwarded

***Internal Port***

TCP or UDP port to which the received packet is forwarded

For example, if you set the values:

*Protocol = TCP-IP*

*External Port = 502*

*Server IP Address = 192.168.85.103*

*Internal Port = 503*

The rule tells the device that any TCP or UDP packet received by the gateway on port 502 (which is often used for the Modbus TCP protocol) should be forwarded to the IP address 192.168. 85.103 (which corresponds to another device) on the same destination port 503.

**8.17. NAT 1:1 RULES PAGE**

You can use this page to access a device (for example a PC) from the WAN to the LAN.



You then want to access a PC connected in the WAN to a PLC connected in the LAN network as shown in the figure:

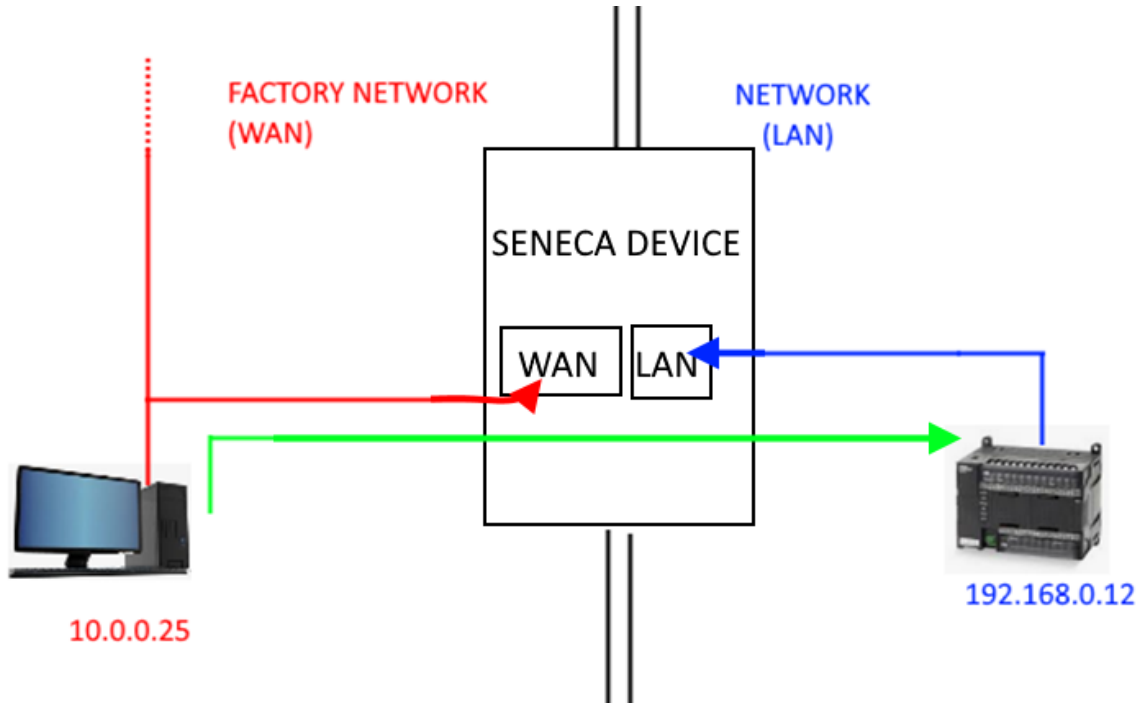

It is necessary to create a new address (10.0.0.26) which is located on a PC-compatible network (10.0.0.25).

	CURRENT	UPDATED
<i>NAT 1:1 Configuration</i>		
Interface		WAN
Device IP Address		192.168.0.12
Mapped IP Address		10.0.0.26
Description		WAN to LAN ACCESS1
<input type="button" value="APPLY"/>		

PLC 192.168.0.12 is now accessible from the WAN using address 10.0.0.26.

**Interface**

Allows you to choose the interface among those available

**Device IP Address**

It is the address of the device that must be reached

**Mapped IP Address**

It is the new virtual IP address that must be compatible with the selected network (interface)

**Description**

It is the mnemonic description of the rule

## 8.18. STATIC ROUTES PAGE

This page allows you to set static routes, this function allows you to route an address or a range of addresses to different gateways.

For example, if you need to reach 2 different addresses: 192.168.85.23 and 192.168.82.56 but you need to go through 2 different gateways.

### ***Destination Address***

It is the destination address to reach

### ***Subnet Mask***

It is the subnet mask

### ***Gateway***

It is the address of the gateway that it must pass through

### ***Interface***

It is the used interface

### ***Description***

It is the mnemonic text of the rule

For example, you have:

- 1) To access 192.168.85.23 it is necessary to pass through gateway 192.168.80.1
- 2) To access 192.168.82.56 it is necessary to pass through gateway 192.168.80.100

You will have to use the configuration:

Rule #1:

Destination Address = 192.168.85.23

Subnet Mask = 255.255.255.255

Gateway = 192.168.80.1

Interface = LAN

Description = Go to 85

Rule #2:

Destination Address = 192.168.82.56

Subnet Mask = 255.255.255.255

Gateway = 192.168.80.100

Interface = LAN

Description = Go to 82

## 8.19. MOBILE NETWORK PAGE (Mobile Configuration)

This page allows you to configure your mobile connection (if present).

### 8.19.1.SIM SECTION

#### ***PIN***

This is the PIN number to access the SIM (if configured)

### 8.19.2.OPERATOR SELECTOR SECTION

#### ***Mode***

You can choose the strategy to select the mobile operator:

Automatic: the operator is chosen automatically

Manual: the operator is set manually, if the operator is not available, the connection cannot take place

Manual/Automatic: allows you to set the operator in manual mode but if the operator is not available the system will switch to “automatic” mode.

#### ***Operator***

Allows you to select the operator manually, to display a list of available operators in the area you need to press the “Get Operator List” button

### 8.19.3. DATA CONNECTION SECTION

**Enable**

Enables or disables the use of mobile data.

**APN Mode**

It allows you to manually set the APN or use the auto APN (the APN is retrieved from an internal database). Attention, the database does not contain all the possible world APNs but only the main ones.

**APN**

This is the APN (access point that allows mobile devices to use an Internet connection) currently used or to be used.

**Authentication Type**

This is the type of authentication to use for the APN

**Username**

This is the username for the APN

**Password**

This is the password for the APN

**Host for connection check (ping)**

This is the URL or IP that the device uses to diagnose the mobile connection.

**Set Default Gateway**

Allows you not to set a default gateway for the mobile network (and therefore to keep the default gateway of the WAN or WIFI network).

### 8.20. DDNS CONFIGURATION PAGE (Mobile Configuration)

This page allows you to configure DDNS services. Dynamic DNS (DDNS) is a technology that allows a DNS name on the Internet to always be associated with the IP address of the same host, even if the address changes over time.

**TYPE**

Allows you to choose the DDNS service to use from those listed.

**Hostname**

This is the DDNS hostname

**Username**

*This is the username for the service*

**Password**

This is the password for the service

**8.21. TCP SERVERS PAGE (Shared Memory Tag Conf.)**

This page shows the list of remote Modbus TCP servers, used to acquire data in the Modbus Shared Memory Gateway function.

By clicking on the "ADD" button you can configure a new TCP server, as in the figure below:

		ADD	MODIFY		DELETE				
#	Name	IP Address	TCP Port	Timeout	Poll Delay	Read/Write Retries	Mult.Read Max Num.	Mult.Write Max Num.	
1	ZPASS2_105	192.168.105.101	502	5000	100	0	16	16	
2	ZPASS2_106	192.168.106.101	1100	5000	100	0	16	16	
3	ZKEY_83	192.168.85.83	502	500	100	0	16	16	
4	ZPASS2S_103	192.168.107.101	502	5000	100	0	16	16	

**Name**

TCP Server Mnemonic Name, this name is used to identify the TCP server in the "Tag Setup" and "Tag View" pages.

**IP Address**

IP address of the remote Modbus TCP-IP server

**TCP Port**

Server TCP port

**Timeout (ms)**

Connection timeout / response for Modbus TCP requests, in milliseconds

**Delay between Polls (ms)**

Interval between two consecutive Modbus TCP requests, in milliseconds

**Read/Write Retries**

Maximum number of attempts for Modbus TCP requests; this always applies to write requests; for read requests, only applies to tags with "Gateway Tag Mode" = "BRIDGE".

**Multiple Read Max Number**

Maximum number of Modbus registers that can be read in a single Modbus TCP request; it is used to reduce the number of read requests sent via the TCP connection, thus optimising performance

**Multiple Write Max Number**

Maximum number of Modbus registers that can be written in a single Modbus TCP request; it is used to reduce the number of write requests sent via the TCP connection, thus optimising performance.

The maximum number of TCP-IP Modbus Servers that can be configured is 25.

**8.22. TAG SETUP PAGE (Shared Memory Tag Conf.)**

This page is used to configure tags in Modbus Shared Memory Gateway mode.

It is possible to import the inserted tags through an excel template (downloadable from the Seneca website) or export the current ones.

It is also possible to insert new tags directly from the web page, all Seneca devices are available via an internal database.

The addition of a tag has the following fields (most of them pre-compiled as defined in the database included in the product)

**Gateway Tag Name**

Tag mnemonic name

**Gateway Modbus Start Register Address**

Start address of the tag on the Shared Memory Gateway

**Target Modbus Device**

Device from which to read (or write to) the tag (if present in the database) or custom.

**Target Resource**

Represents the device resource to which the TAG is associated (e.g. Input1, Output2 etc...) only in the case other than Custom Device not present in the database.

**Target Connected To**

The serial port or Ethernet resource to which the external device is connected.

**Gateway Tag Mode**

This field defines how the tag will be handled by the gateway processes; possible values are: GATEWAY, BRIDGE, SHARED MEMORY or EMBEDDED.

The difference between Gateway and Bridge is that Bridge tags are updated only when required, in Gateway mode the tags are updated cyclically even if they are not required.

SHARED MEMORY are tags that can be written by Modbus RTU / Modbus TCP-IP or by Logical Rules and are TAGs representing local variables. This type of tag can also be used for calculated tags.

**EMBEDDED**

for integrated digital I/Os on board the device

**Gain**

This field corresponds to the value of the coefficient  $m$  in the formula

$$m * val + q$$

applied to the value "val" read by the device

**Offset**

This field corresponds to the value of the coefficient  $q$  in the formula

$$m * val + q$$

applied to the value "val" read by the device

**Initial Value**

Start value of the tag

**Error Mode**

This field defines which value is provided in the answer to a Modbus (read) request, when the value from the destination device is not available.

The possible ways are:

LAST VALUE: the last available value is given.

ERROR VALUE: the value specified in the field " ERROR VALUE " is provided.

**Error Value**

This field defines which value is given in the reply to a Modbus request (reading), when the value from the destination device is not available and the " ERROR MODE " field is set to " ERROR VALUE ".

**HTTP POST VID**

This field is used to create the "Variable ID" (VID) that identifies the tag in HTTP POST requests (useful only when HTTP POST protocol is enabled).

The VID string is given by the "V" character plus the number contained in the field

**Read Only**

If selected, the tag can only be written by an external protocol (e.g. Modbus RTU or TCP-IP) and not by a logical rule.

**Retain**

If selected, the tag is saved in a writable retention memory (feRAM), when you restart the device the last value is loaded from the memory.

This option is only available for SHARED MEMORY tags.

**Calculated Function**

Only active if Tag mode is "Shared Memory". Can be used to calculate the MIN / MAX / AVG value of a tag. Note that the calculation is only enabled if the datalogger is enabled. The averaging calculation time is given by the acquisition time.

**Export to Display/PLC**

If active, it allows the tag to be displayed on the display or virtual display (depending on whether the device is equipped with a display or not) and on the Straton PLC.

**Alarm Enabled**

This field is a read-only flag that indicates whether an alarm has been defined for the tag.

**8.23. TAG VIEW PAGE (Shared Memory Tag Conf.)**

This page displays the real time values of the configured tags.

The "Data Logger" buttons can be used for:

- start the Data Logger functionality, if it has been stopped (START);
- interrupt the Data Logger functionality, if running (STOP);
- clean the Data Logger's internal cache (this will also stop the Data Logger) (CLEAN CACHE).

The display is automatically updated.

The "ALARM" column shows the status of the alarm defined for the tag, if present; the ANALOG DANGER ALARM" column has a similar behaviour, but is only meaningful for analog tags when the "Alarm Low Low Value" and "Alarm High High Value" thresholds are defined in the alarm configuration.

It is also possible to export the datalogger files to a USB stick by pressing the "COPY TO USB" button.

If the TAG is writable the last column also includes a button that can be used to write a value to the selected tag.

**8.24. DB DEVICE CUSTOM PAGE (Shared Memory Tag Conf.)**

On this page you can manage the database of registers of external devices to connect to.

**8.25. ALARM CONFIGURATION PAGE (Alarms)**

This page displays the list of configured alarms.

By clicking on the "ADD" button, you can configure a new alarm.

**Enabled**

Flag to enable / disable an alarm

**Type**



This parameter indicates whether it is a digital or analog alarm; when changing the type, some parameters are enabled or disabled

**Name**

The name of the alarm; since this parameter is used as a key to identify the alarm, it is not possible to configure two alarms with the same name

**Tag**

The tag to which the alarm is connected.

The list of tags changes according to the type of alarm (digital or analog).

You can only associate one alarm to one tag

**Activation Delays**

This parameter defines the time interval, in seconds, during which the alarm condition must be kept true to generate the alarm

**Ignore on Boot**

This is a flag used to avoid generating the alarm, if the alarm condition is detected during system startup

**Auto Acknowledge**

This is a flag used to avoid the need for an acknowledgement (ACK) by the user to allow the alarm to be cleared when it ceases.

**Boolean Alarm Value**

For a digital alarm, this parameter indicates the value of the tag (LOW or HIGH) that corresponds to the alarm condition.

**Alarm Low Value**

For an analog alarm, this parameter defines the low alarm threshold i.e. if the tag value falls below this threshold, the alarm condition is activated

**Alarm High Value**

For an analog alarm, this parameter defines the high alarm threshold i.e. if the tag value exceeds this threshold, the alarm condition is activated

**Alarm Low Low Value**

For an analog alarm, this parameter defines the low dangerous alarm threshold, i.e. if the tag value falls below this threshold, the alarm condition is activated

**Alarm High High Value**

For an analogical alarm, this parameter defines the high dangerous alarm threshold, i.e. if the tag value exceeds this threshold, the alarm condition is activated.

**Deadband Value**

This parameter defines a range within which the alarm does not fall (hysteresis).

The possible alarm states are explained in the following table:

<b>Status</b>	<b>Level</b>	<b>Meaning</b>
None	-	The tag has never entered the alarm condition
Alarm	Alarm	The value of the digital has reached the value defined by the parameter "Boolean Alarm Level".
Alarm Low	Alarm	The analog tag has fallen below the value defined by the "Alarm Low Value" parameter
Alarm High	Alarm	The analog tag has exceeded the value defined by the "Alarm High Value" parameter
Alarm Low Low	Analog Danger Alarm	The analog tag has fallen below the value defined by the "Alarm Low Value" parameter
Alarm High High	Analog Danger Alarm	The analog tag has exceeded the value defined by the "Alarm High Value" parameter
Acknowledge	-	The alarm received ACK from the user (or was configured with Auto Acknowledge)
Return	-	The tag has exited the alarm condition, but the alarm has not been acknowledged and the alarm has the "Auto Acknowledge" parameter set to OFF
End	-	The tag has exited the alarm condition and the alarm has been acknowledged or the alarm has the "Auto Acknowledge" parameter set to ON

As already mentioned, when exiting the alarm condition the alarm states can follow two different paths, depending on the value of the " Auto Acknowledge" parameter:

- Alarm\* → Return → <ACK> → End      if "Auto Acknowledge"=OFF
- Alarm\* → End                                      if "Auto Acknowledge"=ON

## 8.26. ALARM SUMMARY PAGE (Alarms)

This page shows the alarms currently active in the system.

**Name**

Alarm name

**Tag Name**

Tag connected to the alarm

**Level**

Hazard" level of the alarm:

Alarm" value for digital alarms

Alarm" or "Analog Danger Alarm" may apply for analog alarms

**Status On**

Alarm status when triggered

**Timestamp On**

Date Time of when the alarm was triggered

**Status Action**

"None" when the alarm goes off

It can evolve into:

"Acknowledged", If the alarm has been acknowledged

"Return",if the alarm has returned but the "Auto Acknowledge" setting is OFF

**Timestamp Action**

Date Time of action (previous field)

## 8.27. ALARM HISTORY PAGE (Alarms)

This page shows all alarm status transitions that have occurred in the system, up to a maximum of 1000; alarm status transitions are shown from the most recent to the oldest.

## 8.28. SD/USB TRANSFER CONFIGURATION PAGE (CLIENT PROTOCOLS)

This page contains parameters that indicate whether log files are copied to a USB stick (in models without a micro SD card slot) or to a micro SD card and for how long they are kept.

**Enable**

Enable or disable copying of logs to USB

**Max Failure Counter**

This parameter defines the maximum number of failed copy attempts before entering the "Wait after failure" state (see next field)

**Wait After Failure (minutes)**

This parameter defines the duration, in minutes, of the "Wait after failure" status. In this state, no further attempt is made to copy a log file to the USB

**Clean Period (days)**

This parameter defines for how many days the log files must be kept on the USB; that is, after the specified number of days, the log files are deleted.

Files are saved in folders according to the following convention:

*yyyymmdd* (yyy=year, mm=month, dd=day)

example:

20180612

Each of these folders includes a subfolder:

*logX* X=[1..4], number of the group

The log file name has the following convention:

*Lmmmmmmm.csv*

where *mmmmmmm* is the number of minutes from [1/1/2000 00:00], corresponds to the date of the first log line  
example:

*L9701690.csv*

SD cards and USB sticks must be formatted with the FAT32 filesystem.



**USB STICKS OR SD CARDS ARE OFTEN FORMATTED WITH THE "EXFAT" FILESYSTEM (DEPENDING ON THE SIZE) AND MUST THEREFORE BE REFORMATTED WITH THE "FAT32" FILESYSTEM**

**8.29. FTP CONFIGURATION PAGE (CLIENT PROTOCOLS)**

This page contains parameters related to the transfer of log files to a remote FTP server.

**Enable**

Enable or not the transfer of logs via FTP

**Max Failure Counter**

This parameter defines the maximum number of failed copy attempts before entering the "Wait after failure" state (see next field)

**Wait After Failure**

This parameter defines the duration, in minutes, of the "Wait after failure" status. In this state, no further attempt is made to copy a log file to the USB

**Crypto Mode**

Defines which encryption to use for the FTP connection between:

- None
- TLS/SSL Implicit
- TLS/SSL Explicit

**Host**

Hostname (FQDN) or FTP server IP address

**Port**

TCP port of the FTP server

**Username**

Server Username

**Password**

Server password

**Path**

Directory path, on the FTP server, where the log files will be saved. It must start with the character "/".

Log files transferred via FTP will have the following format:

`<RTU_Name>_X_log<date_time>.csv`

Where:

- `<RTU_Name>` is the value of the "RTU Name" field in the "General Settings" page
- `X=[1..4]` is the number of the group
- `<date_time>` has the format `yyyymmdd` (yyyy=year, mm=month, dd=day); corresponds to the log first line date

Example:

`SENECA_1_log20180507101507.csv`

**8.30. EMAIL CONFIGURATION PAGE (CLIENT PROTOCOLS)**

Emails can be used to transfer log files or to send alarms; some parameters on this page are only used when transferring log files, not when sending alarms; these parameters are marked with the caption "Data Logger Only".

**Enable**

Flag indicating whether log files are transferred via EMAIL or not

Note that it is possible to send alarms via EMAIL even if this parameter is set to OFF.

**Max Failure Counter**

This parameter defines the maximum number of failures before entering the "Wait after failure" state (see next field).

**Wait After Failure (minutes)**

This parameter defines the duration, in minutes, of the "Wait after failure" status.

In this state, no further attempt is made to send a log file or alarm via EMAIL

**Crypto Mode**

This parameter defines the encryption type of the EMAIL connection.

The possible ways are:

None

TLS/SSL

STARTTLS

**Host**

Hostname (FQDN) or IP address of the MAIL server

**Port**

EMAIL server port (TCP)

**Username**

EMAIL server username

**Password**

EMAIL server password

**From**

Sender's email address

**To**

List of one or more e-mail recipient addresses, separated by commas.

This parameter is only used for the transfer of log files

**Subject**

Subject of the email.

This parameter is only used for the transfer of log files

**Text**

Email text: If left blank a standard text is added.

This parameter is only used for the transfer of log files

**Line Terminator**

Type of line terminator to use

Log files sent as EMAIL attachments have names with the following format:

<RTU\_Name> \_X\_log <date\_time> .csv

where:

- <RTU\_Name> is the value of the "RTU Name" parameter in the "General Settings" page
- X = [1..4] is the number of the group
- <date\_time> has the format `yyyymmdd` (yyyy = year, mm = month, dd = day); this is the timestamp of the first sample (line) in the log file

for example..:

SENECA\_1\_log20180507101507.csv

Emails containing alerts have the following text format:

MESSAGE: <timestamp>

<nome rtu> <testo messaggio>

with the following object:

<nome rtu>: ALARM

Sending alarm messages is managed by the "Rule Management" section.

### 8.31. HTTP CONFIGURATION (CLIENT PROTOCOLS)

The http post protocol can be used to send log samples or alarms (events) to an HTTP server.

**Enable**

Enable or not the sending of logs via http

**Max Failure Counter**

This parameter defines the maximum number of failures before entering the "Wait after failure" state (see next field).

**Wait After Failure (minutes)**

This parameter defines the duration, in minutes, of the "Wait after failure" status. In this state, no further attempt is made to send a log file or alarm via http POST.

**SSL/TLS**

This parameter defines whether or not to enable HTTP connection encryption.

**Host**

Hostname (FQDN) or HTTP server IP address

**Port**

TCP port of the HTTP server

**Seneca Protocol**

If enabled, it allows HTTP sending with the typical parameters of the Seneca protocol (used on Cloud Box)

**Authentication**

Allows you to enable or disable user/password authentication

**Username**

HTTP server username

**Password**

HTTP server password

**Path**

Adds a PATH string

**Url**

Allows you to view the publication string

You can also refer to the specific document of the http protocol used

## 8.32. MQTT CONFIGURATION (CLIENT PROTOCOLS)

The MQTT protocol can be used to send (and receive) data or events to a cloud server (called a broker).

**Enable**

Enable or not the MQTT protocol.



**Max Failure Counter**

This parameter defines the maximum number of failures before entering the "Wait after failure" state (see next field).

**Wait After Failure (minutes)**

This parameter defines the duration, in minutes, of the "Wait after failure" status. In this state, no further attempts are made to send or receive data via MQTT.

**Client ID**

Defines the Client ID used in the MQTT protocol

**Broker Host**

Defines the host name of the MQTT broker

**Broker Port**

Defines the MQTT broker port

**Use WebSockets**

Allows you to activate MQTT communication via Websockets

**Keep Alive Interval (seconds)**

This parameter defines Keep alive which ensures that the connection between the broker and client is still open and that the broker and client are aware that they are connected. When the client establishes a connection to the broker, it tells the broker a time interval in seconds. This interval defines the maximum period of time during which the broker and client may not communicate with each other.

**Clean Session**

This parameter defines the "clean session".

When the clean session flag is set to true, the client does not want a persistent session. If the client disconnects for any reason, all information and messages queued from a previous session are lost.

**Message Retain**

Usually if a publisher publishes a message on a topic to which no one is subscribed, the message is simply discarded by the broker. However, the publisher can tell the broker to keep the last message of that topic.

**Quality of service**

This parameter defines the QOS of the MQTT protocol.

Can be selected from

QOS 0 (once only, without ack)

QOS 1 (at least once, with ack)

QOS 2 (once only, with ack and resend)

**Authentication**

This parameter defines whether user/password authentication should be used to access the broker

**Username**

Broker Username

**Password**

Broker password

**SSL/TLS**

Defines if the crypto is SSL/TLS

**Log on Change**

This parameter defines whether topics should only be sent in case of change (based on minimum time) or not.

**Publish with multiple tags**

This parameter defines whether the publish contains multiple tags or whether the device should send a publish for each tag

**Publish Topic for Logs**

Selects the topic name for the logs using the following table:

%c	Device Client ID
%m	Device MAC Address
%M	Device MAC Address (without ':')
%e	Device IMEI
%d	Date/Time
%t	timestamp (number of seconds from 01/01/1970)
%x	text (only for "Publish Payload for Alarms")
%b	bulk (format specified in "Publish Bulk Format")
%n	Tag name (only for "Publish Bulk Format")
%v	Tag value (only in "Publish Bulk Format")
%i	Tag validity flag (only in "Publish Bulk Format")
%f	Tag id with progressive number (only in "Publish Bulk Format")
%j[field]	Adds double quotes " to [field]. The double quotes represent a string in JSON
;%\$tag_name\$	Value of the "tag_name" tag
;%#tag_name#	Validity of the "tag_name" tag

%u	Timestamp in [ms] (only in "Publish Fast Log Sample" and "Publish Bulk Format")
%p	Sampling period (only in "Publish Fast Log Sample")
%w	Format (only in "Publish Fast Log")

### **Publish Payload for Logs**

Selects the format to be used for the payload in Json format using the following table:

%c	Device Client ID
%m	Device MAC Address
%M	Device MAC Address (without ':')
%e	Device IMEI
%d	Date/Time
%t	timestamp (number of seconds from 01/01/1970)
%x	text (only for "Publish Payload for Alarms")
%b	bulk (format specified in "Publish Bulk Format")
%n	Tag name (only for "Publish Bulk Format")
%v	Tag value (only in "Publish Bulk Format")
%i	Tag validity flag (only in "Publish Bulk Format")
%f	Tag id with progressive number (only in "Publish Bulk Format")
%j[field]	Adds double quotes " to [field]. The double quotes represent a string in JSON
\$\$tag_name\$	Value of the "tag_name" tag
##tag_name#	Validity of the "tag_name" tag
%u	Timestamp in [ms] (only in "Publish Fast Log Sample" and "Publish Bulk Format")
%p	Sampling period (only in "Publish Fast Log Sample")
%w	Format (only in "Publish Fast Log")

### **Publish Bulk Format**

Selects the format for "bulk mode" according to the following table:

%c	Device Client ID
%m	Device MAC Address
%M	Device MAC Address (without ':')

%e	Device IMEI
%d	Date/Time
%t	timestamp (number of seconds from 01/01/1970)
%x	text (only for "Publish Payload for Alarms")
%b	bulk (format specified in "Publish Bulk Format")
%n	Tag name (only for "Publish Bulk Format")
%v	Tag value (only in "Publish Bulk Format")
%i	Tag validity flag (only in "Publish Bulk Format")
%f	Tag id with progressive number (only in "Publish Bulk Format")
%j[field]	Adds double quotes " to [field]. The double quotes represent a string in JSON
;%tag_name\$	Value of the "tag_name" tag
;%#tag_name#	Validity of the "tag_name" tag
%u	Timestamp in [ms] (only in "Publish Fast Log Sample" and "Publish Bulk Format")
%p	Sampling period (only in "Publish Fast Log Sample")
%w	Format (only in "Publish Fast Log")

### **Publish Bulk Format for Fast Logging**

Selects the format for the "bulk mode" for the fast logging data according to the following table:

%c	Device Client ID
%m	Device MAC Address
%M	Device MAC Address (without ':')
%e	Device IMEI
%d	Date/Time
%t	timestamp (number of seconds from 01/01/1970)
%x	text (only for "Publish Payload for Alarms")
%b	bulk (format specified in "Publish Bulk Format")
%n	Tag name (only for "Publish Bulk Format")
%v	Tag value (only in "Publish Bulk Format")
%i	Tag validity flag (only in "Publish Bulk Format")
%f	Tag id with progressive number (only in "Publish Bulk Format")

%j[field]	Adds double quotes " to [field]. The double quotes represent a string in JSON
;%\$tag_name\$	Value of the "tag_name" tag
;%#tag_name#	Validity of the "tag_name" tag
%u	Timestamp in [ms] (only in "Publish Fast Log Sample" and "Publish Bulk Format")
%p	Sampling period (only in "Publish Fast Log Sample")
%w	Format (only in "Publish Fast Log")

### **Publish Topic for Alarms**

Selects the format for topic names in alarms according to the following table:

%c	Device Client ID
%m	Device MAC Address
%M	Device MAC Address (without ':')
%e	Device IMEI
%d	Date/Time
%t	timestamp (number of seconds from 01/01/1970)
%x	text (only for "Publish Payload for Alarms")
%b	bulk (format specified in "Publish Bulk Format")
%n	Tag name (only for "Publish Bulk Format")
%v	Tag value (only in "Publish Bulk Format")
%i	Tag validity flag (only in "Publish Bulk Format")
%f	Tag id with progressive number (only in "Publish Bulk Format")
%j[field]	Adds double quotes " to [field]. The double quotes represent a string in JSON
;%\$tag_name\$	Value of the "tag_name" tag
;%#tag_name#	Validity of the "tag_name" tag
%u	Timestamp in [ms] (only in "Publish Fast Log Sample" and "Publish Bulk Format")
%p	Sampling period (only in "Publish Fast Log Sample")
%w	Format (only in "Publish Fast Log")

### **Subscribe Topic**

Selects the Topic Subscribe according to the following table:

%c	Device Client ID
----	------------------

%m	Device MAC Address
%M	Device MAC Address (without ':')
%e	Device IMEI
%d	Date/Time
%t	timestamp (number of seconds from 01/01/1970)
%x	text (only for "Publish Payload for Alarms")
%b	bulk (format specified in "Publish Bulk Format")
%n	Tag name (only for "Publish Bulk Format")
%v	Tag value (only in "Publish Bulk Format")
%i	Tag validity flag (only in "Publish Bulk Format")
%f	Tag id with progressive number (only in "Publish Bulk Format")
%j[field]	Adds double quotes " to [field]. The double quotes represent a string in JSON
%%\$tag_name\$	Value of the "tag_name" tag
%%#tag_name#	Validity of the "tag_name" tag
%u	Timestamp in [ms] (only in "Publish Fast Log Sample" and "Publish Bulk Format")
%p	Sampling period (only in "Publish Fast Log Sample")
%w	Format (only in "Publish Fast Log")

### **LWT Topic**

Selects the "Last Weel and Testament" topic according to the following table:

%c	Device Client ID
%m	Device MAC Address
%M	Device MAC Address (without ':')
%e	Device IMEI
%d	Date/Time
%t	timestamp (number of seconds from 01/01/1970)
%x	text (only for "Publish Payload for Alarms")
%b	bulk (format specified in "Publish Bulk Format")
%n	Tag name (only for "Publish Bulk Format")
%v	Tag value (only in "Publish Bulk Format")
%i	Tag validity flag (only in "Publish Bulk Format")

%f	Tag id with progressive number (only in "Publish Bulk Format")
%j[field]	Adds double quotes " to [field]. The double quotes represent a string in JSON
%%\$tag_name\$	Value of the "tag_name" tag
%%#tag_name#	Validity of the "tag_name" tag
%u	Timestamp in [ms] (only in "Publish Fast Log Sample" and "Publish Bulk Format")
%p	Sampling period (only in "Publish Fast Log Sample")
%w	Format (only in "Publish Fast Log")

### **LWT Payload**

Selects the Payload text of "Last Weel and Testament"

### **Save Configuration URL**

This is the URL for the "Save Configuration" command received from mqtt (see the chapter on sending commands from the cloud in this manual)

### **Load Configuration URL**

This is the URL for the "Load Configuration" command received from mqtt (see the chapter on sending commands from the cloud in this manual)

### **FW Update URL**

This is the URL for the "FW Update" command received from mqtt (see the chapter on sending commands from the cloud in this manual)

### **Sleep Timeout**

MQTT task wake-up time, the shorter it is, the more responsive MQTT is (at the expense of higher CPU load).

### **MQTT Certificates**

It is used to manage the certificates necessary for the TLS connection.

## **8.33. PHONEBOOK PAGE (LOGIC CONFIGURATION)**

This page is used to configure the address book for sending text messages by the device via email and/or (on models equipped with a modem) SMS.

### **User Type**

It is possible to define three different account profiles:

#### *Admin*

This account receives alarms via SMS or EMAIL from any group.

This account can send SMS commands to the device, It also receives all rejected or unrecognised SMS commands (if the "SMS Relay to Admin" parameter is set to ON and all "Startup SMS" messages if the "Startup SMS" parameter is set to ON).

#### *Manager*

This account receives alarms via SMS or EMAIL from the group to which it belongs.

This account can send SMS commands to the device.

#### *User*

This account receives alarms via SMS or EMAIL from the group to which it belongs.

At the time of compilation, the group(s) to which the account belongs is required, so you can divide the text alerts between the various accounts.

Note how "Admin" accounts receive alarms from any group.

### **8.34. MESSAGE CONFIGURATION PAGE (LOGIC CONFIGURATION)**

In this section it is possible define the text messages related to the alarms that the device must manage.

The message text can only contain ASCII characters.

It is possible to use the {TAG\_NAME} syntax to include the current value of a tag in the text.

For example the message text:

"WATER LEVEL = {LEVEL} m"

Will provide a text with the tag value as text, if the tag "LEVEL" is 1.232 you will have:

WATER LEVEL = 1.232 m

This syntax can be used more than once in a message text.

Each message has an ID field which is used to associate the message with the alarm in the logical rules.

### **8.35. TIMER CONFIGURATION PAGE (LOGIC CONFIGURATION)**

This section allows you to define up to 100 timers to be used in logic rules.

The ID represents the mnemonic of the timer that must be used in the rules.

"Enable" selects whether the timer is active or not.

"Duration" is the activation value in [ms].



**Note**

The timers are in stop mode by default, they need an action to start and an action to restore, according to the following scheme:

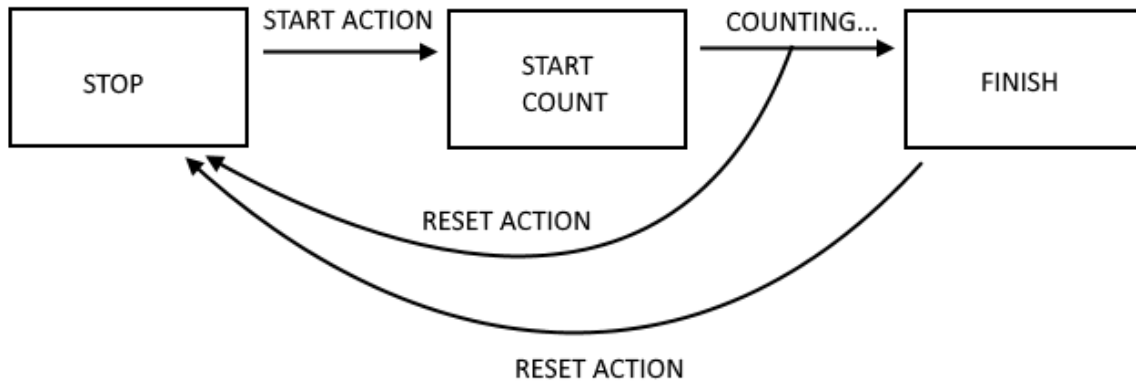

**8.36. RULE SCRIPTS PAGE (LOGIC CONFIGURATION)**

On this page you can upload files related to scripts to be executed as actions of logical rules. The extension for the type of script to be used must be respected:

<b>Script type</b>	<b>Extension</b>
Linux Shell	“.sh”
PHP	“.php”
Python	“.py”
Binary	“.bin”

You can upload a maximum of 100 Kbyte file.

**8.37. RULE MANAGEMENT PAGE (LOGIC CONFIGURATION)**

In this section you can define a set of logical rules that will implement a program. To configure a rule, the following parameters are available:

**8.37.1. RULE CONFIGURATION**

**Enabled**

Indicates whether the rule is enabled or should be excluded from execution

**Index**

Rule execution order (1 = First rule to be executed)

**Description**

Mnemonic textual description of the rule

**Period [ms]**

If the value is = 0, actions are executed only if there is a change in the result of the "OR / AND" (i.e. on change of state).

If the value is different from 0 ms the actions are performed trying to respect the inserted timing.



**ATTENTION!**

**Use appropriate period values for EMAIL / SMS / http / MQTT sending actions!**

**NOTE:**

If Period is > 0 the actions are always performed in "repeat" mode

**8.37.2.IF CONDITION: TYPE**

This section defines the type of condition, the following types are possible:

**None**

No conditions to be assessed

**Alarm State**

The condition refers to the state of an alarm, the following parameters are possible:

<i>Field</i>	<i>Meaning</i>
Alarm Name	Selects the alarm from the list of all configured alarms
Alarm State	Alarm status. Possible states are: None Alarm (digital only) Alarm Low Low (analog only) Alarm Low (analog only) Alarm High (analog only) Alarm High High (analog only) Acknowledge Return End

	Depending on the type (digital or analog) of the selected alarm, some states are disabled
Analog Danger Alarm	Flag indicating whether the alarm level must be "Analog Danger" or not, applies only to alarms on analog tags

### Alarm Active

The alarm condition refers to the Active or No state of an alarm, the following parameters are possible:

<i>Field</i>	<i>Meaning</i>
Alarm Name	Selects the alarm from the list of all configured alarms
Alarm Active	<p>Indicates whether or not the alarm should be active.</p> <p>The alarm is active if it is in one of these states:</p> <ul style="list-style-type: none"> <li>Alarm (only for digital tags)</li> <li>Alarm Low Low (only for analog tags)</li> <li>Alarm Low (only for analog tags)</li> <li>Alarm High (only for analog tags)</li> <li>Alarm High High (only for analog tags)</li> <li>Acknowledge</li> </ul> <p>The alarm is not active if it is in one of the following states:</p> <ul style="list-style-type: none"> <li>None</li> <li>Return</li> <li>End</li> </ul>
Analog Danger Alarm	Flag indicating whether the alarm level should be "Analog Danger" or not, significant only for analog alarms.

### Always

The If condition is always true.

Note that the rule is only executed once if Period is = 0 ms or if the actions are in one time mode.

If you need to execute a rule at each cycle, you need to put the actions in "repeat mode".

If you need to run a rule over time (every x ms), you must set Period > 0ms.

### Digital Tag

The condition depends on the state of a digital tag:

<i>Field</i>	<i>Meaning</i>
Tag	Selects the tag to be used for the condition
Operator	Only "=" may apply

Tag / Constant value	Selects whether the comparison is between another digital tag or a constant boolean value (TRUE or FALSE)
----------------------	---

### Analog Tag

The condition depends on a comparison with an analog TAG

<b>Field</b>	<b>Meaning</b>
Tag	Selects the tag to be used for the condition
Operator	It may be: “=” “>” “<” “>=” “<=”
Tag / Constant value	Selects whether the comparison is between another analog tag or a constant value

### Timer

The condition depends on the state of the selected timer

<b>Field</b>	<b>Meaning</b>
ID	Selects the timer ID to use
Expired	It can be: "OFF" or "ON" With "ON" the condition is only true when the timer expires (FINISH status). With "OFF" the condition is true until the timer is in STOP or COUNTING. When the timer is in FINISH state the condition becomes false.

The operation of the Timer is shown in the following diagram:

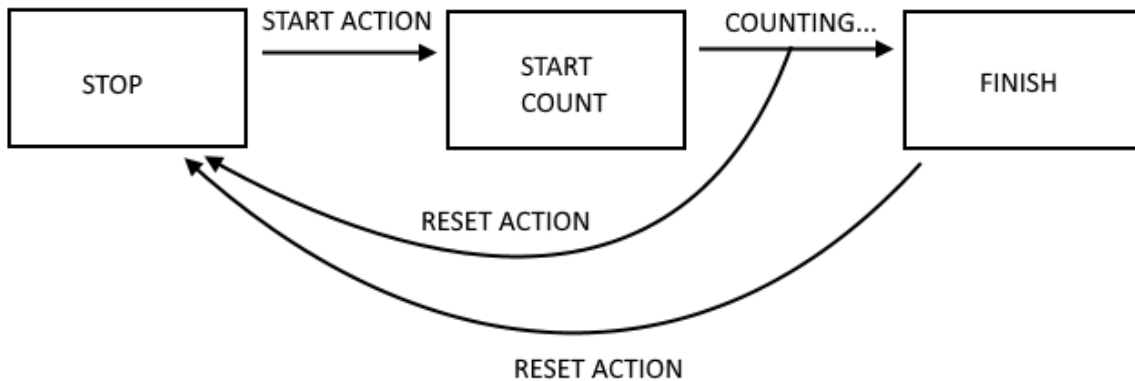

### Scheduler

The condition depends on the set scheduler (calendar):

<b>Field</b>	<b>Meaning</b>
Type	It may be: Daily, Weekly Monthly Daily: the condition is true every day at the configured hour and minute Weekly: the condition is true on the selected day of the week at the selected hour and minute Monthly: the condition is true on the selected day of the month at the selected hour and minute
Day	If the type is Weekly sets the day of the week: 0 = Sunday 1 = Monday 2 = Tuesday 3 = Wednesday 4 = Thursday 5 = Friday 6 = Saturday If the type is Monthly: Selects the day of the month from 1 to 31
Hour	Hours
Minute	Minutes



**Rule Status**

The condition depends on whether a rule is enabled or not:

<b>Field</b>	<b>Meaning</b>
ID	Selects the rule ID
Enabled	Selects between "enabled" or "disabled" If "Enabled" the condition is REAL if the selected rule is enabled. If "Disabled" the condition is REAL if the selected rule is disabled.

**Bitmask**

The condition depends on masking a tag with a hexadecimal constant:

<b>Field</b>	<b>Meaning</b>
Tag	Selects the tag to apply the bitmask to from a list containing all tags with data type "16Bit Unsigned"
Mask	The bit mask represented as a string of 4 hexadecimal digits

The "Bit mask" condition is TRUE if the AND operation bit by bit between the Tag and the Data Mask is different from 0; FALSE otherwise.

*Example:*

*Tag=0x1233 (hexadecimal) = 0b 0001 0010 0011 0011 (binary)*

*Mask=0x8001 (hexadecimal) = 0b 1000 0000 0000 0001 (binary)*

*It means that the mask analyses bit 0 (least significant) and bit 15 (most significant) of the Tag.*

*The AND bit by bit provides:*

*0001 0010 0011 0011*

*1000 0000 0000 0001*

*-----*

*0000 0000 0000 0001*

*So the condition is TRUE.*

8.37.3.IF CONDITION OPERATOR

The "IF conditions" can be combined together in "OR" or "AND" logic, in practice:

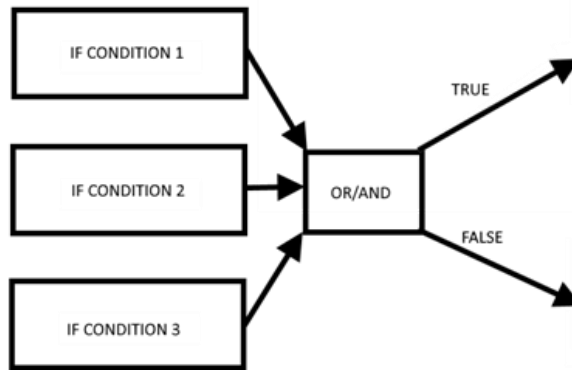

The "IF conditions" linked together by "OR" go to the TRUE state if at least one of the conditions is true.  
 The "IF conditions" linked together by "AND" only go to the TRUE state if all of them are true.

More details are given in the following table:

IF CONDITION 1	IF CONDITION 2	IF CONDITION 3	"OR"	"AND"
FALSE	FALSE	FALSE	FALSE	FALSE
FALSE	FALSE	TRUE	TRUE	FALSE
FALSE	TRUE	FALSE	TRUE	FALSE
FALSE	TRUE	TRUE	TRUE	FALSE
TRUE	FALSE	FALSE	TRUE	FALSE
TRUE	FALSE	TRUE	TRUE	FALSE
TRUE	TRUE	FALSE	TRUE	FALSE
TRUE	TRUE	TRUE	TRUE	TRUE

8.37.4.THEN/ELSE ACTION

In this section you can define the action that must be performed if the conditions result in TRUE (THEN action) or FALSE (ELSE action).

**NONE**

No action to take

**Send Alarm SMS**

**Send Alarm EMAIL**

**Send Alarm HTTP POST**



**Send Alarm MQTT**

They allow you to send a text message (defined in the messages section) through the available client protocols

<i>Field</i>	<i>Meaning</i>
Message	Selects the text message to send from those configured
Group	Selects the sending group (only for SMS and EMAIL)

**Digital Tag**

Performs a write to a digital tag.

<i>Field</i>	<i>Meaning</i>
Action Mode	Allows you to select between "One Time" or "Repeat".  With "One Time" the action is executed only if there is a change in the result of the OR / AND conditions.  With "Repeat" the action is executed at every loop (if the rule is enabled and if there is no configured period).
Destination Tag	This is the tag where the calculated TRUE/FALSE result is copied
Operator	This is the Boolean operator to use, selected from =, NOT, OR etc ...
Source Tag 1 / Constant value 1	Selects the first tag to use in the boolean calculation. It is also possible to use a boolean constant
Source Tag 2 / Constant value 2	Select the second Tag if the operator needs 2 inputs (For example operator "OR"). It is also possible to use a boolean constant

**Analog Tag**

Performs a write to an analog type Tag.

<i>Field</i>	<i>Meaning</i>
Action Mode	Select from "One Time" or "Repeat".  With "One Time" the action is executed only if there is a change in the result of the OR / AND conditions.  With "Repeat" actions are performed at each loop (if the rule is enabled and there is no configured period).
Destination Tag	This is the tag where the calculated result is copied to
Operator	It is the mathematical operator to use, you can select from: "=" copies the source tag 1 or the constant value 1 to the destination tag

	<p>Example: Destination tag = Origin tag 1 Or Target tag = constant value 1</p> <p>"+" = Add the value of the source tag1 or the constant value 1 to the target tag and copy the result to the target tag.</p> <p>Example: Destination tag = Destination tag + Origin tag 1</p> <p>"-" = Subtracts the value of the source tag1 from the target tag and copies the result to the target tag.</p> <p>Example: Destination tag = Destination tag - Origin tag 1</p> <p>"*" = Multiply the target tag by the value of source tag 1 and copy the result to the target tag.</p> <p>Example: Destination tag = Destination tag * Origin tag 1</p> <p>"/" = Splits the target tag with the source tag value 1 and copies the result to the target tag.</p> <p>Example: Destination tag = Destination tag / Origin tag 1</p> <p>"%" = Calculates the rest of the division from the target tag and the value of the source tag1 and copies the result to the target tag. (Note that 53% 7 = 4)</p> <p>Example: Destination tag = Destination tag% Source tag1</p> <p>"abs" Calculates the absolute value of Source Tag 1 or Constant value 1 and copies the result to the Destination Tag (Note that abs (-4) = 4)</p>
--	---

	<p style="text-align: center;">Example: Target tag = abs (Source tag 1)</p> <p style="text-align: center;"><b>"Sqrt"</b> Calculates the square root value of source tag 1 or constant value 1 and copies the result to the target tag. (Note that sqrt (9) = <math>\sqrt{9} = 3</math>) Example: Destination tag = sqrt (origin tag 1)</p> <p style="text-align: center;"><b>"Sqr"</b> Calculates the square value of the source tag 1 or constant value 1 and copies the result to the target tag. (Note that sqr (3) = <math>3^2 = 9</math>) Example: Destination tag = sqr (origin tag 1)</p> <p style="text-align: center;"><b>"Log"</b> Calculates the decimal logarithm of source tag 1 or constant value 1 and copies the result to the target tag. (Note that log (3) = 0.4771212) Example: Destination tag = log (origin tag 1)</p> <p style="text-align: center;"><b>"Ln"</b> Calculates the natural logarithm of the source tag 1 or constant value 1 and copies the result to the target tag. (Note that ln (3) = 1.09861228867) Example: Target tag = ln (Source tag 1)</p> <p style="text-align: center;"><b>"Exp"</b> Calculate the number of Euler elevated to Source Tag 1 or Constant value 1 and copy the result to the Destination Tag.</p> <p style="text-align: center;">Please note that: ln (exp 3) = 3 Example: Destination tag = expiration (origin tag 1)</p> <p style="text-align: center;"><b>"+"</b></p>
--	--

	<p>Adds Source Tag 1 or Constant value 1 to the value of Source Tag 2 or Constant value 2 and copies the result to the Destination Tag.  Example:  Target tag = Source tag 1+ Source tag 2</p> <p style="text-align: center;">"+"</p> <p>Subtracts the source tag 1 or constant value 1 with the value of source tag 2 or constant value 2 and copies the result to the target tag.  Example:  Destination tag = Origin tag 1- Origin tag 2</p> <p style="text-align: center;">"-"</p> <p>Multiply the source tag 1 or constant value 1 with the source tag 2 or constant value 2 and copy the result to the target tag.  Example:  Target tag = Source tag 1 * Source tag 2</p> <p style="text-align: center;">"*"</p> <p>Splits the source tag 1 or constant value 1 with the source tag 2 or constant value 2 and copies the result to the target tag.  Example:  Target Tag = Source Tag 1 / Source Tag 2</p> <p style="text-align: center;">"/"</p> <p>Calculates the rest of the division between source tag 1 or constant value 1 and source tag 2 or constant value 2 and copies the result to the target tag.  (Note that 53% 7 = 4)</p> <p style="text-align: center;">"%"</p> <p>Example:  Target tag = Source tag 1% Source tag 2</p> <p style="text-align: center;">"Pow"</p> <p>Calculates the Source Tag1 or Constant value 1 elevated to the power of the Source Tag2 / Constant value 2 and copies the result to the destination tag.  Example:  Target tag = (Source Tag1) ^ (Source Tag2)</p>
Source Tag 1 / Constant value 1	Selects the tag to be used as input 1 for the operator used. You can also use a constant value.

Source Tag 2 / Constant value 2	Selects the Tag to use as input 2 in the calculation if the operator needs 2 inputs. A constant value can also be used
---------------------------------	---

### Timer

It is possible to select the action to be performed in the selected timer

<i>Field</i>	<i>Meaning</i>
Id	Selects the timer from those configured
Action	Selects the type of action to perform on the selected timer.  "Start" performs the start action on the selected timer "Reset" performs the reset action on the timer to the stop state

### Rule Status

The action enables or disables a rule.

<i>Field</i>	<i>Meaning</i>
Id	Selects the rule
Enable	Selects whether or not the action should enable the selected rule:  "OFF" disables the selected rule "ON" enables the selected rule

### Datalogger

The action allows you to start or stop the data logger, it is also possible to select the log group to check.

<i>Field</i>	<i>Meaning</i>
Group	Selects the data logger group to monitor
Enable	Selects whether or not the action should enable the data logger  "OFF" disables the data logger for the selected group "ON" enables the data logger for the selected group

### Network

These are actions that allow you to act on the status of the VPN (enable or disable it) or the modem.

<b>Field</b>	<b>Meaning</b>
Feature	<p>Allows you to choose which element to perform the ON/OFF action on It is possible to choose between:</p> <p>PPP refers to the mobile modem data connection (if any) VPN refers to the VPN connection Firewall refers to the system firewall OpenVPN refers to the standard OpenVPN connection</p>
Start	You can choose the action to be performed between "ON" and "OFF".

### Set Bits

This action allows you to set a configurable number of bits of a given tag to the value 1 or to the value 0.

<b>Field</b>	<b>Meaning</b>
Action Mode	<p>Selects from "One Time" or "Repeat".</p> <p>With "One Time" the action is executed only if there is a change in the result of the OR / AND conditions.</p> <p>With "Repeat" the action is executed at every loop (if the rule is enabled and if there is no configured period).</p>
Destination Tag	It is the tag in which the result of the action is copied, the tag must be of type "16 bit unsigned"
Source Tag	<p>Selects the tag to use in the calculation.</p> <p>It is also possible to insert the same source tag and destination tag in order to perform the action on the same TAG.</p> <p>The tag must be of the "16 bit unsigned" type</p>
Mask	It is the mask in hexadecimal format that allows the masking of the bits to be controlled.
Action	You can choose between "Set" or set the bits to 1, or "Reset" or set the bits to 0.

### Data Logger Trigger

Allows the acquisition of a single sample in groups configured as Trigger or Periodic and Trigger. In the case of a group configured with fast logging, it starts the acquisition of max 1000 samples.

<b>Field</b>	<b>Meaning</b>
Group	Allows you to select on which log group to execute the action
Source	<p>This is a label that is saved on the data logger in order to discriminate the source of the trigger.</p> <p>the "Source" field can assume the values from "A" to "H".</p>

	<p>If the “Data Logger Trigger” action is executed in multiple rules, when different conditions occur, by setting distinct values of “Source” you can discriminate which condition generated the trigger.</p>
--	---

### Data Logger Send

The action allows the log file to be closed, preparing it for sending via the configured client protocols (valid for protocols that work with files: FTP, EMAIL and SD/USB). It should be used on groups configured with “trigger” sample mode.

<i>Field</i>	<i>Meaning</i>
Group	Selects on which group(s) to execute the action

### Data Logger Trigger Stop (fast logging)

The action allows you to stop the acquisition set with fast logging before the acquisition stops automatically once 1000 samples are reached.

The start of the fast logging acquisition is given by the data logger trigger action, if it is not stopped by this action the fast logging samples 1000 values and then stops automatically.

<i>Field</i>	<i>Meaning</i>
Group	Selects on which group(s) to execute the action

### Script Execution

The action allows you to execute a user-defined script. To upload script files to the device, the “Rules Scripts” page is provided.

<i>Field</i>	<i>Meaning</i>
Type	<p>Selects the type of script among:</p> <p>Linux Shell Allows you to run a bash script. Required file extension “.sh”</p> <p>Php Allows you to run a PHP script. Required file extension “. php”. The file must comply with PHP revision 7.3.9</p> <p>Python Allows you to run a Python script. Required file extension “. py”. The file must comply with Python rev 3.7</p> <p>Binary program Allows you to run an executable program. Extension required for the file “.bin”.</p>

	<p>The file must be compliant with the 32-bit arm v7 version.</p> <p>In scripts, you can access the Tags through a syntax explained in the relevant chapter of the following manual.</p>
File	Allows you to select the script file from those loaded on the device.
Asynchronous	<p>Allows you to select between:</p> <p><b>OFF</b> The script is executed in synchronous mode, i.e. the execution of subsequent rules is blocked until the end of the script execution.</p> <p><b>ON</b> The script is executed in asynchronous mode, i.e. the execution of subsequent rules is not blocked by the script execution.</p>

### 8.38. GENERAL SETTINGS PAGE (DATALOGGER)

This section allows to define the general parameters of the datalogger, in particular to edit how the content of the logs will look like.

The datalogger works with the following protocols:

- Via copy to USB/SD card
- EMAIL sending
- FTP sending
- Post http (if active only for group 1)
- MQTT sending

#### **RTU Name**

It is the name of the RTU, it appears in the file name in the protocols that send files (Mail and FTP).

#### **Transfer Priority**

Allows you to select whether the newest or oldest logs should be sent first.

#### **CSV Separator**

Allows you to set the separator in the csv type file between “,” “;” or “.”. It is used only in protocols that send files (Mail and FTP).

#### **Decimal Separator**

Allows you to select the decimal separator in values between “,” or “.”



***Floating Point Precision***

Allows you to select the precision with which floating point TAGs are sent between: Automatic, No decimal places or from 1 to 10 digits.

***Index Column***

Allows you to add an INDEX column to the file with the line number, it is used only in protocols that send files (Mail and FTP).

***Type Column***

Allows you to add a column to the file with the TYPE field. If the log is of the periodic type then the word "LOG" will always appear, if the log is of the periodic and trigger type then the word SYNC (in the case of a line due to the sampling time) ASYNC (in the case of a sampling line due to a trigger).appears It is used only in protocols that send files (Mail and FTP).

***Trigger Column***

Allows you to add a column to the file with the TRIGGER field. If the log is of the periodic and trigger type, the source that generated the trigger A, B, .. is indicated (see logical rules). It is used only in protocols that send files (Mail and FTP).

***Timestamp Format***

Allows you to set the date and time format in the log. It is used only in protocols that send files (Mail and FTP). In the MQTT protocol, you can choose the timestamp format using the % placeholders.

***Send Data logs via http Post***

If set to "ON" it automatically activates the enablement on the http configuration page and disables all log groups, allowing a possible manual enablement of the first group only.

***http Post Tag limitations***

Limit the sending of the http post to the first 150 TAGS to avoid overloading the http server.

**8.39. GROUP CONFIGURATION PAGE**

Here it is possible to select which of the 4 log groups should be activated and the type of log to be made.

It is possible to set a group "disabled".

It is possible to activate the following datalogger modes for each of the 4 groups:

Field	Meaning
Sampling Mode	Disabled" the group is disabled. "Periodic: All configured tags are acquired with the set time "Periodic and trigger" All configured tags are acquired with the set time and on trigger action.

	<p>“Trigger” All configured tags are acquired on trigger action.</p> <p>The trigger action can be configured in the logical rules (when a certain series of conditions are fulfilled, the trigger action is executed and the tags are forced to be acquired).</p>
Sampling Period (s)	This parameter defines the sampling period, in seconds.
Transfer Period (min)	This parameter defines the transfer period, in minutes; i.e. each time interval defined by this parameter the log file is closed and transferred.

Time before overflow provides an indication of how much time will pass before unsent data will be overwritten.

### 8.40. CLOUD CONFIGURATION PAGE

This page allows you to set the MQTT configuration automatically for the various clouds managed by the device.

Currently, you can configure:

**Generic:** Through the device's MQTT configurability, it is possible to connect to virtually any cloud

**Cumulocity:** Sets up the device to connect to the Cumulocity cloud

**Direl ADM:** Sets up the device to connect to the Direl ADM cloud

**On-Board:** Sets up the device to connect to the On-Board cloud

To add other clouds to the list, you can make a request to Seneca.

#### 8.40.1.CUMULOCITY

The Cumulocity cloud is available at:

<https://cumulocity.com/>



Seneca devices have passed cumulocity certification tests:

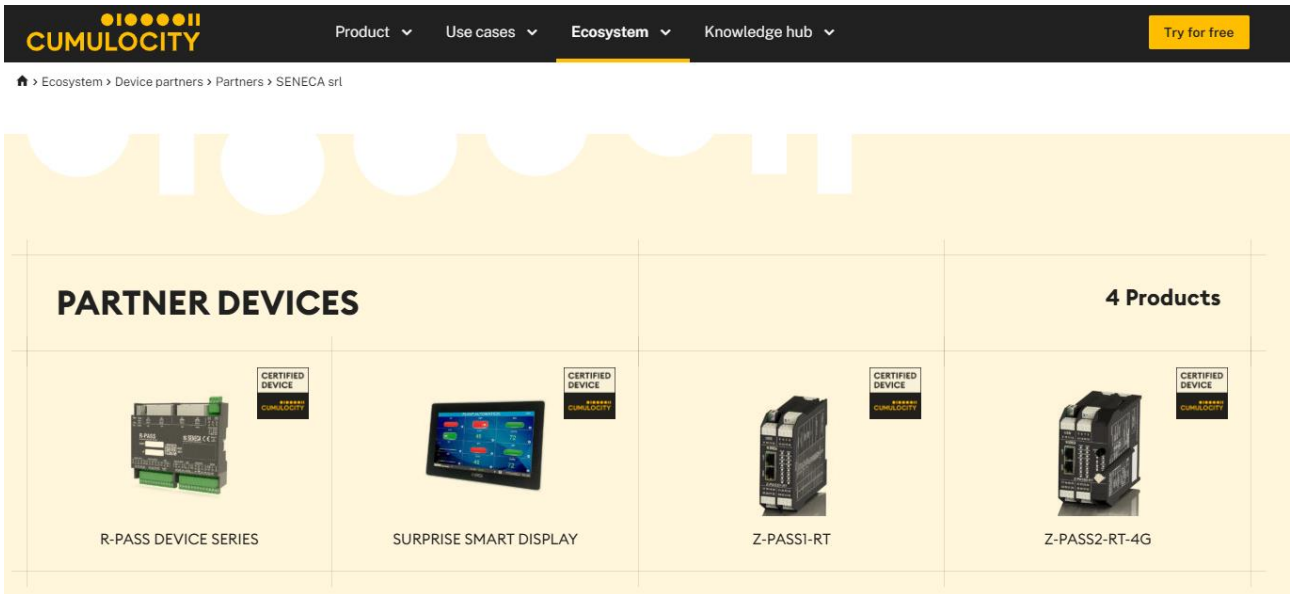

The parameters to be configured are:

Field	Meaning
Enable	Enables or disables connection to the cumulocity cloud
URL	This is the URL where the cloud registration is done
Tenant ID	It is an ID provided by the cumulocity cloud
Username	This is the username for accessing the cloud
Password	This is the password for accessing the cloud

#### 8.40.2.DIREL ADM4.0

The parameters for the Direl cloud ( <https://www.direl.it/> ) are as follows:

Field	Meaning
Enable	Enables or disables the connection to the Direl ADM4.0 cloud
Username for Commands	This is the username for writing access from the cloud to the device
Password for Commands	It is the password for writing access from the cloud to the device

8.40.3.ONBOARD

Onboard is the cloud of innovation system s.r.l., for more information refer to the site:

<https://www.onsystem-iot.com/onboard>



The parameters for the connection are:

Field	Meaning
Enable	Enables or disables the connection to the Onboard cloud
Username	This is the username for accessing the cloud
Password	This is the password for accessing the cloud

8.41. METER-BUS (M-BUS) PROTOCOL

The MBUS protocol is available only if the Straton PLC is active.

To connect to an M-Bus fieldbus it is necessary to carry out the following steps:

- 1) connect the optional RS232-MBUS Seneca “Z-MBUS” adapter to the COM1 serial port;
- 2) setting the COM1 mode to M-BUS.

The following resources are available to manage M-Bus devices:

- the web pages of the "M-Bus" section.
- the MBUS\_READ\_CTL function
- the MBUS\_WRITE\_RAW function block

The M-BUS web pages allow you to scan the bus, search for devices, detect their primary or secondary addresses; it also allows you to read data records and slave information from a device and create configuration files for import into the Straton PLC.

The MBUS\_READ\_CTL FB allows you to start/stop the M-BUS acquisition;

the MBUS\_WRITE\_RAW FB allows you to build and send a generic M-Bus frame, thus providing a flexible way to send configuration commands to M-Bus devices.

### 8.41.1. M-BUS SCAN

The "SECONDARY SCAN" button allows you to scan the bus, detecting the M-Bus secondary addresses; select the correct baud-rate for the COM1 serial port or select "ALL" to repeat the scan for each possible baud-rate; then click the button; a confirmation pop-up will appear.

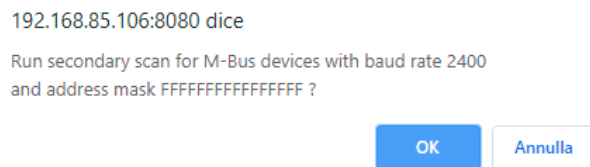

The scanning procedure may take several minutes to complete, so the page shows the number of seconds that have elapsed; devices are displayed in terms of secondary address and baud rate as soon as they are detected.

*M-Bus scan in progress with baud rate 2400, please wait...*  
*(55 seconds elapsed)*

STOP SCAN

#	Baud Rate (2400)	Address (Mask=FFFFFFFFFFFFFFF)
1	2400	00008431614C0402
2	2400	00008432614C0402
3	2400	00008434614C0402
4	2400	00008435614C0402
5	2400	00008436614C0402
6	2400	00008441614C0402
7	2400	00008444614C0402
8	2400	00008446614C0402
9	2400	00008449614C0402
10	2400	00008453614C0402
11	2400	00008454614C0402

The "STOP SCAN" button allows you to cancel the procedure; however the partial results are kept. At the end of the procedure, the webserver indicates the end of the scan and then the following page is displayed:

**M-Bus Scan Parameters**

NOTE: only on serial port COM1 with mode set to Z-MBUS

Baud Rate (bit/s) All

NOTE: "All" means all baud rates except for 38400

Address Mask (for secondary scan) FFFFFFFFFFFFFF

PRIMARY SCAN
SECONDARY SCAN
CREATE CONFIGURATION

READ DATA

#	Baud Rate (2400)	Address (Mask=FFFFFFFFFFFFFF)
1	2400	00008431614C0402
2	2400	00008432614C0402
3	2400	00008434614C0402
4	2400	00008435614C0402
5	2400	00008436614C0402
6	2400	00008441614C0402
7	2400	00008444614C0402
8	2400	00008446614C0402
9	2400	00008449614C0402
10	2400	00008453614C0402
11	2400	00008454614C0402
12	2400	00008458614C0402
13	2400	00008461614C0402
14	2400	00008464614C0402
15	2400	00008466614C0402
16	2400	00008470614C0402
17	2400	00008471614C0402
18	2400	20884031C514010D
19	2400	20884034C514010D

The baud rate value shown in the table header reminds you of the parameter choice for the last scan procedure. The table with the detected M-Bus devices is stored permanently, so after switching the device off and on again the results of the last scan are still available; they will be overwritten by the next scan or deleted by a factory reset.

Similarly, the "PRIMARY SCAN" button allows you to scan the bus, detecting the primary M-Bus addresses; select the correct baud-rate for the COM1 serial port or select "All" to repeat the scan for every possible baud-rate.

It is possible to read the data from one of the devices, selecting the corresponding row and clicking on the "READ DATA" button, for example:

BACK
REFRESH

Id	Manufacturer	Version	Product Name	Medium	Access Num	Status	Signature
8432	SCA	4		Electricity	49	00	0000

#	Value	Unit	Device	Tariff	Storage	Function
0	1	Manufacturer specific	0	0	0	0
1	1	Manufacturer specific	0	0	0	0
2	1	A	0	0	0	0
3	1	Manufacturer specific	0	0	0	0
4	0	Manufacturer specific	0	0	0	0
5	1	Manufacturer specific	0	0	0	0
6	894292975616	Manufacturer specific	0	0	0	0
7	0	Energy (1e-1 Wh)	0	1	0	0
8	0	Energy (1e-1 Wh)	0	1	0	0
9	0	Energy (1e-1 Wh)	0	2	0	0
10	0	Energy (1e-1 Wh)	0	2	0	0
11	0	Manufacturer specific	0	1	0	0
12	0	Manufacturer specific	0	1	0	0
13	0	Manufacturer specific	0	2	0	0
14	0	Manufacturer specific	0	2	0	0
15	0	Manufacturer specific	0	1	0	0
16	0	Manufacturer specific	0	1	0	0
17	0	Manufacturer specific	0	2	0	0
18	0	Manufacturer specific	0	2	0	0

In this page:

- the first table contains only one line, which provides the "slave information";
- the second table contains a variable number of rows, each of which supplies a "data record".

By clicking on the "REFRESH" button it is possible to update the data; by clicking on the "BACK" button you return to the page with the device table.

### 8.41.2. "CREATE CONFIGURATION" BUTTON

Now you can go back to the previous pages and press the "CREATE CONFIGURATION" button.

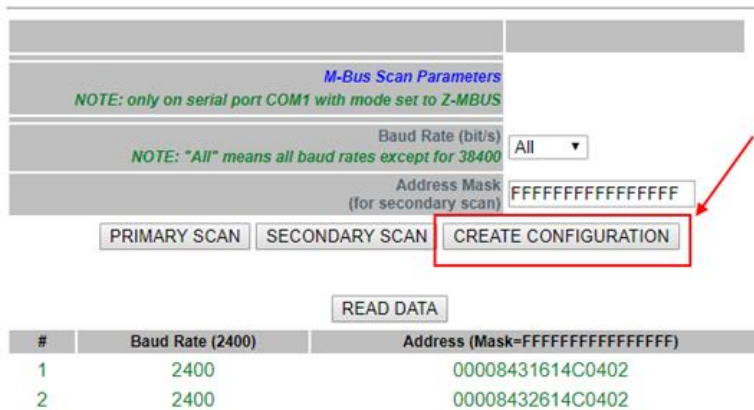

#	Baud Rate (2400)	Address (Mask=FFFFFFFFFFFFFF)
1	2400	00008431614C0402
2	2400	00008432614C0402

This saves the current M-BUS configuration. The web server automatically moves to the next page of "M-Bus Configuration".

### 8.41.3. M-Bus Configuration

After pressing the "Create configuration" button in the M-Bus Scan page you get the following page in the M-Bus configuration:

ADD      DELETE      CREATE TAGS

*NOTE: for each device, tags will have the prefix "MBUSx\_", where "x" is the value in the "Tag Prefix" column.*

Tag Prefix	Baud Rate	Address	Scan Rate (s)
MBUS1	2400	00008431614C0402	60
MBUS2	2400	00008432614C0402	60
MBUS3	2400	00008434614C0402	60
MBUS4	2400	00008435614C0402	60
MBUS5	2400	00008436614C0402	60
MBUS6	2400	00008441614C0402	60
MBUS7	2400	00008444614C0402	60
MBUS8	2400	00008446614C0402	60
MBUS9	2400	00008449614C0402	60
MBUS10	2400	00008453614C0402	60
MBUS11	2400	00008454614C0402	60
MBUS12	2400	00008458614C0402	60
MBUS13	2400	00008461614C0402	60
MBUS14	2400	00008464614C0402	60
MBUS15	2400	00008466614C0402	60
MBUS16	2400	00008470614C0402	60
MBUS17	2400	00008471614C0402	60
MBUS18	2400	20884031C514010D	60
MBUS19	2400	20884034C514010D	60
MBUS20	2400	20884073C514010D	60

The scan result can now be edited.

The first column represents the Tag Prefix name in Straton

The second column represents the Baud Rate to use.

The third column represents the device address.

The fourth column represents the scan time in seconds for this device.

### 8.41.4. IMPORTING THE CONFIGURATION INTO STRATON

First of all we need to export the current configuration.

Energy Protocols: none  
 PLC Status: running (app: mbus\_vars)  
 Router: disabled

---

ADD      DELETE      CREATE TAGS

*NOTE: for each device, tags will have the prefix "MBUSx\_", where "x" is the value in the "Tag Prefix" column.*

Tag Prefix	Baud Rate	Address	Scan Rate (s)
MBUS1	2400	00008431614C0402	60

Now the automatic acquisition of tags starts:



PLC status: running (app: mbus\_vars)

Router: disabled

*M-Bus tags creation in progress, please wait...*

*getting tags from device 3 with address 00008434614C0402 at baud rate 2400 (3/21)*

*(10 seconds elapsed)*

STOP TAGS CREATION

At the end of the process a .zip file (mbus\_tags.zip) will be downloaded by the browser:



The .zip file contains 4 files:

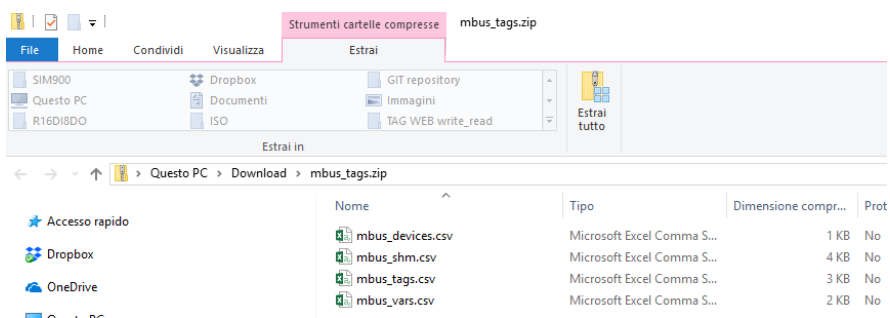

Two of these files are to be used in Straton:  
 mbus\_shm.csv (the shared memory configuration)  
 mbus\_vars.csv (the M-Bus vars)

At this point, perform the following steps:

- 1) Extract the zip file to a directory.
- 2) Start Straton workbench
- 3) Select main and then Global variables:

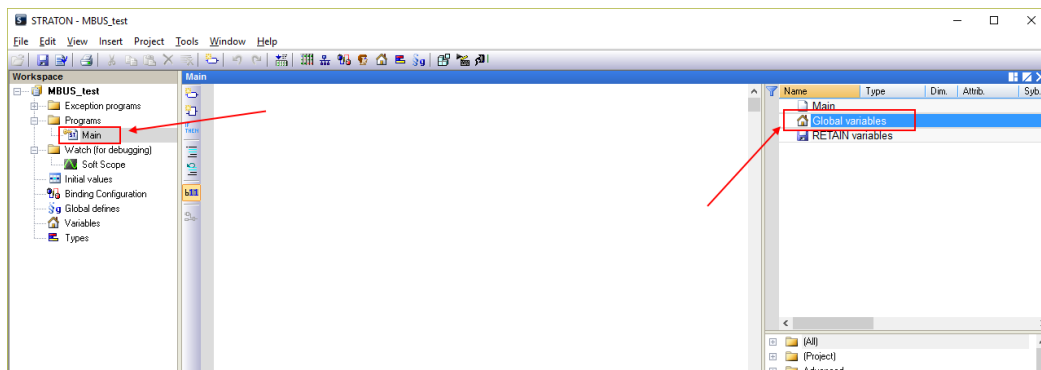

Click the right mouse button and select “Edit Variables as Text”:

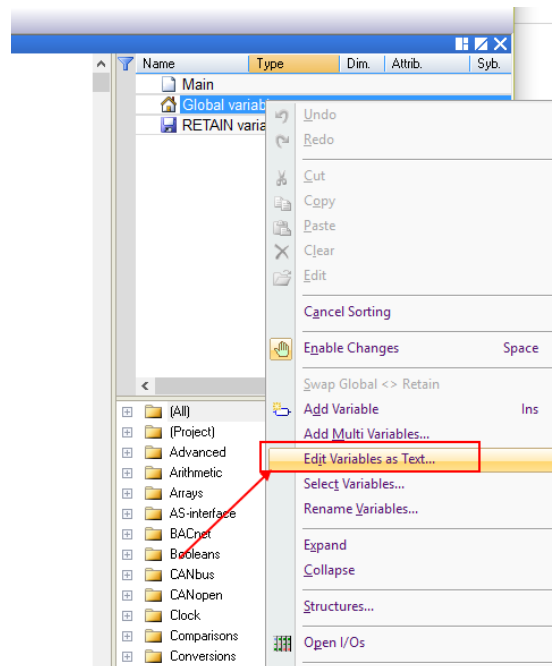

Open the “mbus\_vars.csv” file with a text editor, copy and paste the list of variables into the "Global variables" module in Straton then save the configuration with the "disk" icon:

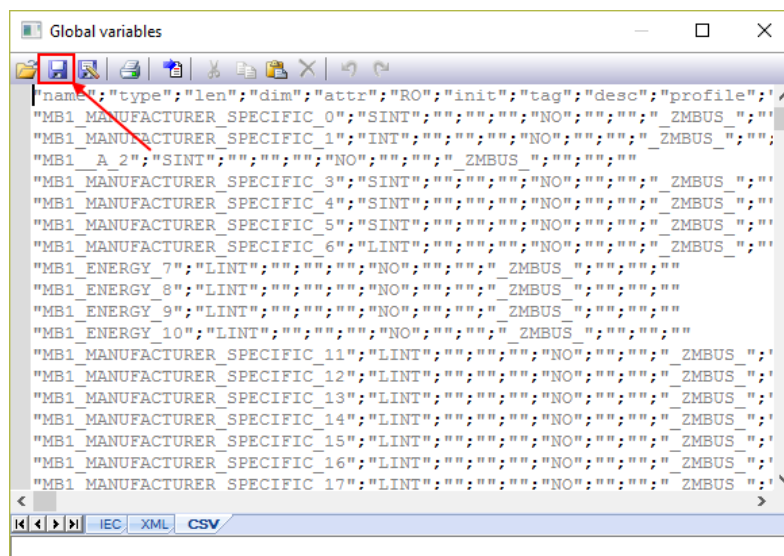

**NOTE: The first line**  
**“name”,”type”,”len”;**...  
**must occur only once and only on the first line.**

Now the variables are imported:

Name	Type	Dim.	Attrib.	Syb.	Init
Main					
Global variables					
MB1_MANUFACTURER_SPECIFIC_0	SINT				<input type="checkbox"/>
MB1_MANUFACTURER_SPECIFIC_1	INT				<input type="checkbox"/>
MB1_A_2	SINT				<input type="checkbox"/>
MB1_MANUFACTURER_SPECIFIC_3	SINT				<input type="checkbox"/>
MB1_MANUFACTURER_SPECIFIC_4	SINT				<input type="checkbox"/>
MB1_MANUFACTURER_SPECIFIC_5	SINT				<input type="checkbox"/>
MB1_MANUFACTURER_SPECIFIC_6	LINT				<input type="checkbox"/>
MB1_ENERGY_7	LINT				<input type="checkbox"/>
MB1_ENERGY_8	LINT				<input type="checkbox"/>
MB1_ENERGY_9	LINT				<input type="checkbox"/>
MB1_ENERGY_10	LINT				<input type="checkbox"/>
MB1_MANUFACTURER_SPECIFIC_11	LINT				<input type="checkbox"/>
MB1_MANUFACTURER_SPECIFIC_12	LINT				<input type="checkbox"/>
MB1_MANUFACTURER_SPECIFIC_13	LINT				<input type="checkbox"/>
MB1_MANUFACTURER_SPECIFIC_14	LINT				<input type="checkbox"/>
MB1_MANUFACTURER_SPECIFIC_15	LINT				<input type="checkbox"/>
MB1_MANUFACTURER_SPECIFIC_16	LINT				<input type="checkbox"/>
MB1_MANUFACTURER_SPECIFIC_17	LINT				<input type="checkbox"/>

Now we need to create the shared memory used to share data from M-BUS:

Click on the fieldbus icon:

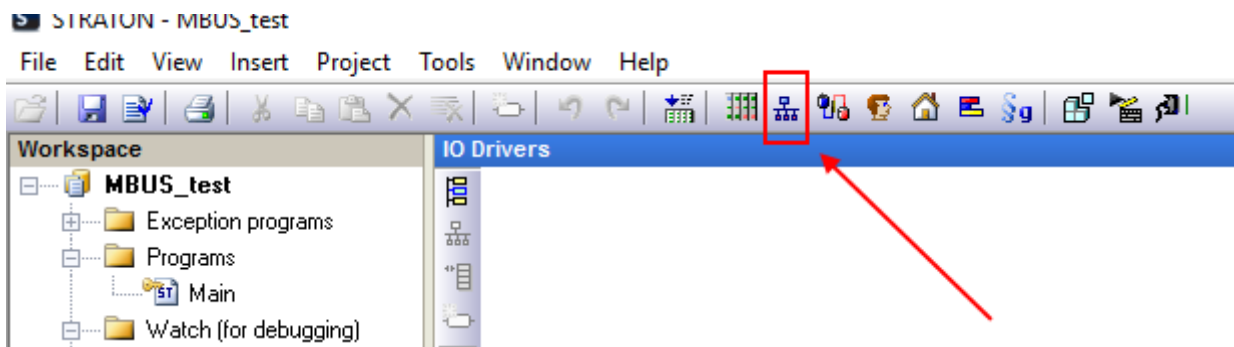

Right-click and select "Insert Configuration":

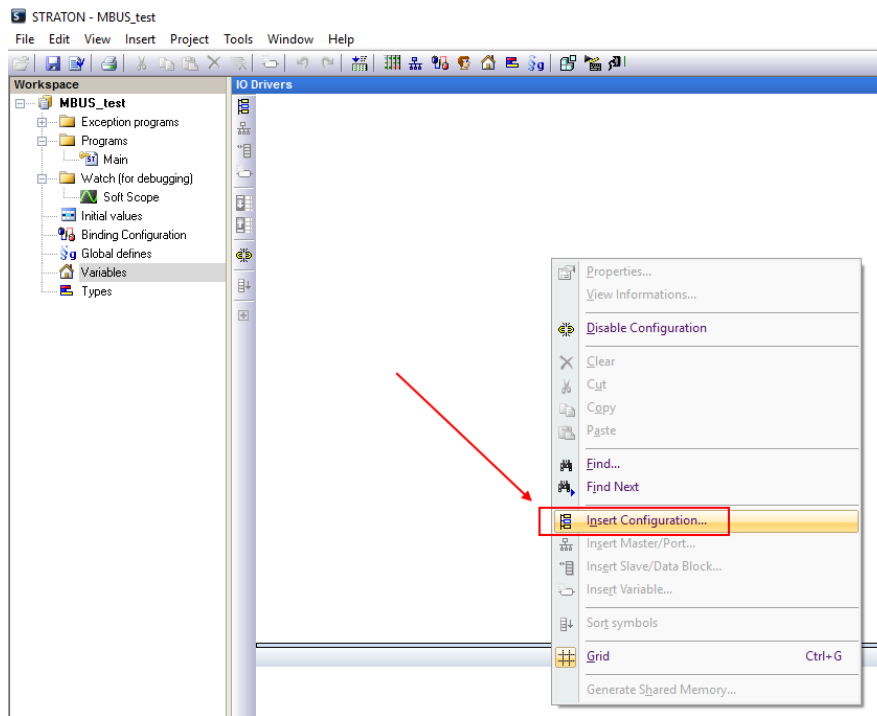

Now create the Shared Memory:

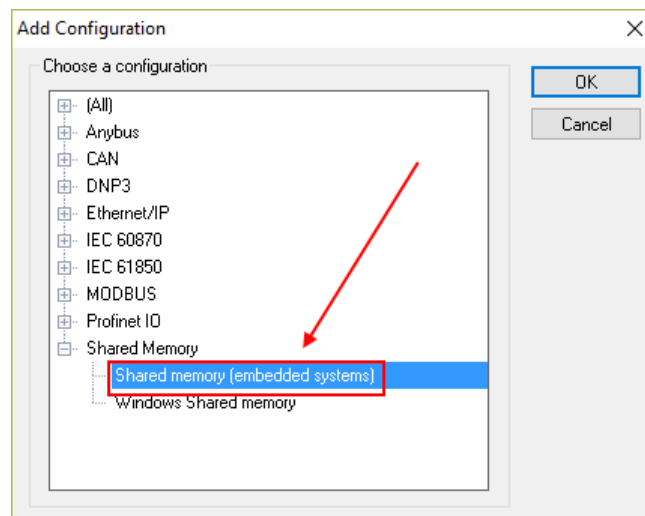

Enter a Master port:

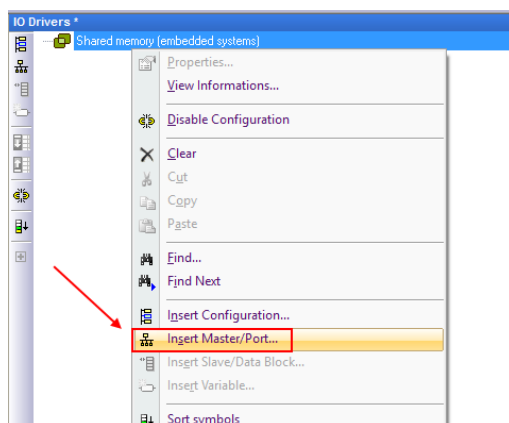

The shared memory configuration must be as shown in the figure (do not change the setting):

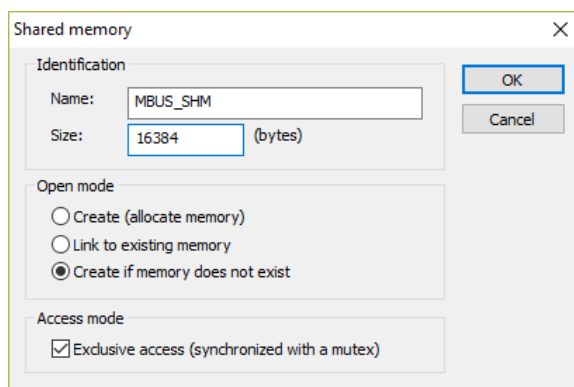

Now insert the data block:

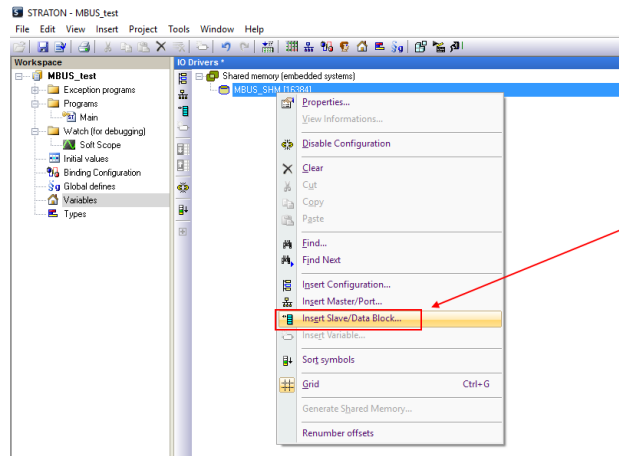

Create a Group and enter a name:

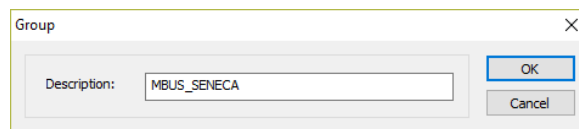

Now import the shared memory file:

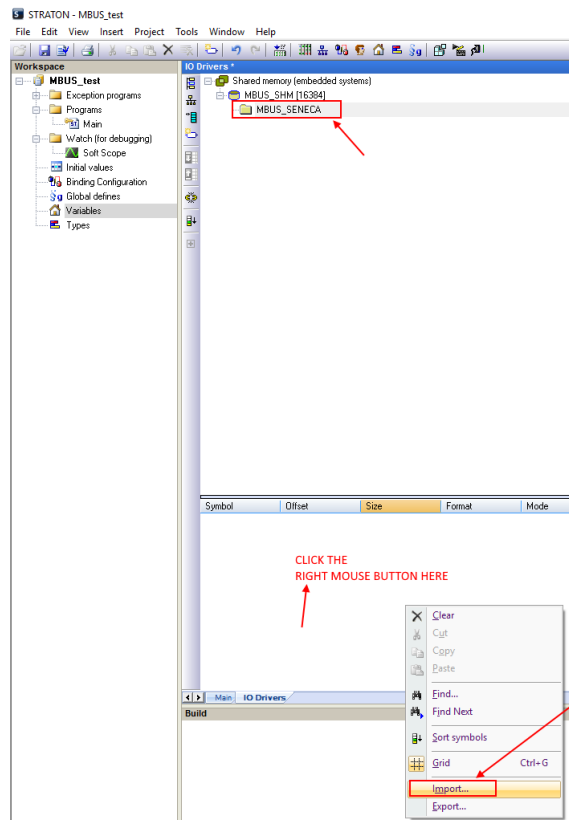

Select the “mbus\_shm.csv” file:

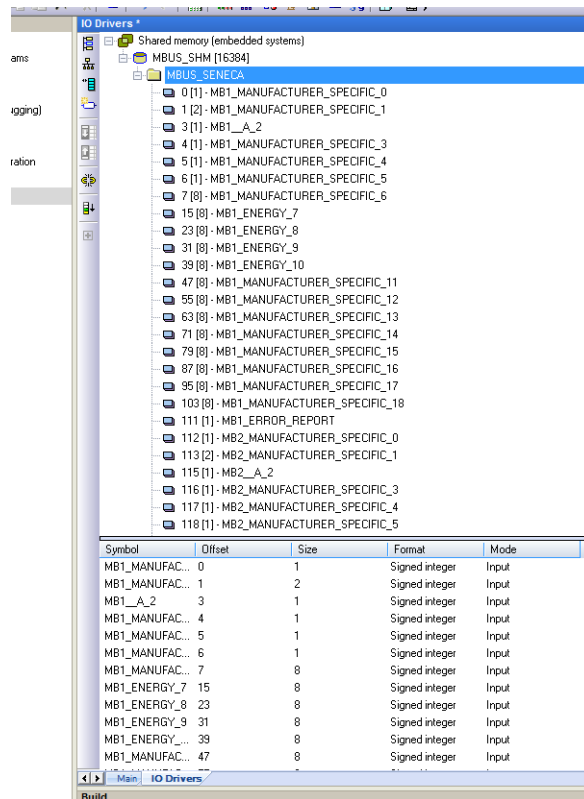

### 8.41.5. DELETING UNUSED MBUS VARIABLES

To delete one or more variables delete the variables and the corresponding shared memory entry:

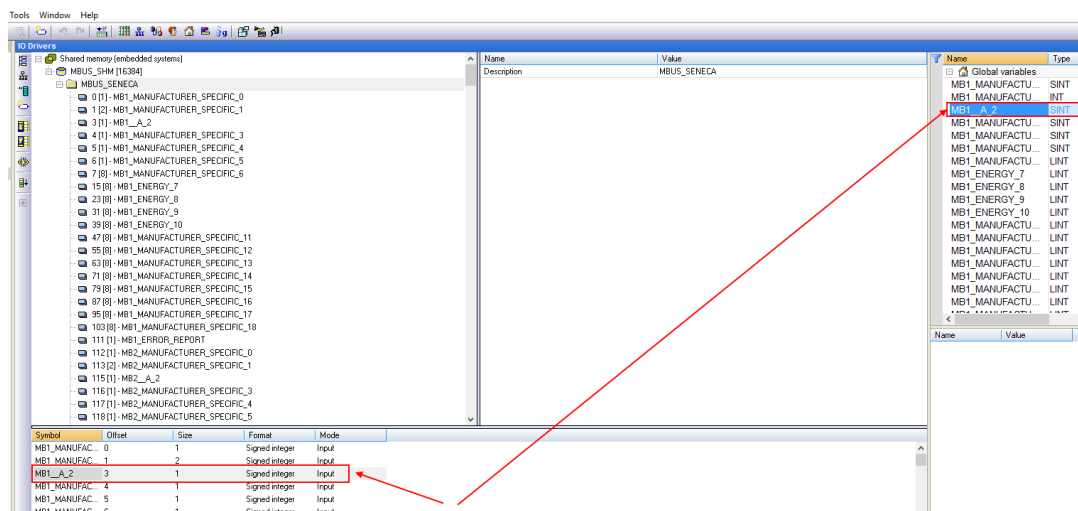



Note that in the shared memory the offsets of other variables are not changed:

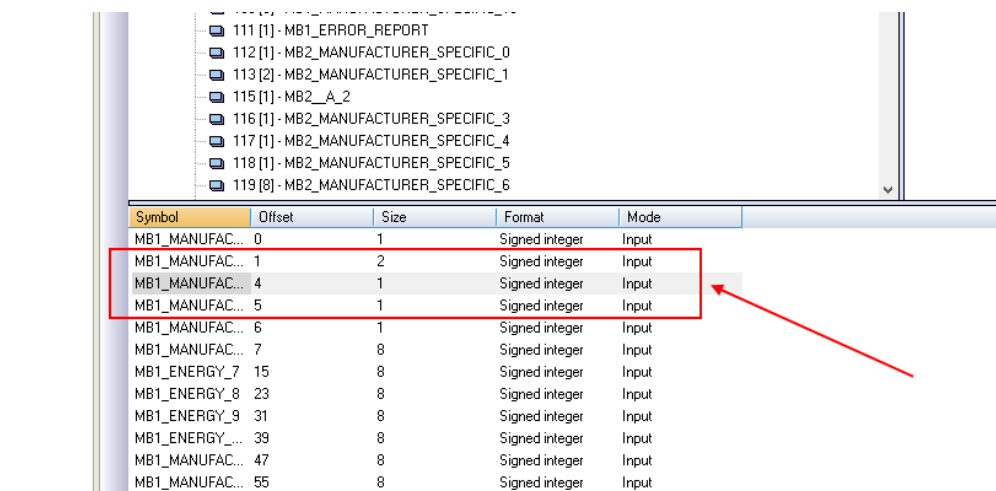

Symbol	Offset	Size	Format	Mode
MB1_MANUFAC...	0	1	Signed integer	Input
MB1_MANUFAC...	1	2	Signed integer	Input
MB1_MANUFAC...	4	1	Signed integer	Input
MB1_MANUFAC...	5	1	Signed integer	Input
MB1_MANUFAC...	6	1	Signed integer	Input
MB1_MANUFAC...	7	8	Signed integer	Input
MB1_ENERGY_7	15	8	Signed integer	Input
MB1_ENERGY_8	23	8	Signed integer	Input
MB1_ENERGY_9	31	8	Signed integer	Input
MB1_ENERGY_...	39	8	Signed integer	Input
MB1_MANUFAC...	47	8	Signed integer	Input
MB1_MANUFAC...	55	8	Signed integer	Input

#### 8.41.6. REPLACING AN M-BUS DEVICE

To replace an existing M-BUS device (e.g. in case of replacement due to failure)

1. Go to M-BUS Scan and do a Secondary or Primary Scan
2. Make a note of the new address
3. Go to M-BUS Configuration and manually change the address from the old to the new device
4. Press the "Create Tag" button.
5. There is no need to make any modifications to the Straton

#### 8.41.7. ADDING AN M-BUS DEVICE

1. Go to "M-BUS Scan" and run a secondary or primary scan
2. Note the new address and baud rate
3. Go to "M-BUS Configuration" and manually add the address and baud rate of the new device with the "ADD" button
4. Press the "Create Tag" button.
5. Import the shared memory file
6. Import the variable file without deleting your local variable (use copy-paste)

#### 8.41.8. DELETING AN MBUS DEVICE

1. Go to M-BUS Scan and do a Secondary or Primary Scan
2. Note the address of the device to be deleted
3. Go to "M-BUS Configuration" and manually delete the device with the "Delete" button.

4. Press the "Create Tag" button.
5. Import the shared memory file
6. Delete the variables from the deleted device

#### 8.41.9. "TAG ERROR REPORT" SPECIAL TAG

When variable tags are imported into Straton, a special "Tag error report" tag is created. Use this tag to monitor device communication errors:

<b>VALUE OF THE "ERORR REPORT" TAG</b>	<b>MEANING</b>
0	READING OK
-2	READING IN TIMEOUT, NO ANSWER FROM THE DEVICE

#### 8.42. CUSTOM IMAGES PAGE (GUI CONFIGURATION)

The devices already have a library of hundreds of symbols integrated to be used in their dashboards or synoptics of the physical graphic (in models with a display) or virtual interface.

This page allows you to upload images created by the user (for example to customize the synoptics with company logos etc.).

It is possible to upload .png and .jpg images with a colour depth of 8 bits. It is recommended to upload images with a maximum resolution of 800x 480 pixels.

Once the images are uploaded on this page they will be added to the symbol library.

If you save and export the configuration, the custom images will also be saved.

#### 8.43. ETHERNET INTERFACES PAGE (MAINTENANCE)

The addresses and statistics of the device's Ethernet ports are shown here.

#### 8.44. MODBUS SERIAL TRACE PAGE (MAINTENANCE)

This is a serial sniffer useful for analyzing serial traffic. You can also export traffic in csv format for later analysis.

<i>NOTE: to let the trace properly run, only one instance of this page shall be run in a given moment; before exiting the page, it's better to stop the trace.</i>	<input type="button" value="START/STOP"/>	<span style="background-color: #90EE90; padding: 2px 5px;"><b>RUNNING</b></span>	<input type="button" value="EXPORT TO CSV"/>	<i>NOTE: this page does not apply to serial ports handled by the PLC.</i>
--	---	--	--	---

INDEX	TIME DIFF (ms)	PORT	TYPE	LEN	PACKET
-------	----------------	------	------	-----	--------

#### 8.45. FW VERSION PAGE (MAINTENANCE)

This page lists the revisions of the firmware version in use and the previous installed version. The device always includes the previous installation.

#### 8.46. FIRMWARE UPGRADE PAGE (MAINTENANCE)

Allows you to update the firmware of the device.

#### 8.47. MANAGEMENT CONF. PAGE (MAINTENANCE)

Allows you to export or import the configuration of the device (useful if you need to copy the configuration to another device).

Always on the same page you can save the system log files (debug log) to be sent to Seneca support and upload the RSA algorithm key for accessing the ssh service.

#### 8.48. LICENCE MANAGEMENT (MAINTENANCE)

Here you can check which optional features are enabled under "Optional Features".

It is also possible to enter the activation keys provided by Seneca to add optional features to the device.

For example, it is possible to add Straton PLC function to a device that does not already have it.

For more information please refer to Seneca support.

#### 8.49. MODBUS MODULES (MAINTENANCE)

If you use the PLC in legacy mode and use the legacy Z-NET4 configuration software, the list of connected Modbus devices appears on this page.

**8.50. PLC MODE CONFIGURATION (MAINTENANCE)**

On this page you can choose the operating mode of the Straton PLC.

<b>Field</b>	<b>Meaning</b>
PLC Mode	<p>“None” the PLC is disabled</p> <p>“Legacy” the PLC is in compatibility mode for use with configurations prior to firmware 3.x.x.x. revision To use the Z-NET4 configuration software it is essential to set the PLC in this mode. This is the default mode for “-S” or “-E” devices. In this mode the virtual display, data logger, alarms etc. are not available</p> <p>“Shared” the PLC is in shared mode, i.e. it can share the TAGs between the PLC and the firmware and therefore take advantage of all the new features of firmware 3.x.x.x. versions Configuration with Z-NET4 is no longer possible</p>

## 9. VPN

A VPN (Virtual Private Network) is a virtual private network that provides privacy, anonymity and security through a communication channel (VPN tunnel) created over a public network infrastructure.

Devices can create VPNs using Seneca LET'S technology which is based on a VPN BOX 2 server.

It is also possible to connect to standard OpenVPN servers.



For more information on Let's technology visit:

<https://www.seneca.it/linee-di-prodotto/comunicazione-industriale-e-telecontrollo/lets-connectivity-solutions/>

For further information on OpenVpn, see the website:

<https://openvpn.net/>

For more information on VPN BOX 2, refer to:

<https://www.seneca.it/linee-di-prodotto/comunicazione-industriale-e-telecontrollo/lets-connectivity-solutions/modulo-server-di-connettivita/>

The device supports VPN connection using two different servers: Seneca VPN BOX2 and a standard OpenVPN Server.

The main advantages of using a VPN are:

- secure connections so the transmitted data are encrypted;
- the ability to establish connections without interfering with the corporate LAN;
- no need to have a static/public IP address
- on the WAN side; remote configurability via Web Server

Two "VPN modes" are available, respectively named "OpenVPN" and "VPN BOX".

The "OpenVPN" mode can be used when the device is to be installed in an existing VPN. In this case, an OpenVPN server must be available and configuration, certificates and key files for the Seneca Client must be provided by the VPN administrator.

Files can be uploaded to the device using the dedicated web page.

If the VPN infrastructure is not available, the recommended choice is to adopt the "VPN Box2" solution developed by Seneca.

"VPN Box2" is a hardware device (also available in virtual machine version) that allows the user to easily configure two alternative types of VPN:

- "VPN "Single LAN" (Always on for SCADA systems)
- VPN "Point-to-Point" (On demand for remote maintenance of the machine)

In "Single LAN" VPN, all devices and PCs (and associated local sub-networks) configured in VPN are always connected in the same network. In this scenario any VPN Client (PC or Seneca device) can communicate each other but also with the machines/devices connected to any Seneca device LAN, for this reason, all VPN Clients must have different network configuration.

In the "Point-to-Point" VPN, a client PC, at a given moment, can perform a single connection, upon request, to only one device at a time (and to the machines that are connected to the LAN port of the Seneca device).

Furthermore, the devices cannot communicate with each other even if they belong to the same VPN.

The advantage of this architecture is that the same subnetwork can be used at all sites. The point-to-point mode is the most used in case of remote maintenance of the systems.

There are two types of Point to Point VPN connection.

- Layer 3 VPN
- Layer 2 VPN

In "Layer 3 VPN", only IP packets (Layer 3) are transported through the VPN tunnel.

On the other side, in "Bridging Layer 2 VPN", all Ethernet frames are transported through the VPN tunnel

Each mode has advantages and disadvantages:

#### Layer 2

- can carry any network protocol (e.g. Siemens™ Profinet protocol scanning)
- causes more traffic on the VPN tunnel than layer3

#### Layer 3

- can carry only IP traffic
- layer2 traffic (e.g.: DHCP) is not transported
- reduces traffic management costs, transports only traffic destined for clients

The "VPN Box2" comes with two Windows applications: "VPN Client Communicator" allows the user to connect the PC to the network (in the "Single LAN" case) or to a specific device (in the "Point-to-Point" case)

9.1. VPN "SINGLE LAN" ALWAYS ON

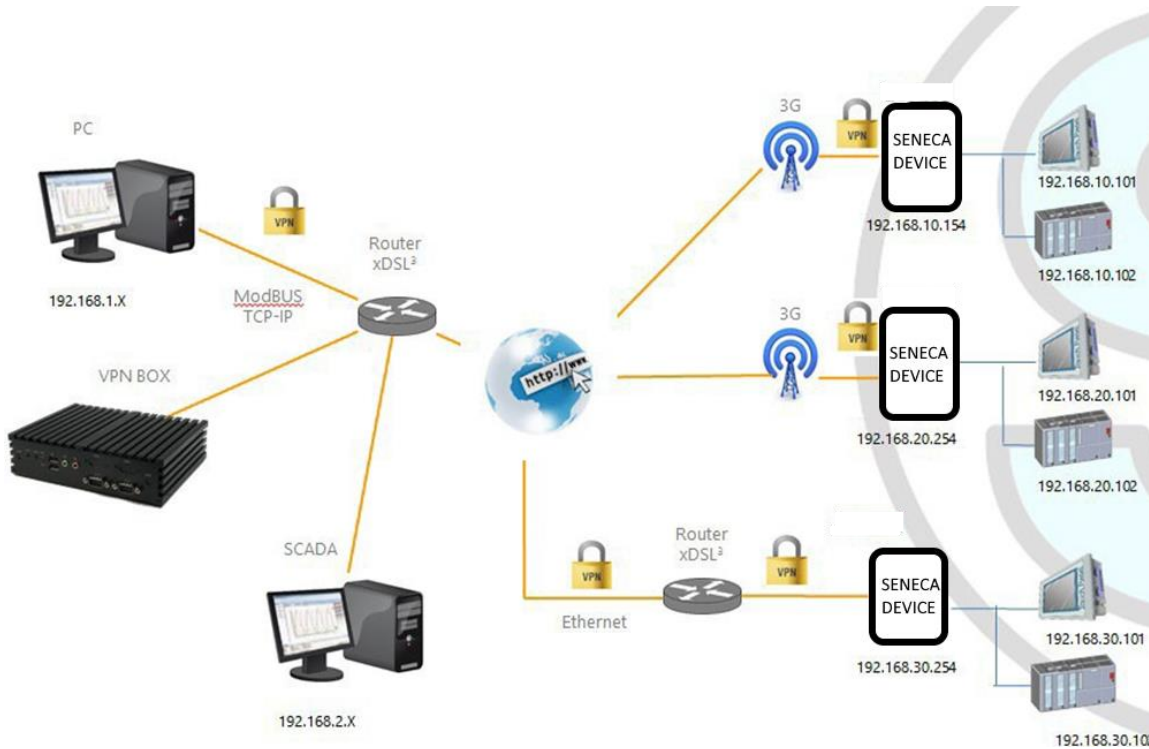

The figure above provides an example of VPN

The client PC (with IP address 192.168.1.X) can connect, as an example, to the first Seneca device using its local IP address.

Also, two devices that are in two different LANs of the same VPN network (e.g.: 192.168.10.101 and 192.168.20.102) can connect to each other, again using their local IP addresses.

In order for this scenario to work properly, one essential rule must always be followed: the LANs of the Seneca device and the LAN of the PC must have different subnets and not in collision; therefore, in the figure above, the following is shown

PC LAN	192.168.1.0/24
SCADA LAN	192.168.2.0/24
SENECA DEVICE LAN	192.168.10.0/24
	4
SENECA DEVICE LAN	192.168.20.0/24
	4
SENECA DEVICE LAN	192.168.30.0/24
	4

If conflicts cannot be avoided, it is still possible to use a "Single LAN" VPN because devices can be reached via their VPN IP addresses and machines beyond them can be reached by configuring "port forwarding" rules.

### 9.2. VPN "POINT TO POINT" ON DEMAND

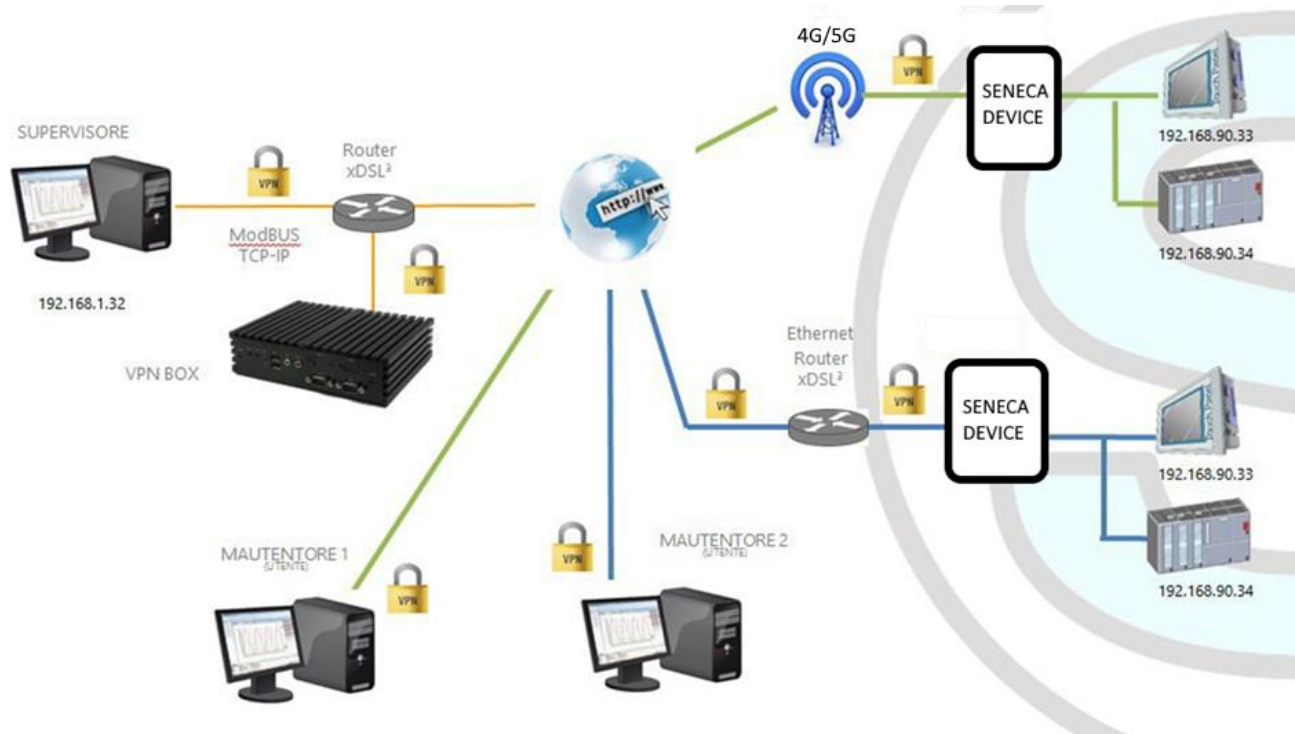

The figure above provides an example of "Point-to-Point" VPN.

In this scenario a PC (acting as a VPN client) can connect, on demand, to a Seneca device and its subnet using local IP addresses via the VPN Client Communicator application . The software guarantees group management of users to allow only those who belong to a group to access the systems that are part of it

### 9.3. DISABLING THE VPN CONNECTION

The products provide an integrated digital input and digital output dedicated to control and monitor the remote connection to the device.

In this way it is possible to block access (via digital input) remotely to a particular machine/plant (e.g. if local maintenance operations are being carried out) and be informed of a remote access in progress (via digital output).

When the "Remote Connection Disable" digital input is set to HIGH, the remote connection to the device is disabled; conversely, when the "Remote Connection Disable" digital input is set to LOW, the remote connection to the device is enabled.

The "Remote Connection Active" digital output is set to the HIGH state when the device is connected.

Four security levels can be configured to disable the remote VPN connection:



Level 1: VPN connections are disabled in any VPN mode but the "VPN Box Service" service is still running, so the device can still be monitored on VPN Box Manager;

Level 2: The "VPN Box Service" is disabled, but the device can still access the Internet and send/receive SMS on a possible cellular interface;

Level 3: any Internet access is disabled, but the device can still send/receive SMS on a possible cellular interface;

Level 4: As level 3 but also the cellular interface is switched off

#### **9.4. CONFIGURATION FILE FOR USE WITH OPEN VPN**

This paragraph provides an example of OpenVPN server configuration.

```
port 1194
proto udp
dev tun
ca ca.crt
cert server.crt
key server.key
dh dh1024.pem
server 10.9.7.0 255.255.255.0
ifconfig-pool-persist ipp.txt
client-config-dir ccd
client-to-client
keepalive 10 120
comp-lzo
persist-key
persist-tun
status openvpn-status.log
verb 3
```

This paragraph provides an example of the device client Open VPN configuration.

```
client
dev tun
port 1194
proto udp
remote 2.192.5.105 1194
nobind
ca ca.crt
cert tws4.crt
key tws4.key
comp-lzo
persist-key
persist-tun
script-security 3 system
verb 3
```

## 10. COMMUNICATION NETWORK REDUNDANCY

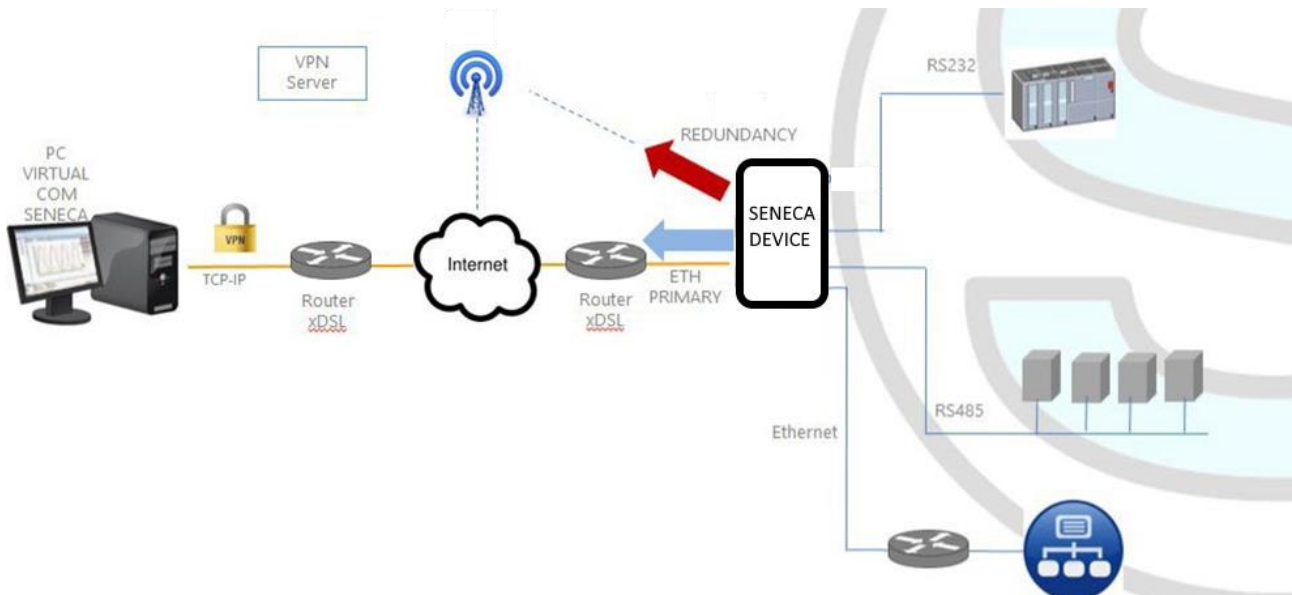

“Network redundancy” is a feature that can be enabled on devices where a mobile or WI-FI modem is available.

This feature is intended to switch the used network interface to access the Internet from Ethernet (“primary” interface) to the secondary interface (Cellular or WI-FI modem), when Internet access through the primary interface becomes unavailable the system draws on the internet via the configured secondary channel. When the Internet service becomes available again from the primary interface the access returns to the latter.

## 11. MQTT CLIENT PROTOCOL

MQTT is the most widely used protocol for IOT applications.

*“MQTT” stands for MQ Telemetry Transport. It is an extremely simple and lightweight public/subscription messaging protocol designed for devices with low bandwidth, high latency or unreliable networks. The design principles are to minimize network bandwidth and device resource requirements while trying to ensure reliability and a certain degree of delivery guarantee. These principles prove ideal for the emerging machine-to-machine (M2M) or Internet of Things world.*

For more information on the MQTT protocol see



The MQTT version supported is 3.1.1

### 11.1. MQTT PROTOCOL IMPLEMENTATION FEATURES

The MQTT protocol can be enabled together with the other client protocols (USB, FTP, EMAIL, ...); however, when the MQTT protocol is enabled, the following changes apply to the behaviour of the Data Logger

The MQTT protocol also allows you to perform the following actions on the device:

- setting the values of one or more tags
- restarting the device
- save the device configuration on the FTP site of the server
- upload the device configuration from the FTP site of the server
- starting the FW update;

There is also an internal cache for LOG messages sent via MQTT requests, used to store log messages while it is not possible to send them to the broker; this cache can hold up to 3000 messages

### 11.2. FEATURES OF THE MQTT PROTOCOL IMPLEMENTATION OF THE STRATON PLC

The MQTT version supported is 3.1.1

To use the MQTT client select it from the Straton Workbench Fieldbus section:

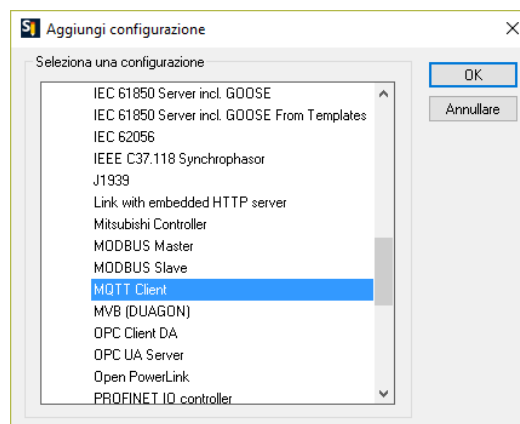

#### 11.2.1. PARAMETERS OF THE MQTT PROTOCOL FROM THE PLC PROGRAM

MQTT setup can be done directly from the workbench:

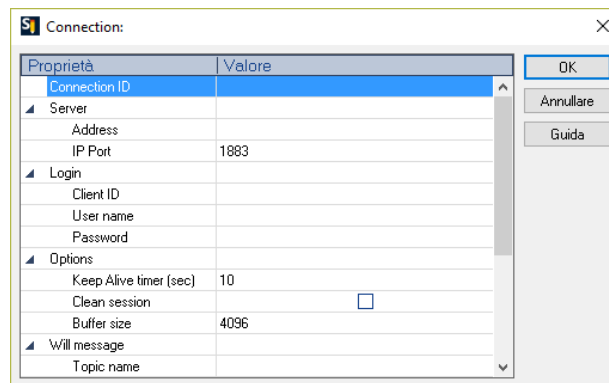

If it is necessary to configure these parameters from the Straton PLC program, a series of special words can be used which will load the configuration from a file.

The special words are:

In the "Address" field type: `mqtt_par_address` so that the "Address" field is obtained from the file:

```
/var/run/mqtt_par_address
```

In the "Client ID" field type: `mqtt_par_clientid` so that the "Client ID" field is obtained from the file:

```
/var/run/mqtt_par_clientid
```

In the "Username" field type: `mqtt_par_username` so that the "Username" field is obtained from the file:

```
/var/run/mqtt_par_username
```

In the "Password" field type: `mqtt_par_password` so that the "Password" field is obtained from the file:

```
/var/esegui/mqtt_par_password
```



## ATTENTION!

**The Address parameter must not contain a FQDN, but the IP address, this is because the MQTTCONNECT FB does not perform DNS resolution.**

**Alternatively, it can contain the name of the file (e.g.: `mqtt_par_address`), created in the `/var/run` directory by the `DNS_RESOLVE` FB and containing the result of the DNS resolution.**

### 11.2.2. MANAGING MULTIPLE MQTT CONNECTIONS

It is possible to manage multiple MQTT connections using parameters starting with the special words (mqtt\_par\_address123, mqtt\_par\_address\_aaa, ...), for example to create 2 mqtt connections:

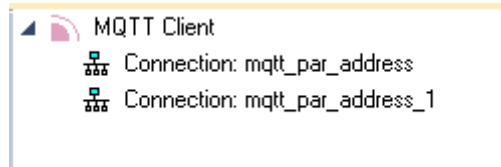

The first connection uses the field address "mqtt\_par\_address"

Nome	Valore
Connection ID	Mosquito_Test_TLS
Server	
Address	mqtt_par_address
IP Port	8883
Login	
Client ID	
User name	

Then it will load the address from the file:

`/var/run/mqtt_par_address`

The second connection uses the stored address "mqtt\_par\_address\_1"

Nome	Valore
Connection ID	DataBoom_no_TLS
Server	
Address	mqtt_par_address_1
IP Port	1883
Login	
Client ID	mqtt_par_clientid_1
User name	mqtt_par_username_1
Password	mqtt_par_password_1
Options	

this will load the address from the file:

`/var/run/mqtt_par_address_1`

(the technique can also be used for the other client id, username and password parameters).

### 11.2.3. MQTT CONFIGURATION OF SSL/TLS RETRYs

The default configuration for MQTT SSL/TLS connection is:

`CONN_TRY_MAX = 10`

`CONN_TRY_WAIT = 1000 ms`

Where:

`CONN_TRY_MAX` is the number of attempts to connect.

`CONN_TRY_WAIT` is the timeout of each connection attempt.

If you need to change this default configuration you need to create the file:

"ssl\_con\_try\_params"

In this path:

`"/var/esegui/"`

With parameter values, for example:

```
root@Z-PASS2-S:~# cat /var/run/ssl_conn_try_params
50.200
```

It means CONN\_TRY\_MAX = 50 and CONN\_TRY\_WAIT = 200 ms.

NOTE1: At the end of the file you need to add an \n (new line character)

NOTE2: The file is loaded into a RAM filesystem, so you need to create it on every boot.

### 11.2.4. STATIC AND DYNAMIC CLIENT CERTIFICATES

In the MQTT configuration under the Security section you can enter the path and file name for the certificates:

Proprietà	Valore
Keep Alive timer (sec)	10
Clean session	<input type="checkbox"/>
Buffer size	4096
Will message	
Topic name	
Contents	
Quality of service	0: At most once
MQTTVersion	3.1.1
<b>Security</b>	
Key file	
Certificate file	
Certificate authority file	
Certificates directory	
Permissible ciphers	

Seneca suggests using the /config directory for certificates.

The MQTT client certificate can only be uploaded from the FTP server.

The key file is the client's private key file.

The certificate file is the client certificate.

The certification authority file is the certification authority certificate.

## ATTENTION!

The “Certificate directory” field is not used so the file name must contain the absolute path example:

“/config/mqtt/client.key”

“/config/mqtt/client.crt”

“/config/mqtt/ca.crt”

If these files and other parameters need to be modified dynamically without recompiling the project, a file can be loaded into the /var/run directory with a file name that must start respectively with:

“mqtt\_par\_clientkey”, “mqtt\_par\_clientcert”, “mqtt\_par\_cacert”

The content of the files must be a text with the file name without the path.

Note that more than one certificate file can be used in a program, for example “mqtt\_par\_clientcert00”, “mqtt\_par\_clientcert01” etc...

### 11.2.5. CHANGING MQTT PARAMETERS IN RUNTIME VIA FILE

You can change the port and the keepalive configuration by overwriting the current configuration with the following files in runtime:

"mqtt\_par\_port" and "mqtt\_par\_keepalive".

The content of the files must be a text with the new parameter value.

## 12. LOGICAL RULES

A logical rule is based on the following concept

"IF -> THEN -> ELSE"

It means:

IF THE CONDITION HAS OCCURRED -> THEN PERFORM THESE ACTIONS -> OTHERWISE PERFORM THESE OTHER ACTIONS

You can define up to 2000 rules.

In each rule can also be configured:

- Combinations of up to three logical conditions (based on alarm states) in AND/OR logical expression;
- up to three actions can be performed

Using logical rules it is therefore possible to execute programs that use internal or external I/O, send text messages and/or write TAGs via MODBUS / EMAIL / SMS / http / MQTT etc. even using complex mathematical operations.

Rules can also be debugged through step-by-step execution and the use of breakpoints that block program execution on a specific line (rule).

A rule consists of one or more "If Condition", one or more "Then Action" and one or more "Else Action".

Schematically a rule performs the following flow:

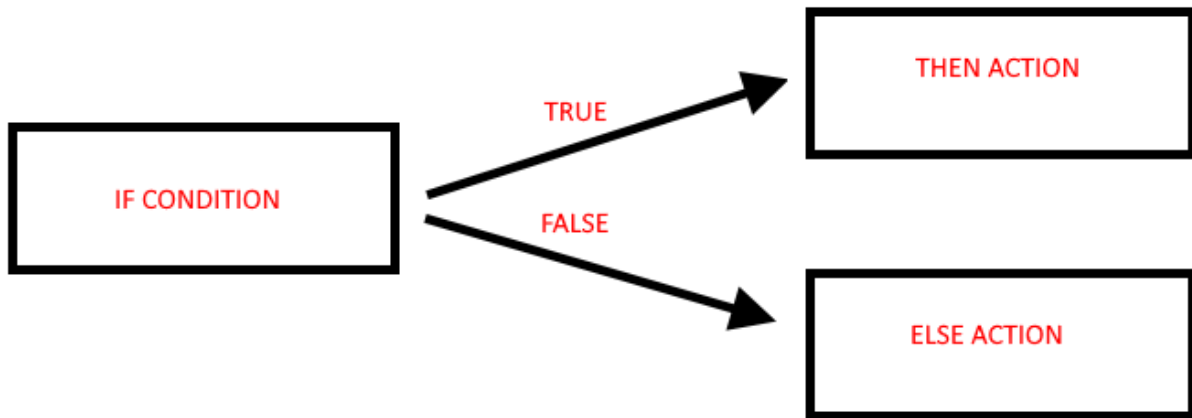

If the "IF" condition is true, the "THEN" action is executed, otherwise the "ELSE" action is executed.

The rules are executed from top to bottom and from left to right (in figure 1-> 2-> 3-> 4):

		CURRENT	UPDATED												
<b>RULE GENERAL CONFIGURATION</b>															
Writing Mode		After execution	After execution												
APPLY															
<b>RULE STATUS</b>															
Run Status		RUNNING													
Cycle Time (ms)		0													
Rule Management															
ADD    MODIFY    COPY    MOVE    DELETE    DELETE ALL															
Rule Debugger															
SET/RESET BREAKPOINT    PLAY    SHOW TAGS															
#	Enabled	Index	Description	Period (ms)	If condition 1	If condition 2	If condition 3	Then action 1	Then action 2	Then action 3	Else action 1	Else action 2	Else action 3	Condition Status	Breakpoint
1	ON	1	Calculate Biggest Circumference	1000	RADIUS1 > RADIUS2	OR	---	CIRCUMFERENCE = RADIUS1 * 6.28	---	---	CIRCUMFERENCE = RADIUS2 * 6.28	---	---	FALSE	2
2	ON	2	Calculate Biggest Area	1000	RADIUS1 > RADIUS2	OR	---	AREA = RADIUS1 * RADIUS1	AREA = RADIUS1 * 3.14	---	AREA = RADIUS2 * RADIUS2	AREA = RADIUS2 * 3.14	---	FALSE	4

When all the rules are executed, the execution starts again from the first one.

More in detail the correct diagram is:

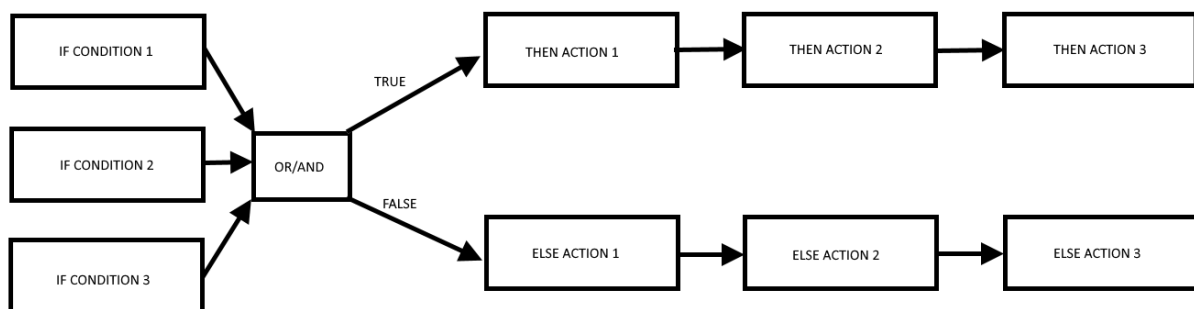

It is in fact possible to define up to 3 if conditions and up to 3 actions for both the THEN and ELSE state.



It is possible to create up to 2000 different rules.

In the "Rule General Configuration" you can choose when Tags are written to shared memory, you can choose between "After Execution" or "During Execution".

With "After Execution", you get tag values written to shared memory only when all the rules HAVE been executed.

With "During Execution", you get tag values written to shared memory at the end of each single rule.

Therefore, using the "After Execution" mode, the new tag values will only be updated at the end of all rules (even tags that must be written on MODBUS RTU / TCP-IP).

The rule status will show the execution status (if the rules are in execution or pause mode) and the loop time which represents the time taken to execute all the rules (note that if you need to write tags with modbus protocol, the loop time will also include the time taken for this operation).

### 12.1. CREATION OF A PROGRAM WITH LOGICAL RULES

We will create an example program that, given 2 different radii of a circle, calculates the maximum circumference and the maximum area.

First of all we add the Tags we need for the program:

We define the Radius1 and Radius2 tags as integer type

Circumference and Area in Real 32 bits (floating point single precision):

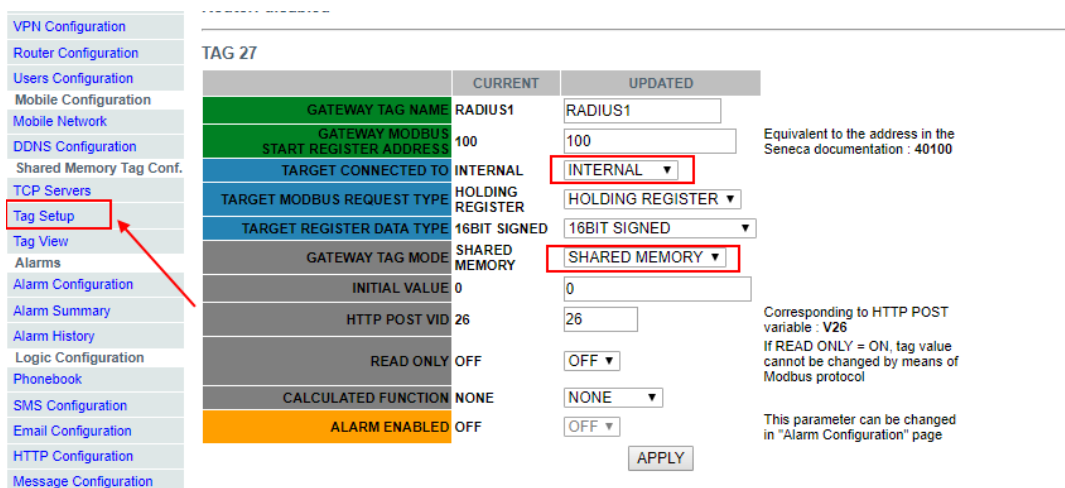

	CURRENT	UPDATED	
GATEWAY TAG NAME	RADIUS1	RADIUS1	
GATEWAY MODBUS START REGISTER ADDRESS	100	100	Equivalent to the address in the Seneca documentation : 40100
TARGET CONNECTED TO	INTERNAL	INTERNAL	
TARGET MODBUS REQUEST TYPE	HOLDING REGISTER	HOLDING REGISTER	
TARGET REGISTER DATA TYPE	16BIT SIGNED	16BIT SIGNED	
GATEWAY TAG MODE	SHARED MEMORY	SHARED MEMORY	
INITIAL VALUE	0	0	
HTTP POST VID	26	26	Corresponding to HTTP POST variable : V26 If READ ONLY = ON, tag value cannot be changed by means of Modbus protocol
READ ONLY	OFF	OFF	
CALCULATED FUNCTION	NONE	NONE	
ALARM ENABLED	OFF	OFF	This parameter can be changed in "Alarm Configuration" page

	CURRENT	UPDATED	
GATEWAY TAG NAME	RADIUS2	<input type="text" value="RADIUS2"/>	
GATEWAY MODBUS START REGISTER ADDRESS	101	<input type="text" value="101"/>	Equivalent to the address in the Seneca documentation : 40101
TARGET CONNECTED TO	INTERNAL	<input type="text" value="INTERNAL"/>	
TARGET MODBUS REQUEST TYPE	HOLDING REGISTER	<input type="text" value="HOLDING REGISTER"/>	
TARGET REGISTER DATA TYPE	16BIT SIGNED	<input type="text" value="16BIT SIGNED"/>	
GATEWAY TAG MODE	SHARED MEMORY	<input type="text" value="SHARED MEMORY"/>	
INITIAL VALUE	0	<input type="text" value="0"/>	
HTTP POST VID	27	<input type="text" value="27"/>	Corresponding to HTTP POST variable : V27
READ ONLY	OFF	<input type="text" value="OFF"/>	If READ ONLY = ON, tag value cannot be changed by means of Modbus protocol
CALCULATED FUNCTION	NONE	<input type="text" value="NONE"/>	
ALARM ENABLED	OFF	<input type="text" value="OFF"/>	This parameter can be changed in "Alarm Configuration" page

### TAG 29

	CURRENT	UPDATED	
GATEWAY TAG NAME	CIRCUMFERENCE	<input type="text" value="CIRCUMFERENCE"/>	
GATEWAY MODBUS START REGISTER ADDRESS	103	<input type="text" value="103"/>	Equivalent to the address in the Seneca documentation : 40103
TARGET CONNECTED TO	INTERNAL	<input type="text" value="INTERNAL"/>	
TARGET MODBUS REQUEST TYPE	HOLDING REGISTER	<input type="text" value="HOLDING REGISTER"/>	
TARGET REGISTER DATA TYPE	32BIT REAL MSW	<input type="text" value="32BIT REAL MSW"/>	
GATEWAY TAG MODE	SHARED MEMORY	<input type="text" value="SHARED MEMORY"/>	
INITIAL VALUE	0	<input type="text" value="0"/>	
HTTP POST VID	28	<input type="text" value="28"/>	Corresponding to HTTP POST variable : V28
READ ONLY	OFF	<input type="text" value="OFF"/>	If READ ONLY = ON, tag value cannot be changed by means of Modbus protocol
CALCULATED FUNCTION	NONE	<input type="text" value="NONE"/>	
ALARM ENABLED	OFF	<input type="text" value="OFF"/>	This parameter can be changed in "Alarm Configuration" page

### TAG 30

	CURRENT	UPDATED	
GATEWAY TAG NAME	AREA	<input type="text" value="AREA"/>	
GATEWAY MODBUS START REGISTER ADDRESS	105	<input type="text" value="105"/>	Equivalent to the address in the Seneca documentation : 40105
TARGET CONNECTED TO	INTERNAL	<input type="text" value="INTERNAL"/>	
TARGET MODBUS REQUEST TYPE	HOLDING REGISTER	<input type="text" value="HOLDING REGISTER"/>	
TARGET REGISTER DATA TYPE	32BIT REAL MSW	<input type="text" value="32BIT REAL MSW"/>	
GATEWAY TAG MODE	SHARED MEMORY	<input type="text" value="SHARED MEMORY"/>	
INITIAL VALUE	0	<input type="text" value="0"/>	
HTTP POST VID	29	<input type="text" value="29"/>	Corresponding to HTTP POST variable : V29
READ ONLY	OFF	<input type="text" value="OFF"/>	If READ ONLY = ON, tag value cannot be changed by means of Modbus protocol
CALCULATED FUNCTION	NONE	<input type="text" value="NONE"/>	
ALARM ENABLED	OFF	<input type="text" value="OFF"/>	This parameter can be changed in "Alarm Configuration" page

Now click on "Rules Management" and then on ADD to add a new rule:

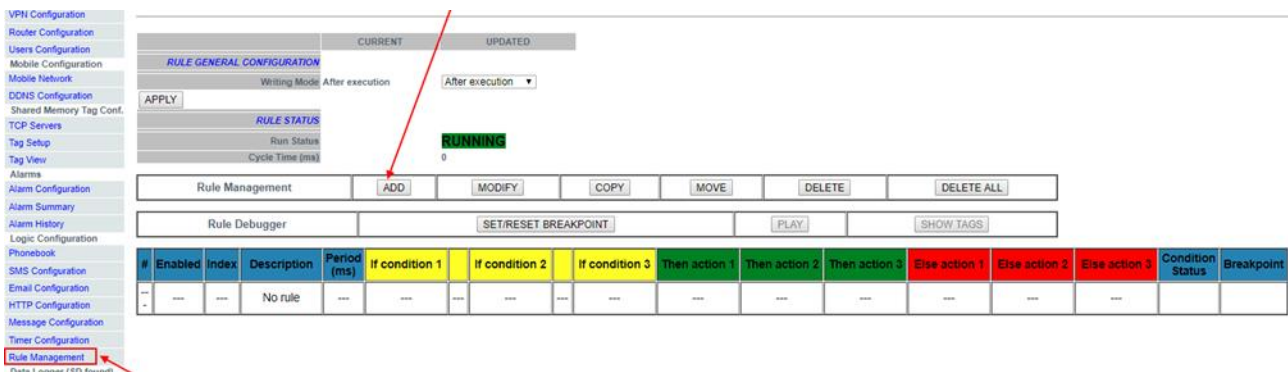

The screenshot shows the 'Rule Management' interface. On the left is a navigation menu with 'Rule Management' highlighted. The main area has tabs for 'CURRENT' and 'UPDATED'. Below these are sections for 'RULE GENERAL CONFIGURATION' (with 'Writing Mode' and 'After execution' dropdowns), 'RULE STATUS' (showing 'RUNNING' and '0'), and a 'Rule Management' toolbar with buttons for 'ADD', 'MODIFY', 'COPY', 'MOVE', 'DELETE', and 'DELETE ALL'. Below the toolbar is a 'Rule Debugger' section with 'SET/RESET BREAKPOINT', 'PLAY', and 'SHOW TAGS' buttons. At the bottom is a table with columns: #, Enabled, Index, Description, Period (ms), If condition 1, If condition 2, If condition 3, Then action 1, Then action 2, Then action 3, Else action 1, Else action 2, Else action 3, Condition Status, and Breakpoint. The table currently shows one row with 'No rule' in the Description column.

Let us now create the first rule to calculate the circumference using the largest radius between Radius1 and Radius2:

We need the rule to be performed every 1000 ms:

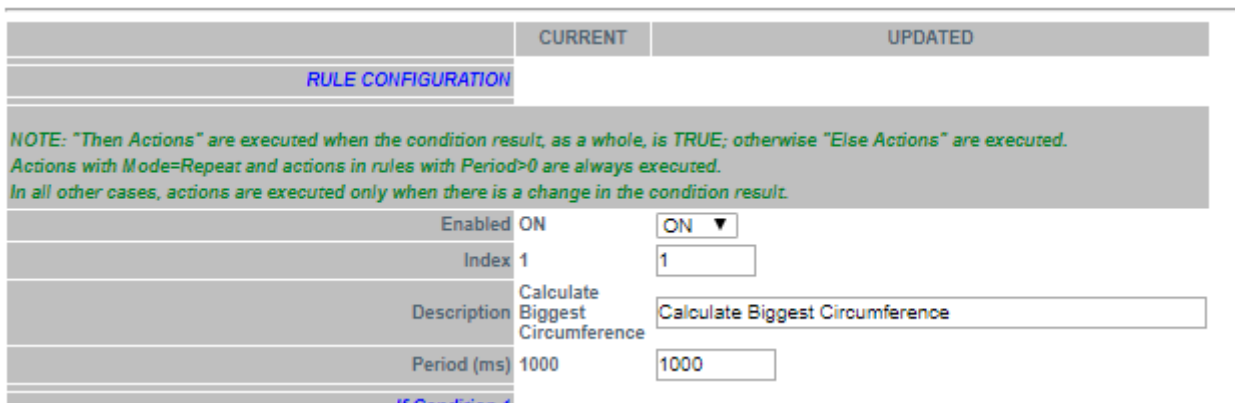

The screenshot shows the 'Rule Configuration' form. It has tabs for 'CURRENT' and 'UPDATED'. A note states: "NOTE: 'Then Actions' are executed when the condition result, as a whole, is TRUE; otherwise 'Else Actions' are executed. Actions with Mode=Repeat and actions in rules with Period>0 are always executed. In all other cases, actions are executed only when there is a change in the condition result." The form fields are: Enabled (ON), Index (1), Description (Calculate Biggest Circumference), and Period (ms) (1000). Below the form is the 'If Condition 1' section.

Then we add the "if condition" to determine which is the larger radius between the two provided (we only need 1 if condition):

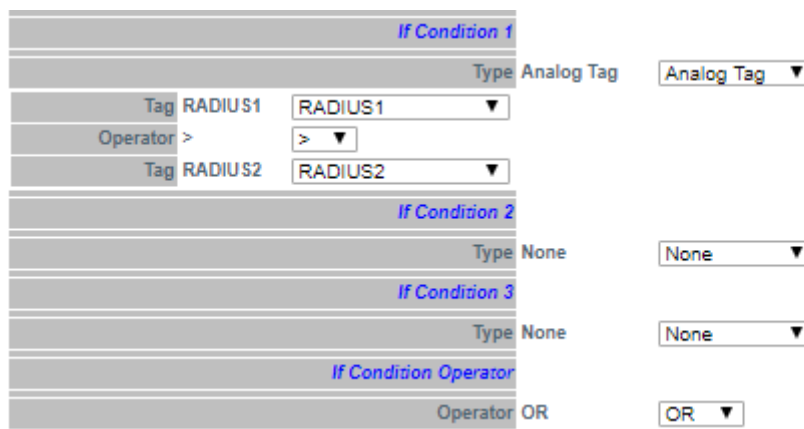

The screenshot shows the 'If Condition 1' configuration. It has a 'Type' dropdown set to 'Analog Tag'. The 'Tag' field is 'RADIUS1' and the 'Operator' is '>'. The 'Tag' field is 'RADIUS2'. Below are 'If Condition 2' and 'If Condition 3' with 'Type' dropdowns set to 'None'. The 'If Condition Operator' is set to 'OR'.

So, if the condition is true then Radius1 > Radius2 we must then calculate the circumference with Radius1:  
 Circumference = Radius1 \* 6.28:

**Then Action 1**

Type: Analog Tag

Action Mode: One time

Destination Tag: CIRCUMFERENCE

Operator: \*

Source Tag 1: RADIUS1

Source Tag 2: constant value

Constant Value 2: 6.28

**Then Action 2**

Type:

**Then Action 3**

Type:

Otherwise Radius 1 < Radius 2 then we must calculate the circumference with Radius 2 (Circumference = Radius2 \* 6.28):

**Else Action 1**

Type: Analog Tag

Action Mode: One time

Destination Tag: CIRCUMFERENCE

Operator: \*

Source Tag 1: RADIUS2

Source Tag 2: constant value

Constant Value 2: 6.28

**Else Action 2**

Type:

**Else Action 3**

Type:

Now click "APPLY" to save the first rule:

#	Enabled	Index	Description	Period (ms)	If condition 1	If condition 2	If condition 3	Then action 1	Then action 2	Then action 3	Else action 1	Else action 2	Else action 3	Condition Status	Breakpoint
1	ON	1	Calculate Biggest Circumference	1000	RADIUS1 > RADIUS2	OR	---	CIRCUMFERENCE = RADIUS1 * 6.28	---	---	CIRCUMFERENCE = RADIUS2 * 6.28	---	---	FALSE	---

In the same way we create the Second Rule to calculate the Area with the largest radius:  
 This rule must also be performed every 1000ms:

	CURRENT	UPDATED
<b>RULE CONFIGURATION</b>		
<p><i>NOTE: "Then Actions" are executed when the condition result, as a whole, is TRUE; otherwise "Else Actions" are executed.</i>  <i>Actions with Mode=Repeat and actions in rules with Period&gt;0 are always executed.</i>  <i>In all other cases, actions are executed only when there is a change in the condition result.</i></p>		
Enabled	ON	<input type="button" value="v"/>
Index	2	<input type="text" value="2"/>
Description	Calculate Biggest Area	<input type="text" value="Calculate Biggest Area"/>
Period (ms)	1000	<input type="text" value="1000"/>

The "if condition" is the same as the first rule:

<b>if Condition 1</b>	
Type	Analog Tag <input type="button" value="v"/>
Tag RADIUS1	<input type="text" value="RADIUS1"/>
Operator >	<input type="button" value="v"/>
Tag RADIUS2	<input type="text" value="RADIUS2"/>
<b>if Condition 2</b>	
Type	None <input type="button" value="v"/>
<b>if Condition 3</b>	
Type	None <input type="button" value="v"/>
<b>if Condition Operator</b>	
Operator	OR <input type="button" value="v"/>

Now we have to calculate the AREA using the following calculation:

$$AREA = ([RADIUS] ^ 2) * 3.14$$

We have to break the formula in two phases:

In the first phase we calculate:

$$AREA = (RADIUS1) ^ 2$$

And in the second:

$$AREA = AREA * 3.14$$

So in our rule if RADIUS1> RADIUS2 we calculate AREA with RADIUS1 using the square function (sqr):

$$AREA = \text{sqr} (RADIUS1)$$

And then

$$AREA = AREA * 3.14$$

**Then Action 1**

Type Analog Tag

Action Mode One time

Destination Tag AREA

Operator  $\sqrt{\quad}$

Source Tag 1 RADIUS1

---

**Then Action 2**

Type Analog Tag

Action Mode One time

Destination Tag AREA

Operator \*

Source Tag 1 AREA

Source Tag 2 constant value

Constant Value 2 3.14

---

**Then Action 3**

Type

So if RADIUS1 < RADIUS2 we calculate AREA with RADIUS2:

**Else Action 1**

Type Analog Tag

Action Mode One time

Destination Tag AREA

Operator  $\sqrt{\quad}$

Source Tag 1 RADIUS2

---

**Else Action 2**

Type Analog Tag

Action Mode One time

Destination Tag AREA

Operator \*

Source Tag 1 AREA

Source Tag 2 constant value

Constant Value 2 3.14

---

**Else Action 3**

Type

**APPLY**

Now click on "APPLY" to save the second rule as well:

#	Enabled	Index	Description	Period (ms)	If condition 1	If condition 2	If condition 3	Then action 1	Then action 2	Then action 3	Else action 1	Else action 2	Else action 3	Condition Status	Breakpoint
1	ON	1	Calculate Biggest Circumference	1000	RADIUS1 > RADIUS2	OR	---	CIRCUMFERENCE = RADIUS1 * 6.28	---	---	CIRCUMFERENCE = RADIUS2 * 6.28	---	---	FALSE	---
2	ON	2	Calculate Biggest Area	1000	RADIUS1 > RADIUS2	OR	---	AREA $\sqrt{\quad}$ RADIUS1	AREA = AREA * 3.14	---	AREA $\sqrt{\quad}$ RADIUS2	AREA = AREA * 3.14	---	FALSE	---

Now we can test how our programme works:

When a rule is added, the rule starts automatically (RUNNING):

The screenshot shows the 'Rule Management' section of the application. Under 'RULE STATUS', the 'Run Status' is 'RUNNING', highlighted in green. Below this are buttons for 'ADD', 'MODIFY', 'COPY', 'MOVE', 'DELETE', and 'DELETE ALL'. A 'Rule Debugger' section contains 'SET/RESET BREAKPOINT', 'PLAY', and 'SHOW TAGS' buttons. At the bottom is a table of rules.

#	Enabled	Index	Description	Period (ms)	If condition 1	If condition 2	If condition 3	Then action 1	Then action 2	Then action 3	Else action 1	Else action 2	Else action 3	Condition Status	Breakpoint
1	ON	1	Calculate Biggest Circumference	1000	RADIUS1 > RADIUS2	OR	---	CIRCUMFERENCE = RADIUS1 * 6.28	---	---	CIRCUMFERENCE = RADIUS2 * 6.28	---	---	FALSE	---
2	ON	2	Calculate Biggest Area	1000	RADIUS1 > RADIUS2	OR	---	AREA sqr RADIUS1	AREA = AREA * 3.14	---	AREA sqr RADIUS2	AREA = AREA * 3.14	---	FALSE	---

To test the program we can write the tags RADIUS1 and RADIUS2 from Modbus RTU / MODBUS TCP-IP (registers 40100-40101 in our example) or using the "Tag View" page:

The screenshot shows the 'Tag View' page with a list of tags. The 'RADIUS1' and 'RADIUS2' entries are highlighted with a red box. A red arrow points to the 'CHANGE' button for RADIUS1.

Index	Tag Name	Register	Register Address	Register Type	Bit	Value	Unit	Scale	Offset	Refresh	Change
17	GPS_YEAR	HOLDING REGISTER	16	UNSIGNED	16BIT	0	-	---	NONE	NONE	
18	GPS_LATITUDE	HOLDING REGISTER	17	REAL	64BIT	0	-	---	NONE	NONE	
19	GPS_LONGITUDE	HOLDING REGISTER	21	REAL	64BIT	0	-	---	NONE	NONE	
20	GPS_HDOP	HOLDING REGISTER	25	REAL	64BIT	0	-	---	NONE	NONE	
21	GPS_ALTITUDE	HOLDING REGISTER	29	REAL	64BIT	0	-	---	NONE	NONE	
22	GPS_COG	HOLDING REGISTER	33	REAL	64BIT	0	-	---	NONE	NONE	
23	GPS_SPEED_KM	HOLDING REGISTER	37	REAL	64BIT	0	-	---	NONE	NONE	
24	GPS_SPEED_KN	HOLDING REGISTER	41	REAL	64BIT	0	-	---	NONE	NONE	
25	GPS_FIX	HOLDING REGISTER	45	UNSIGNED	16BIT	0	-	---	NONE	NONE	
26	GPS_NUM_SAT	HOLDING REGISTER	46	UNSIGNED	16BIT	0	-	---	NONE	NONE	
27	RADIUS1	HOLDING REGISTER	100	SIGNED	16BIT	0	-	07/03/2019 10:07:25.651279	NONE	NONE	CHANGE
28	RADIUS2	HOLDING REGISTER	101	SIGNED	16BIT	0	-	07/03/2019 10:07:25.651519	NONE	NONE	CHANGE
29	CIRCUMFERENCE	HOLDING REGISTER	103	REAL MSW	32BIT	0	-	07/03/2019 11:11:16.130379	NONE	NONE	CHANGE
30	AREA	HOLDING REGISTER	105	REAL MSW	32BIT	0	-	07/03/2019 11:11:16.130488	NONE	NONE	CHANGE

Now change RADIUS1 = 100 and RADIUS2 = 50 by clicking the "CHANGE" button:

192.168.85.103:8080 dice

RADIUS1

OK Annulla

192.168.85.103:8080 dice

RADIUS2

OK Annulla

In the Tag view the CIRCONFERENCE and AREA calculations are updated:

27	RADIUS1	100	HOLDING REGISTER	16BIT SIGNED	100	-	07/03/2019 11:15:56.934313	NONE	NONE	CHANGE
28	RADIUS2	101	HOLDING REGISTER	16BIT SIGNED	50	-	07/03/2019 11:34:12.465220	NONE	NONE	CHANGE
29	CIRCUMFERENCE	103	HOLDING REGISTER	32BIT REAL MSW	628	-	07/03/2019 11:34:39.634836	NONE	NONE	CHANGE
30	AREA	105	HOLDING REGISTER	32BIT REAL MSW	31400	-	07/03/2019 11:34:39.634973	NONE	NONE	CHANGE

Now we can go to the "Rules Management" page to view the result:

		CURRENT	UPDATED
<b>RULE GENERAL CONFIGURATION</b>			
Writing Mode		After execution	After execution
APPLY			
<b>RULE STATUS</b>			
Run Status		RUNNING	
Cycle Time (ms)		0	

Rule Management	ADD	MODIFY	COPY	MOVE	DELETE	DELETE ALL
-----------------	-----	--------	------	------	--------	------------

Rule Debugger	SET/RESET BREAKPOINT	PLAY	SHOW TAGS
---------------	----------------------	------	-----------

  

#	Enabled	Index	Description	Period (ms)	If condition 1	If condition 2	If condition 3	Then action 1	Then action 2	Then action 3	Else action 1	Else action 2	Else action 3	Condition Status	Breakpoint
1	ON	1	Calculate Biggest Circumference	1000	RADIUS1 > RADIUS2	OR	---	CIRCUMFERENCE = RADIUS1 * 6.28	---	---	CIRCUMFERENCE = RADIUS2 * 6.28	---	---	TRUE	---
2	ON	2	Calculate Biggest Area	1000	RADIUS1 > RADIUS2	OR	---	AREA sqrt RADIUS1	AREA = AREA * 3.14	---	AREA sqrt RADIUS2	AREA = AREA * 3.14	---	TRUE	---

So both conditions if they are TRUE (penultimate column) and then "Then actions" are executed.



Now we change the RADIUS2 value in the tag display pages to 200:

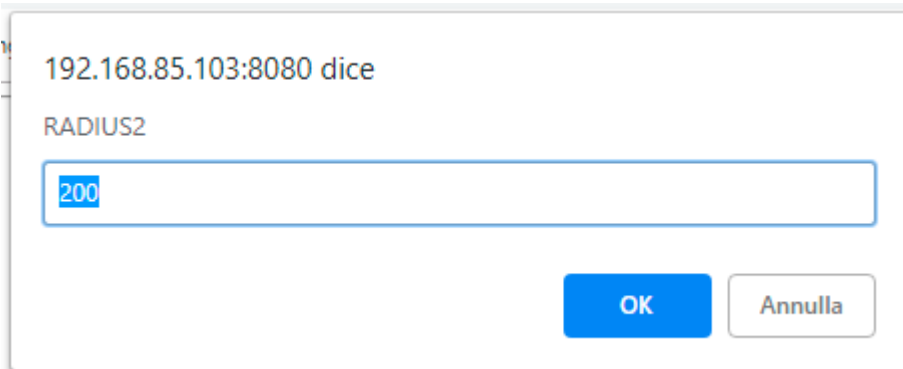

So:

		CURRENT	UPDATED
<b>RULE GENERAL CONFIGURATION</b>			
Writing Mode		After execution	After execution ▼
APPLY			
<b>RULE STATUS</b>			
Run Status		<b>RUNNING</b>	
Cycle Time (ms)		0	

Rule Management	ADD	MODIFY	COPY	MOVE	DELETE	DELETE ALL
-----------------	-----	--------	------	------	--------	------------

Rule Debugger		SET/RESET BREAKPOINT	PLAY	SHOW TAGS
---------------	--	----------------------	------	-----------

#	Enabled	Index	Description	Period (ms)	If condition 1	If condition 2	If condition 3	Then action 1	Then action 2	Then action 3	Else action 1	Else action 2	Else action 3	Condition Status	Breakpoint
1	ON	1	Calculate Biggest Circumference	1000	RADIUS1 > RADIUS2	OR	---	CIRCUMFERENCE = RADIUS1 * 6.28	---	---	CIRCUMFERENCE = RADIUS2 * 6.28	---	---	FALSE	---
2	ON	2	Calculate Biggest Area	1000	RADIUS1 > RADIUS2	OR	---	AREA sqr RADIUS1	AREA = AREA * 3.14	---	AREA sqr RADIUS2	AREA = AREA * 3.14	---	FALSE	---

Now the condition status of the 2 rules is false because RADIUS1 < RADIUS2, so the "Else Actions" are executed

It is also possible to debug the program using the internal rule debugger.

With the internal debugger it is possible:

- Insert a breakpoint before the execution of a rule
- View the tag values before / after the execution of a rule

To add a breakpoint and stop the program flow select the rule and then press "SET / RESET BREAKPOINT":

	CURRENT	UPDATED
<b>RULE GENERAL CONFIGURATION</b>		
Writing Mode	After execution	After execution
APPLY		
<b>RULE STATUS</b>		
Run Status	RUNNING	
Cycle Time (ms)	0	

Rule Management
ADD
MODIFY
COPY
MOVE
DELETE
DELETE ALL

Rule Debugger
SET/RESET BREAKPOINT
PLAY
SHOW TAGS

#	Enabled	Index	Description	Period (ms)	If condition 1	If condition 2	If condition 3	Then action 1	Then action 2	Then action 3	Else action 1	Else action 2	Else action 3	Condition Status	Breakpoint
1	ON	1	Calculate Biggest Circumference	1000	RADIUS1 > RADIUS2	OR	---	CIRCUMFERENCE = RADIUS1 * 6.28	---	---	CIRCUMFERENCE = RADIUS2 * 6.28	---	---	FALSE	---
2	ON	2	Calculate Biggest Area	1000	RADIUS1 > RADIUS2	OR	---	AREA sqr RADIUS1	AREA = AREA * 3.14	---	AREA sqr RADIUS2	AREA = AREA * 3.14	---	FALSE	---

	CURRENT	UPDATED
<b>RULE GENERAL CONFIGURATION</b>		
Writing Mode	After execution	After execution
APPLY		
<b>RULE STATUS</b>		
Run Status	PAUSED	
Cycle Time (ms)	0	

Rule Management
ADD
MODIFY
COPY
MOVE
DELETE
DELETE ALL

Rule Debugger
SET/RESET BREAKPOINT
PLAY
SHOW TAGS

#	Enabled	Index	Description	Period (ms)	If condition 1	If condition 2	If condition 3	Then action 1	Then action 2	Then action 3	Else action 1	Else action 2	Else action 3	Condition Status	Breakpoint
1	ON	1	Calculate Biggest Circumference	1000	RADIUS1 > RADIUS2	OR	---	CIRCUMFERENCE = RADIUS1 * 6.28	---	---	CIRCUMFERENCE = RADIUS2 * 6.28	---	---	FALSE	ON
2	ON	2	Calculate Biggest Area	1000	RADIUS1 > RADIUS2	OR	---	AREA sqr RADIUS1	AREA = AREA * 3.14	---	AREA sqr RADIUS2	AREA = AREA * 3.14	---	FALSE	---

The rule turns yellow and the rule status changes to "Paused". Note that the breakpoint is before the rule execution.

Clicking "Show tags" displays the tag values before the selected rule is executed.

	CURRENT	UPDATED
<b>RULE GENERAL CONFIGURATION</b>		
Writing Mode	After execution	After execution
APPLY		
<b>RULE STATUS</b>		
Run Status	PAUSED	
Cycle Time (ms)	0	

Rule Management
ADD
MODIFY
COPY
MOVE
DELETE
DELETE ALL

Rule Debugger
SET/RESET BREAKPOINT
PLAY
SHOW TAGS

#	Enabled	Index	Description	Period (ms)	If condition 1	If condition 2	If condition 3	Then action 1	Then action 2	Then action 3	Else action 1	Else action 2	Else action 3	Condition Status	Breakpoint
1	ON	1	Calculate Biggest Circumference	1000	RADIUS1 > RADIUS2	OR	---	CIRCUMFERENCE = RADIUS1 * 6.28	---	---	CIRCUMFERENCE = RADIUS2 * 6.28	---	---	FALSE	ON
2	ON	2	Calculate Biggest Area	1000	RADIUS1 > RADIUS2	OR	---	AREA sqr RADIUS1	AREA = AREA * 3.14	---	AREA sqr RADIUS2	AREA = AREA * 3.14	---	FALSE	---

#	TAG NAME	TAG VALUE
1	RADIUS1	100
2	RADIUS2	200
3	CIRCUMFERENCE	1256
4	AREA	125600

Now you can move the breakpoint to the next rule, then select the next rule and press the "SET / RESET BREAKPOINT" button:

Pressing the "PLAY" button will stop the execution before the next rule is executed:

CURRENT		UPDATED	
<b>RULE GENERAL CONFIGURATION</b>			
Writing Mode:	After execution	After execution	
APPLY			
<b>RULE STATUS</b>			
Run Status:	<b>PAUSED</b>		
Cycle Time (ms):	0		
Rule Management		ADD	MODIFY
		COPY	MOVE
		DELETE	DELETE ALL
Rule Debugger		SET/RESET BREAKPOINT	PLAY
		SHOW TAGS	

#	Enabled	Index	Description	Period (ms)	If condition 1	If condition 2	If condition 3	Then action 1	Then action 2	Then action 3	EIse action 1	EIse action 2	EIse action 3	Condition Status	Breakpoint
1	ON	1	Calculate Biggest Circumference	1000	RADIUS1 > RADIUS2	OR	---	CIRCUMFERENCE = RADIUS1 * 6.28	---	---	CIRCUMFERENCE = RADIUS2 * 6.28	---	---	FALSE	---
2	ON	2	Calculate Biggest Area	1000	RADIUS1 > RADIUS2	OR	---	AREA sqr RADIUS1	AREA = AREA * 3.14	---	AREA sqr RADIUS2	AREA = AREA * 3.14	---	FALSE	ON

#	TAG NAME	TAG VALUE
1	RADIUS1	100
2	RADIUS2	200
3	CIRCUMFERENCE	1256
4	AREA	125600

### 13. THE STRATON PLC

The Straton PLC provides full support for the IEC 61131-3 PLC standard; an integrated development environment (IDE) is available for Windows™ PCs.

The Straton IDE includes several tools such as: a fieldbus configuration tool, an analog signal editor and program editors compliant with the five languages of the IEC 61131-3 standard: Sequential Function Chart (SFC), Function Block Diagram (FBD), Ladder Diagram (LD), Structured Text (ST), Instruction List (IL).

With Straton IDE, it's easy to write, download and debug the IEC 61131-3 code.

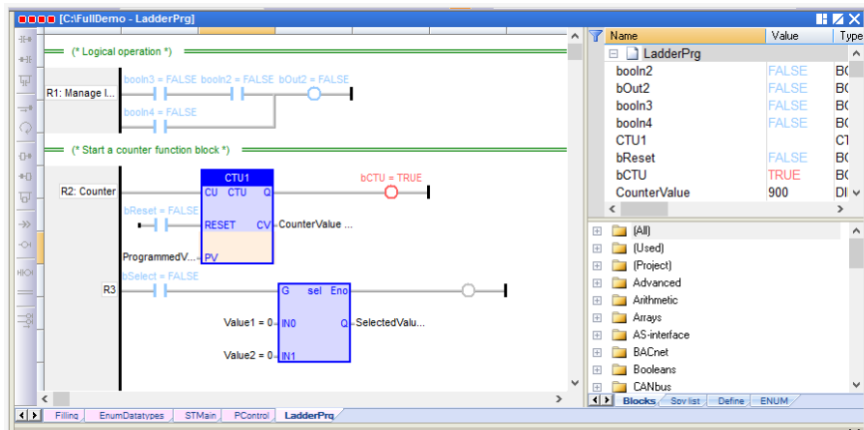

Depending on the model, the device may or may not have the PLC activated by default. By contacting Seneca it is always possible to activate the PLC by entering an activation code.

The PLC directly manages the following protocols: Modbus RTU, Modbus TCP-IP, MQTT, OPC-UA Client, MeterBus (MBUS), S7 Client, SNMP.



To use the MeterBus protocol, it is necessary to purchase the optional Z-MBUS device

For more information, refer to the STRATON PLC manual.

<https://straton-plc.com/en/downloads/>

To allow the PLC developer to easily create Straton applications for Seneca gateways, the following libraries are available:

- a Function Block (FB) and Functions library, which provides some frequently used functions, in particular related to communication and data transfer activities, compiled in the CPU firmware; the direct use of these FBs and functions is aimed at expert PLC developers (a detailed description of the FBs and functions is given in the relevant chapter of this manual);
- a "Profile" library, which allows access to CPU I/OS via "profile" variables
- a "User Defined Function Block" (UDFB) library, in ST language, which simplifies the use of the aforementioned FBs, providing simpler and "higher level" access to their functions.

An installation program called "Seneca Straton Package" is available which automatically installs the Seneca libraries and templates. The installation program also includes Straton IDE and other tools.

The installation program is available at the following link:

<http://www.seneca.it/products/seneca-straton-package>

If, for some reason, the installation program cannot be run, the above libraries and templates can also be installed manually.

The Straton PLC in Seneca gateways can operate in the following modes:

#### ***"NONE" MODE***

The Straton PLC is disabled (default mode for SSD, Z-PASS1-RT, Z-PASS2-RT-4G, R-PASS models)

#### ***"LEGACY (STAND-ALONE)" MODE***

The Straton PLC operates in mode compatible with firmware versions prior to 3000, i.e. the communication protocols are managed only by the PLC (default mode for SSD-S, Z-TWS4-RT-S, Z-PASS2-RT-4G-S, R-PASS-S models).

#### ***"SHARED" MODE***

The Straton PLC operates in shared mode, i.e. the Straton PLC and the firmware communicate with each other via a shared memory on OPC-UA protocol.

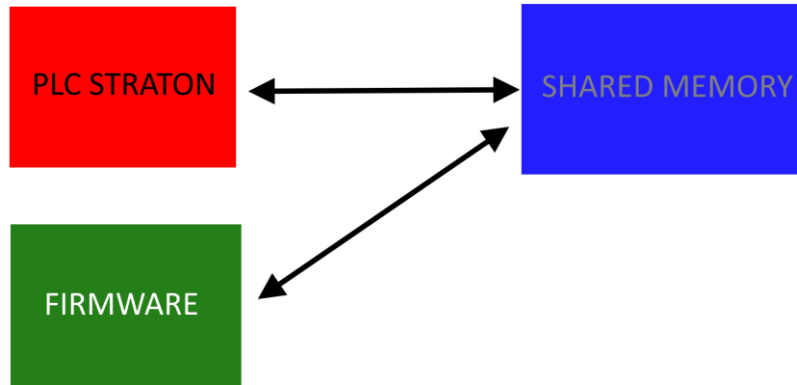

In this mode it is possible to activate the data logger, alarms, display / virtual display and communication protocols already present in the firmware and to read and write the TAGs directly from the PLC.

### 13.1. IMPORTING TAGS INTO THE PLC (PLC MODE = SHARED)

In this chapter we will see how to:

- Create a new Straton PLC project
- Import Tags written by the Gateway firmware on the PLC to be able to read them
- Create Tags written by Straton and be able to read them in the gateway firmware (for example to be displayed on the display synoptics / virtual display).

Run the Straton IDE and create a new project:

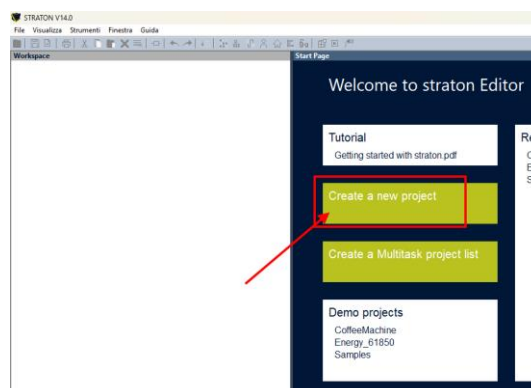

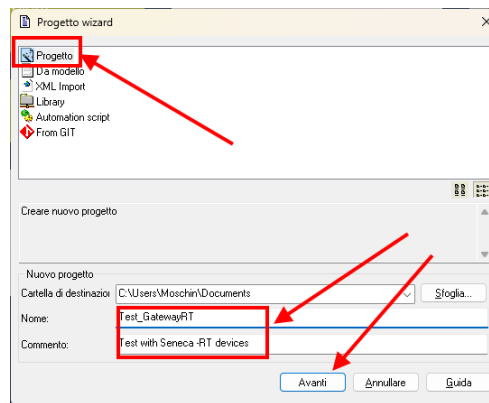

Let's start from an empty project and insert the gateway IP address (in the example 192.168.120.10):

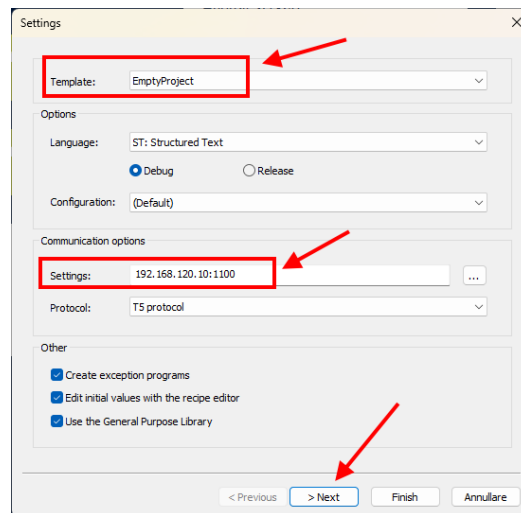

OPC-UA is used as the internal fieldbus for tag exchange, so let's select it and press finish:

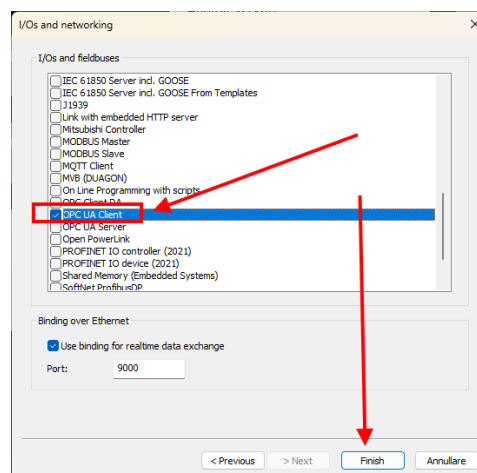

At this point in the fieldbus configuration we will have the OPC-UA client in the IDE:

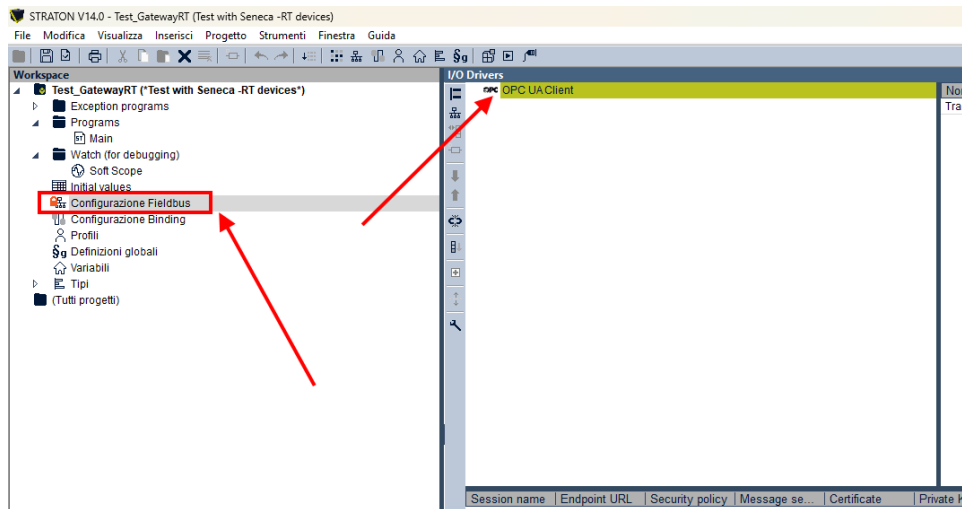

Now we will import the TAGs defined in the gateway to be imported into Straton.  
The import is done simply by performing a TAG scan.

First we insert the OPC-UA master and as the server address the Gateway address (in our case 192.168.120.10):

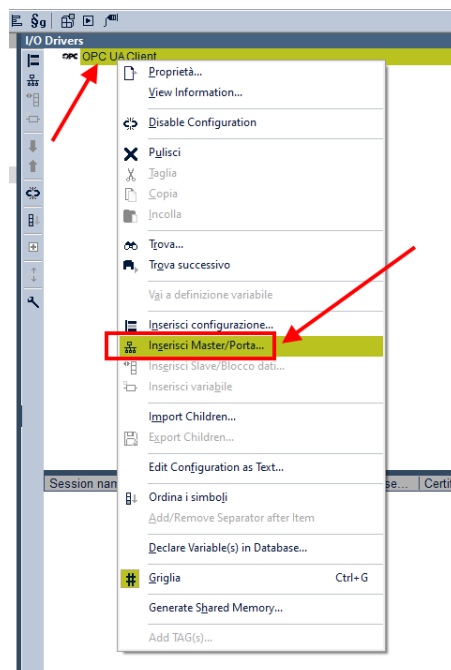

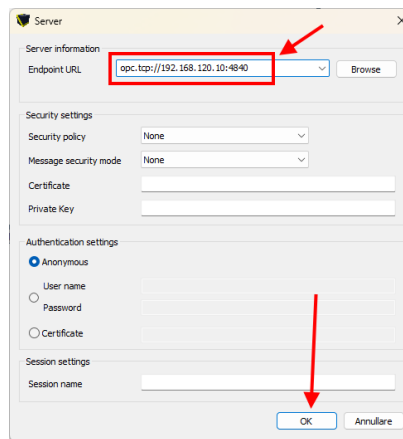

At this point we prepare the data block where the TAGs will be inserted:

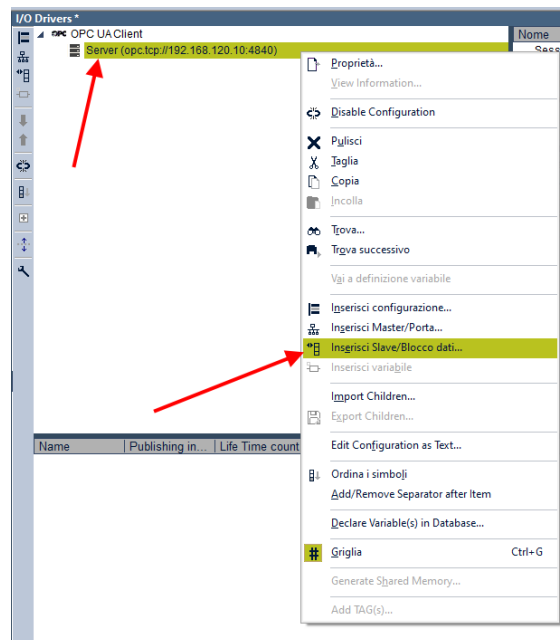

And we call the data group with a name of our choice, in our case TAGS:

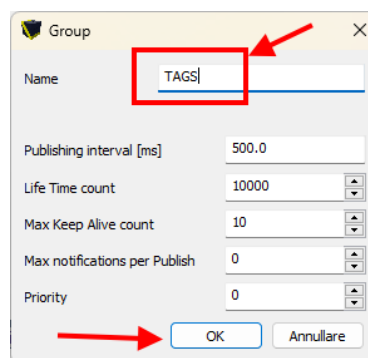

Now we are ready to import the TAGs by clicking on Add TAGS:



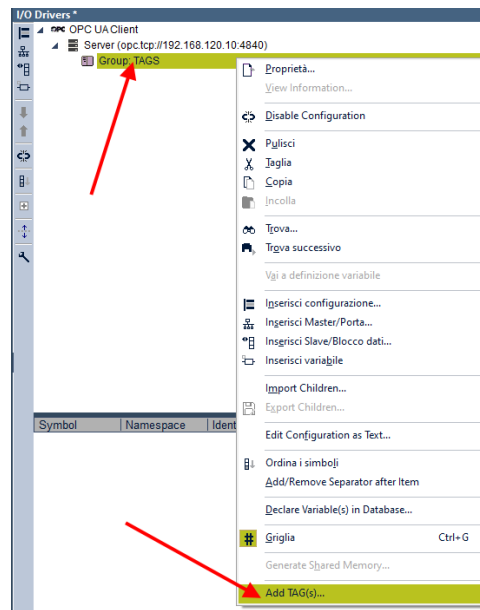

The operation lists all the tags defined by the gateway (including the embedded type Tags). To import them into Straton press the >> icon:

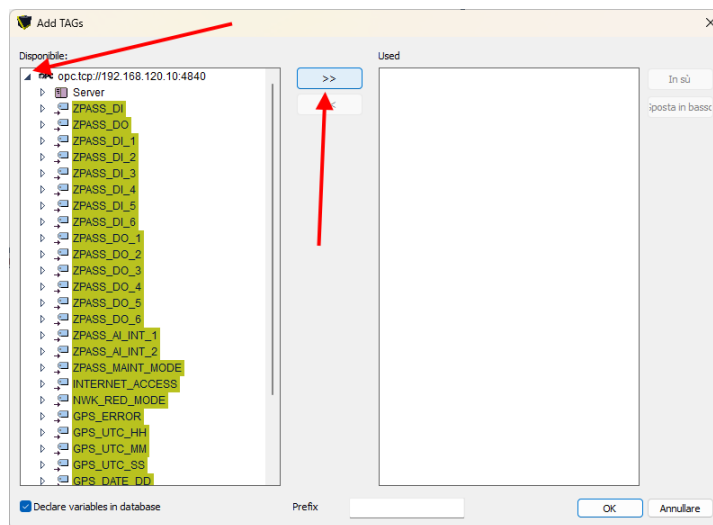

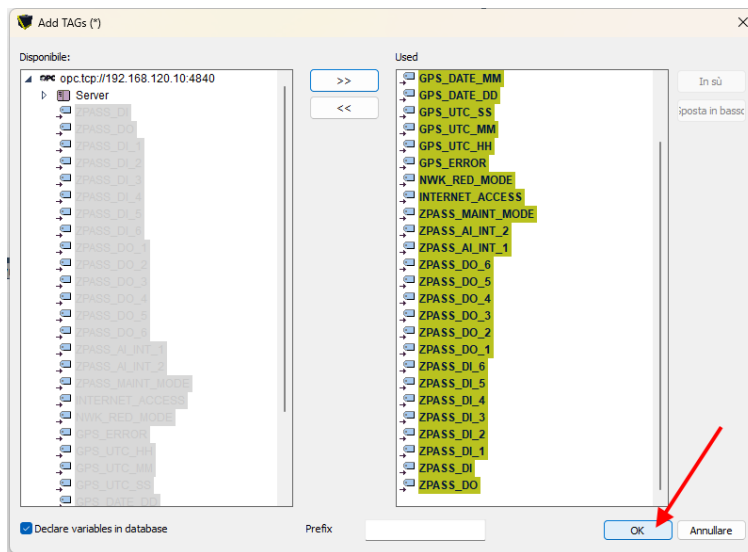

At this point the TAGs are imported into the PLC, note how all are set by default as ReadOnly:

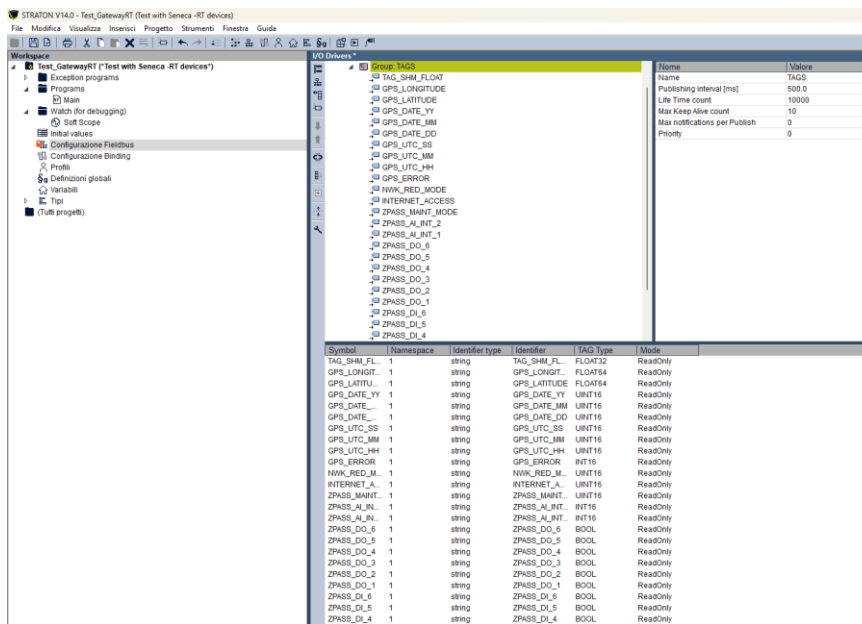

If we want to create a tag that can be written by Straton and displayed for example on the physical or virtual display, we must first create a TAG of the “internal” type in “shared memory” and enable the export to Display/PLC:

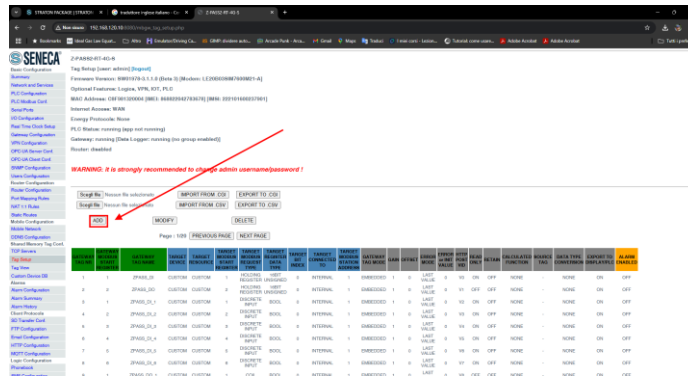

**TAG 30**

CURRENT	UPDATED
GATEWAY TAG NAME	TAG_STRATON
GATEWAY MODBUS START REGISTER ADDRESS	118 <small>Equivalent to address : 40118</small>
TARGET CONNECTED TO	INTERNAL
TARGET MODBUS REQUEST TYPE	HOLDING REGISTER
TARGET REGISTER DATA TYPE	16BIT SIGNED
GATEWAY TAG MODE	SHARED MEMORY
INITIAL VALUE	0
HTTP POST VID	32 <small>Corresponding to HTTP POST variable : V32</small>
READ ONLY	OFF <small>If ON, tag value cannot be changed by means of Modbus protocol</small>
RETAIN	OFF
CALCULATED FUNCTION	NONE
EXPORT TO DISPLAY/PLC	ON <small>If ON, this tag will be available in GUI pages and PLC projects</small>
ALARM ENABLED	OFF <small>This parameter can be changed in "Alarm Configuration" page</small>

APPLY

The new tag appears on the Tag view page.

30	118	TAG_STRATON	-	-	-	HOLDING REGISTER	16BIT SIGNED	0	INTERNAL	-	SHARED-MEMORY	1	0	ERROR VALUE	0	V32	OFF	OFF	NONE	-	NONE	ON	OFF
----	-----	-------------	---	---	---	------------------	--------------	---	----------	---	---------------	---	---	-------------	---	-----	-----	-----	------	---	------	----	-----

Now we return to Straton and import the new tag with the "Add Tags" option:

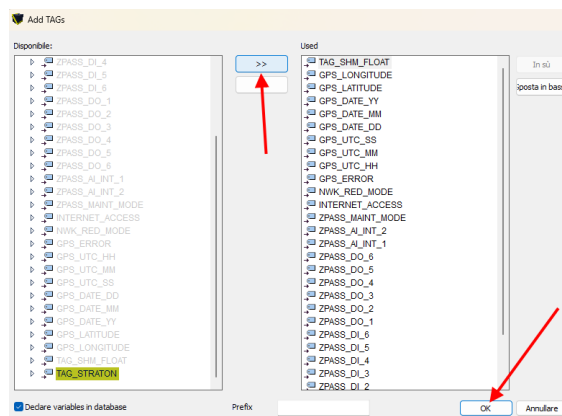

Since we want to write the Tag from Straton, we set it to write:

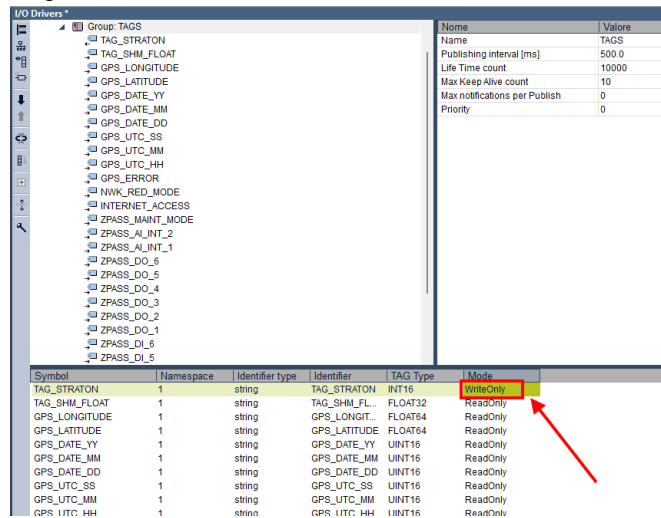

We compile:

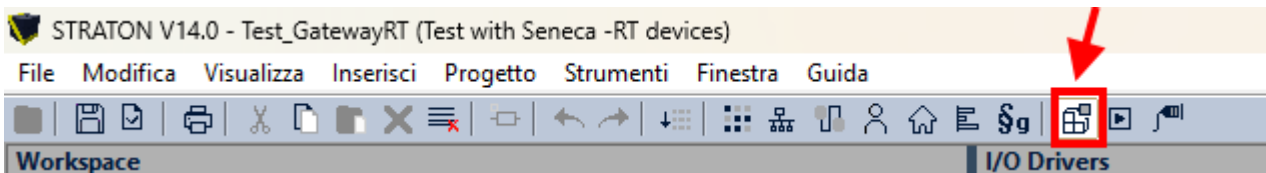

And send the Project to the target:

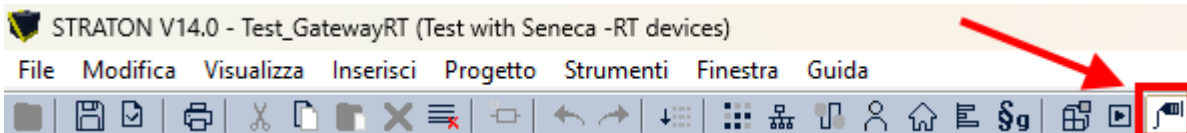

Now if the TAG is written by Straton, we see the effect on the tag view of the web server:

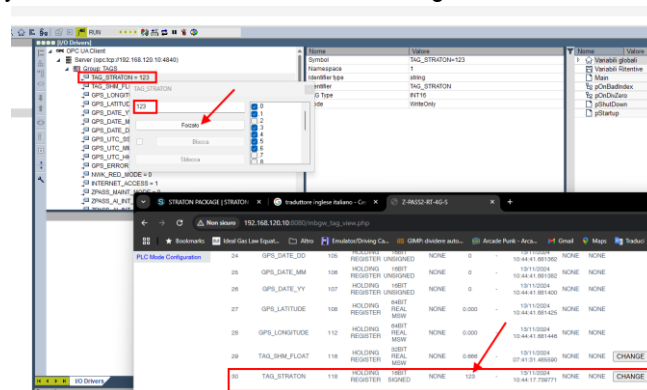

Now we write an embedded I/O from Straton, we change the TAG for example of DO2 in WriteOnly:

Symbol	Namespace	Identifier type	Identifier	TAG Type	Mode
ZPASS_MAINT_MODE	1	string	ZPASS_MAINT...	UINT16	ReadOnly
ZPASS_AI_INT_2	1	string	ZPASS_AI_INT...	INT16	ReadOnly
ZPASS_AI_INT_1	1	string	ZPASS_AI_INT...	INT16	ReadOnly
ZPASS_DO_6	1	string	ZPASS_DO_6	BOOL	ReadOnly
ZPASS_DO_5	1	string	ZPASS_DO_5	BOOL	ReadOnly
ZPASS_DO_4	1	string	ZPASS_DO_4	BOOL	ReadOnly
ZPASS_DO_3	1	string	ZPASS_DO_3	BOOL	ReadOnly
ZPASS_DO_2	1	string	ZPASS_DO_2	BOOL	WriteOnly
ZPASS_DI_1	1	string	ZPASS_DI_1	BOOL	ReadOnly
ZPASS_DI_6	1	string	ZPASS_DI_6	BOOL	ReadOnly
ZPASS_DI_5	1	string	ZPASS_DI_5	BOOL	ReadOnly
ZPASS_DI_4	1	string	ZPASS_DI_4	BOOL	ReadOnly
ZPASS_DI_3	1	string	ZPASS_DI_3	BOOL	ReadOnly
ZPASS_DI_2	1	string	ZPASS_DI_2	BOOL	ReadOnly
ZPASS_DI_1	1	string	ZPASS_DI_1	BOOL	ReadOnly
ZPASS_DI	1	string	ZPASS_DI	UINT16	ReadOnly
ZPASS_DO	1	string	ZPASS_DO	UINT16	ReadOnly

We compile and send the project.

If we force the TAG from Straton, we see the effect on the web page (and on the device LED):

Beware that this TAG is write-only on Straton, so it is not possible to write it for example from logical rules.

## 14. SCRIPT EXECUTION IN LOGICAL RULES

Devices allow you to execute scripts as Then/Else actions in logical rules.



Scripts are a very powerful tool and as such can modify the proper operation of the device. It is the user's responsibility to verify that this does not happen. It is also necessary to verify that the script

does not allow modification of the cybersecurity of the device, for example by opening sockets that are not foreseen.

## 14.1. Reading and writing a Tag from a script

Reading and writing a tag from a script are performed using the commands: “tag\_read” and “tag\_write”.

### 14.1.1.Tag\_read

The tag\_read command allows you to read the value of a tag.  
The syntax is as follows:

```
tag_read <tag_name>
```

returns:

```
<res>;<tag_value>;<is_valid>
```

Where:

<res>

It may be:

0: success

-1: invalid argument

-2: operation failed

<tag\_value>

It is the value of the tag in string format

<is\_valid>

0: the value of the tag is in fail

1: the value of the tag is valid

example:

```
tag_read TAG_SHM_CNT
```

returns:

```
0;172;1
```

It means that the tag exists, the tag value is 172 and the tag is not failing

#### 14.1.2. Tag\_write

Using the tag\_write command you can write a tag.  
The syntax is as follows:

```
tag_write <tag_name> <tag_value>
```

returns:

```
<res>
```

```
0: success
```

```
-1: invalid arguments
```

```
-2: operation failed
```

Example:

```
tag_write TAG_SHM_CNT 173
```

returns

```
0
```

It means that the tag exists, the write operation was successful.

## 14.2. EXAMPLE OF A PYTHON SCRIPT

The following script reads the value of the tag "TAG\_SHM\_CNT" increases it by 1 and rewrites the new value in the same tag. For further information, see link:

[https://www.w3schools.com/python/python\\_intro.asp](https://www.w3schools.com/python/python_intro.asp)

```
from subprocess import run
```

```
tag_read_prog = "/disk/bin/tag_read"
```

```
tag_write_prog = "/disk/bin/tag_write"
```

```
tag_name="TAG_SHM_CNT"
```

```
read_cmd = tag_read_prog + " " + tag_name
```

```
data = run(read_cmd, capture_output=True, shell=True, text=True) #read the tag
```

```
out_str = data.stdout
```

```
res_str = out_str.rstrip() # strip trailing newline character
```

```

res = res_str.split(";")
if res[0] == "0":
    print("tag_read success !")
    print("tag_value: " + res[1])
    print("tag_valid: " + res[2])
    val = int(res[1])
    read_ok = True
else:
    print("tag_read failure !")
    read_ok = False

if read_ok == True:
    new_val = val + 1 # increment by 1
    write_cmd = tag_write_prog + " " + tag_name + " " + str(new_val)
    data = run(write_cmd, capture_output=True, shell=True, text=True) #write the tag
    out_str = data.stdout
    res = out_str.strip() # strip strailing newline character
    if res == "0":
        print("tag_write success !")
    else:
        print("tag_write failure !")

```

### 14.3. PYTHON MODULES INSTALLED

<code>__future__</code>	<code>_threading_local</code>	<code>grp</code>	<code>secrets</code>
<code>_abc</code>	<code>_tracemalloc</code>	<code>gzip</code>	<code>select</code>
<code>_ast</code>	<code>_uuid</code>	<code>hashlib</code>	<code>selectors</code>
<code>_asyncio</code>	<code>_warnings</code>	<code>heapq</code>	<code>shelve</code>
<code>_bisect</code>	<code>_weakref</code>	<code>hmac</code>	<code>shlex</code>
<code>_blake2</code>	<code>_weakrefset</code>	<code>html</code>	<code>shutil</code>
<code>_bootlocale</code>	<code>_xxtestfuzz</code>	<code>http</code>	<code>signal</code>
<code>_bz2</code>	<code>abc</code>	<code>idlelib</code>	<code>site</code>
<code>_codecs</code>	<code>aifc</code>	<code>imaplib</code>	<code>smtpd</code>
<code>_codecs_cn</code>	<code>antigravity</code>	<code>imghdr</code>	<code>smtplib</code>
<code>_codecs_hk</code>	<code>argparse</code>	<code>imp</code>	<code>sndhdr</code>
<code>_codecs_iso2022</code>	<code>array</code>	<code>importlib</code>	<code>socket</code>
<code>_codecs_jp</code>	<code>ast</code>	<code>inspect</code>	<code>socketserver</code>
<code>_codecs_kr</code>	<code>asynchat</code>	<code>io</code>	<code>spwd</code>
<code>_codecs_tw</code>	<code>asyncio</code>	<code>ipaddress</code>	<code>sqlite3</code>
<code>_collections</code>	<code>asyncore</code>	<code>itertools</code>	<code>sre_compile</code>



_collections_abc	atexit	json	sre_constants
_compat_pickle	audioop	keyword	sre_parse
_compression	base64	ldb	ssl
_contextvars	bdb	lib2to3	stat
_crypt	binascii	linecache	statistics
_csv	binhex	locale	string
_ctypes	bisect	logging	stringprep
_ctypes_test	builtins	lzma	struct
_curses	bz2	macpath	subprocess
_curses_panel	cProfile	mailbox	sunau
_datetime	calendar	mailcap	symbol
_dbm	cgi	marshal	symtable
_decimal	cgitb	math	sys
_dummy_thread	chunk	mimetypes	sysconfig
_elementtree	cmath	mmap	syslog
_functools	cmd	modulefinder	tabnanny
_hashlib	code	multiprocessing	talloc
_heapq	codecs	netrc	tarfile
_imp	codeop	nis	tdb
_io	collections	nntplib	telnetlib
_json	colorsys	ntpath	tempfile
_ldb_text	compileall	nturl2path	termios
_locale	concurrent	numbers	textwrap
_lsprof	configparser	opcode	this
_lzma	contextlib	operator	threading
_markupbase	contextvars	optparse	time
_md5	copy	os	timeit
_multibytecodec	copyreg	ossaudiodev	tkinter
_multiprocessing	crypt	parser	token
_opcode	csv	pathlib	tokenize
_operator	ctypes	pdb	trace
_osx_support	curses	pickle	traceback
_pickle	dataclasses	pickletools	tracemalloc
_posixsubprocess	datetime	pipes	tty
_py_abc	dbm	pkgutil	turtle
_pydecimal	decimal	platform	turtledemo
_pyio	difflib	plistlib	types
_queue	dis	poplib	typing
_random	distutils	posix	unicodedata
_sha1	doctest	posixpath	unittest
_sha256	dummy_threading	pprint	urllib
_sha3	email	profile	uu

_sha512	encodings	pstats	uuid		
_signal	ensurepip	pty	venv		
_sitebuiltins	enum	pwd	warnings		
_socket	errno	py_compile	wave		
_sqlite3	faulthandler	pyclbr	weakref		
_sre	fcntl	pydoc	webbrowser		
_ssl	filecmp	pydoc_data	wsgiref		
_stat	fileinput	pyexpat	xdrlib		
_string	fnmatch	queue	xml		
_strptime	formatter	quopri	xmlrpc		
_struct	fractions	random	xxlimited		
_symtable	ftplib	re	xxsubtype		
_sysconfigdata_m_linux_arm-linux-gnueabi	functools	readline	zipapp		
_tdb_text	gc	reprlib	zipfile		
_testbuffer	genericpath	resource	zipimport		
_testcapi	getopt	rlcompleter	zlib		
_testimportmultiple	getpass	runpy			
_testmultiphase	gettext	samba			
_thread	glob	sched			

## 15. ENERGY PROTOCOLS FOR THE STRATON PLC

In the devices it is possible to activate (together with the Straton PLC) other additional protocols related to energy management, it is possible to activate:

- IEC61850 Server
- IEC61850 Client
- IEC60870-5-104 Server
- IEC60870-5-104 Client
- IEC60870-5-101 Master
- IEC60850-5-101 Slave



IEC 61850 is a standard for the design of automation systems for electrical substations. It is part of the International Electrotechnical Commission.

IEC 60870 Part 5 is one of the IEC 60870 standards that define systems used for telecontrol (supervisory control and data acquisition) in electrical engineering and power system automation applications. Part 5 provides a communication profile for sending basic telecontrol messages between two systems, which uses permanent data circuits directly connected between the systems.

IEC 60870-5-104 (aka IEC 104 or Protocol 104) has a TCP/IP-based data transmission mode, IEC 60870-5-101 (aka IEC 101 or Protocol 101) has a serial-based data transmission mode.

For more information, refer to the STRATON PLC manual.

<https://straton-plc.com/en/downloads/>

## 16. MANUAL INSTALLATION OF LIBRARIES IN STRATON

The following steps are required to integrate the libraries into the Straton IDE in case you do not want to use the Straton package software.

First, we need to add the Seneca FB library (SenecaStratonLibrary.XL5 file) to the IDE, using the "Library Manager" tool:

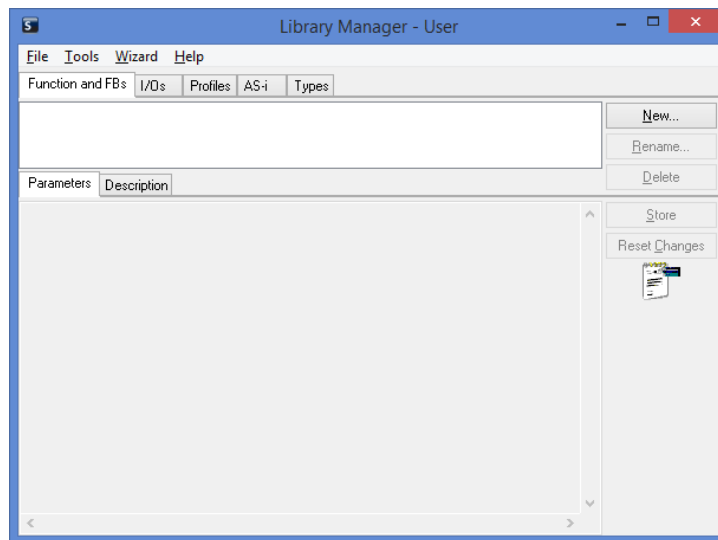

Select the "File / Open Library" option and enter the name "Seneca" to create the new Seneca library.

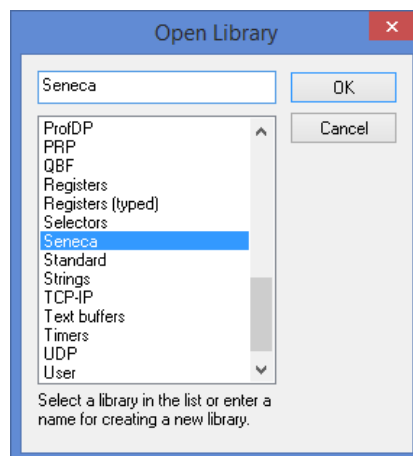

Then, import the Library (“Tools / Import” menu):

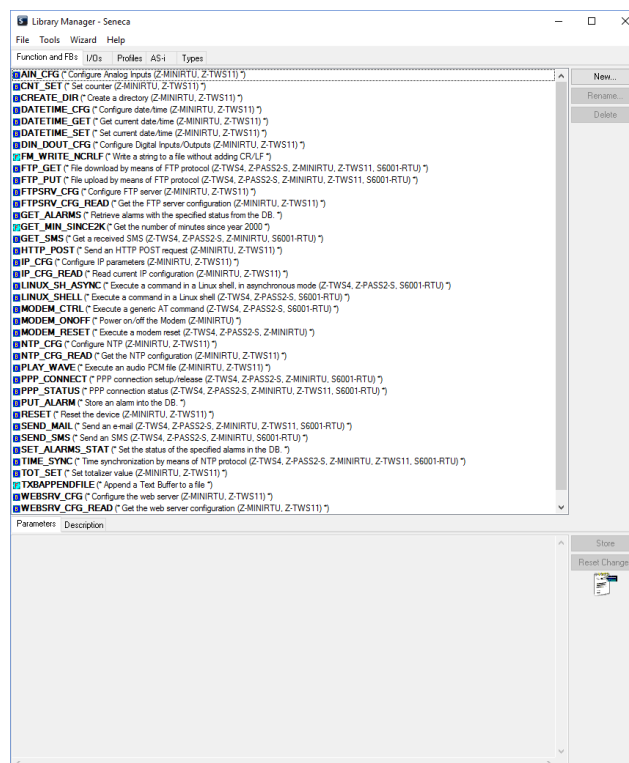
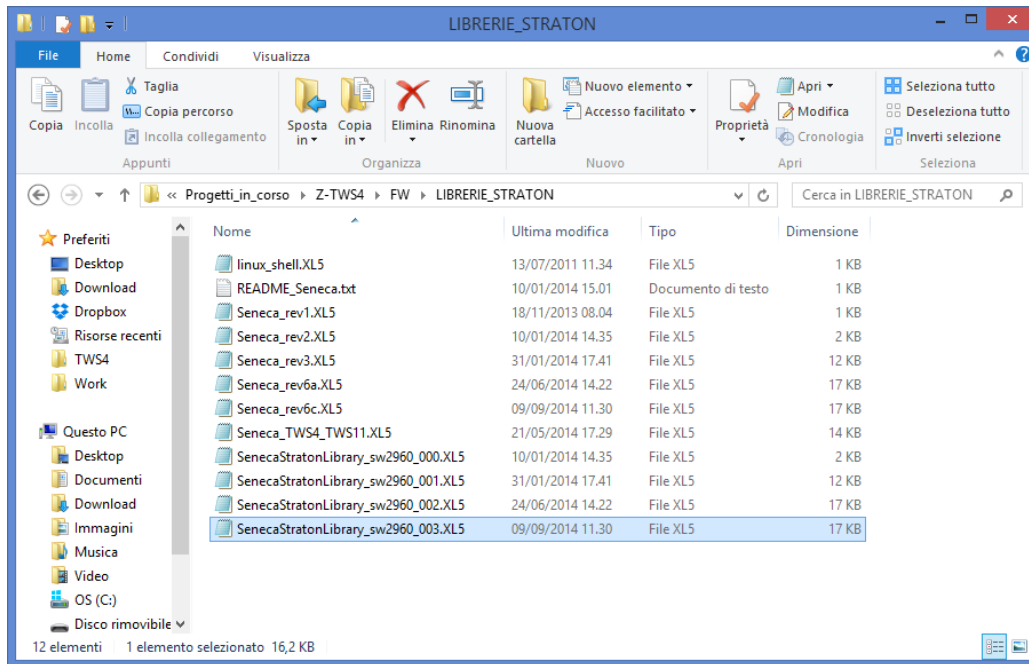

Save the library (“File / Save Library” menu).

Now that the "low level" FBs are available, we need to install the UDFB library.

The UDFB library is provided as a zip file.

The TWS\_MISC folder, contained in the zip file, must be copied to the following directory:  
*C:\Users\Public\Documents\Copalp\STRATON\LIBS:*

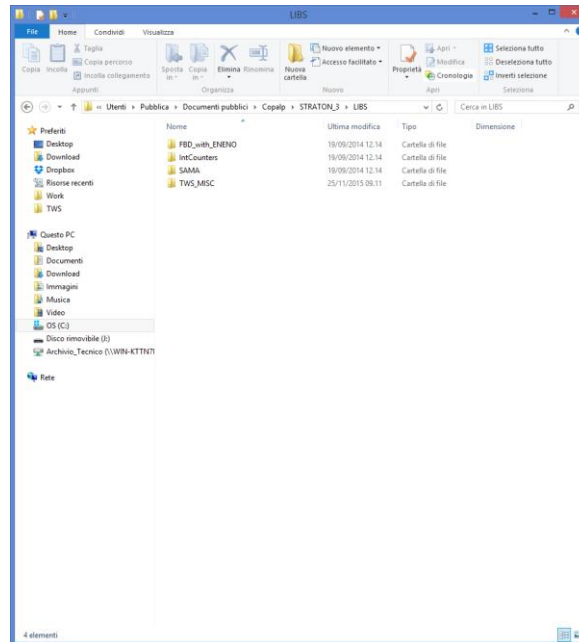

The template folders must be copied to the following directory:  
*C:\Users\Public\Documents\Copalp\STRATON\Template*

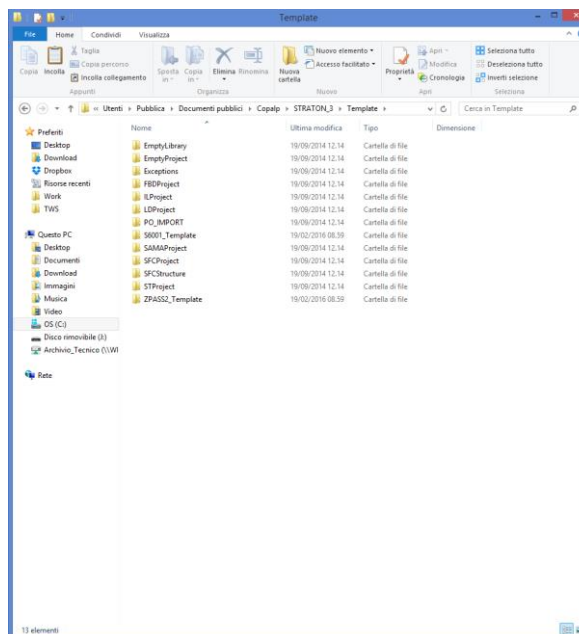

## 17. CYBERSECURITY

Seneca IIOT Gateway devices are regularly subjected to severe tests by third-party companies, in order to verify the effectiveness of data protection systems and unauthorized access by an external attacker. Continuous monitoring allows greater control over all firmware that is gradually released.



## 18. WRITING FROM CLOUD TO DEVICE

### 18.1. WRITING TAGS FROM CLOUD TO DEVICE VIA MQTT

Tags can be written via MQTT in two basic ways.

In the first, the tag name does not appear in the payload, in the second, the tag name is made explicit in the payload.

To write a tag without making its name explicit in the payload, you must subscribe to the topic:

*seneca/Z-PASS MQTT Client/info/#*

A publish with topic will then be received from the device:

*seneca/Z-PASS MQTT Client/info/<nome tag>*

and payload.

*{"val": <valore tag>}*

or

*{"value": <valore tag>}*

for example:

making the publish to the topic:

*seneca/Z-PASS MQTT Client/info/Pippo*

with payload:

```
{"val": 1234}
```

The decimal value 1234 is written in the Tag named "Pippo" (be careful with case sensitivity).

To write a tag explicitly stating the name in the payload, you need to subscribe to the topic:

*seneca/Z-PASS MQTT Client/info*

A publish with topic will then be received from the device:

*seneca/Z-PASS MQTT Client/info*

and payload.

```
{"tags": [{"<nome tag>": <valore tag>]}
```

for example:

```
{"tags": [{"Pippo_fp": 123.46}]}
```

Writes the floating point value 123.46 in the tag "Pippo\_fp"

Or it is possible instead of defining the tag name to use the ID (number that appears in the Tag Vid column (see Tag setup configuration web page):

```
{"tags_id": [{"<(vid+1)>": <valore tag>]}
```

for example:

```
{"tags_id": [{"25": 789}]}
```

Writes in the tag with vid = 24 the decimal integer value 789



It is also possible to write more than one tag at the same time with the syntaxes:

```
{"tags": [{"<nome tag1>": <valore tag1>}, {"<nome tag2>": <valore tag2>},.... ] }
```

Or:

```
{"tags_id": [{"(vid tag1)+1": <valore tag1>}, {"(vid tag2)+1": <valore tag2>},.... ] }
```

for example:

```
{"tags": [{"Pippo": 1234}, {"Pippo_fp": 123.46}]}
```

```
{"tags_id": [{"25": 1234}, {"26": 123.46}]}
```

They write both tags at the same time.

## 18.2. SENDING ACTION COMMANDS FROM THE CLOUD TO THE DEVICE VIA MQTT

To send commands to the device via MQTT, the device must receive a PUBLISH, like this:

```
seneca/Z-PASS MQTT Client/info  
{"act": 1}
```

where:

```
seneca/Z-PASS MQTT Client/info
```

is the value of the “Subscribe Topic” parameter of the “MQTT Configuration” webserver configuration page.

The possible “actions” are:

<b>ACT</b>	<b>COMMAND</b>
1	Restarts the device
2	Makes the device save the configuration in the URL defined by the parameter “Save Configuration URL” Defined in the configuration webserver page “MQTT Configuration”.
3	Reads the configuration from the URL defined in

	the “Load Configuration URL” parameter Defined in the “MQTT Configuration” configuration web server page.
4	Downloads the firmware contained in the URL defined by the parameter “FW Update URL” Defined in the “MQTT Configuration” configuration web server page and performs the update.
5	Enables the VPN BOX 2 feature and also activates the mobile network data connection.
6	Enables the VPN BOX 2 function
7	Disables the VPN BOX 2 function
8	Enables the OPEN VPN function
9	Disables the OPEN VPN function
10	Deletes the Data logger files (equivalent to pressing the “Clean Cache” button on the “tag view” configuration web server page.

## 19. SFTP ACCESS

To easily access the device via SFTP, you can for example use the WINSCP program; you can download WINSCP for free from:

<http://winscp.net/eng/download.php>

Set the connection as in the following figure (the screen shows a connection to IP address 192.168.85.103):

The credentials (username and password) are those ("user", "123456") set for "FTP USER".

After clicking on the "Login" button, a new window will appear, as in the following screen; on the right you can copy and delete files directly on / from the device.

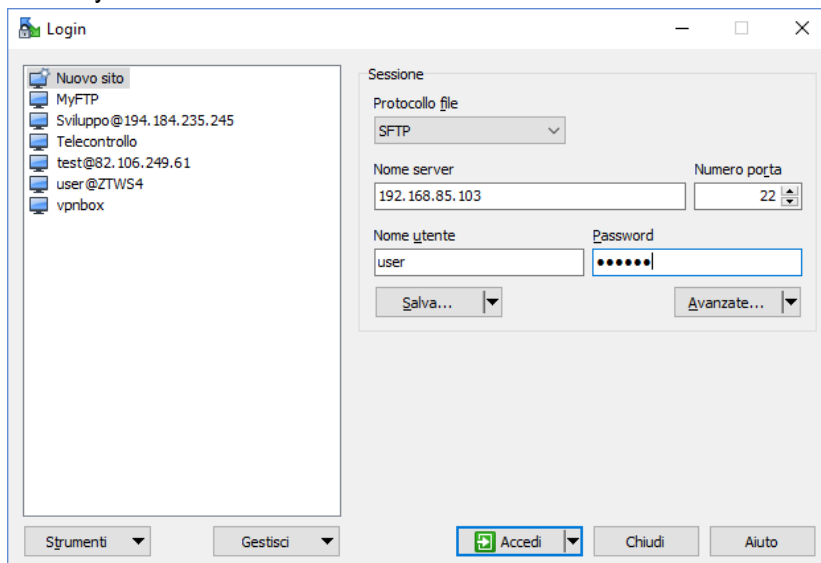

The WinSCP program is used to transfer files from/to the device.

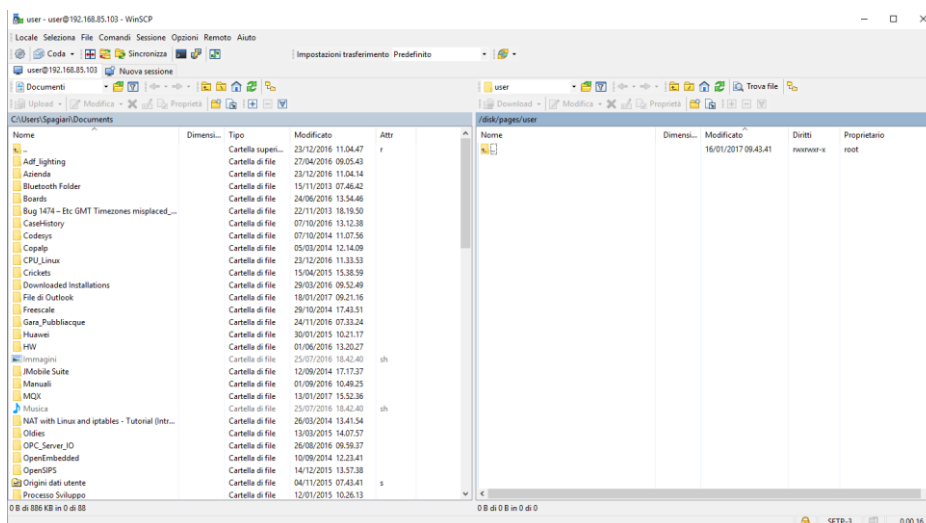



## 20. MAINTENANCE MODE

The maintenance mode can be activated via webserver or via modbus tcp-ip/RTU.

In maintenance mode, tags cannot be written via the physical or virtual display but only via protocols (ethernet and serial).

To enable the "maintenance mode" set the value of the "Maintenance Mode" register to 1.

## 21. SMS COMMANDS

On devices with a mobile modem, a number of functions can be controlled using "SMS commands"; these include setting up a mobile data connection (PPP), activating the VPN Box 2 feature, setting up a digital output, etc.

SMS commands can be sent via the phone numbers in the device's Address Book as "admin" or "manager" users; alternatively, any phone number can send an SMS command, provided that the command contains a "password"; the password is the last four digits of the modem's IMEI; therefore, the command will have the following format (there must be a blank space between the "password" and the command text):

```
<last four IMEI digits> <command text>
```

Example:

```
6172 PPP ON
```

Please note that the command text can be all uppercase, all lowercase, or a combination of these characters.

Any SMS command received from a number not recognized as the "admin" or "manager" user and not containing the password will be ignored; optionally, these messages and all messages not recognized as valid commands can be "relayed" to the "admin" user.

Example:

```
PPP ON RELAYED
```

SMS commands fall broadly into two categories:

"set" commands that perform an action

"get" commands that request some information

While "get" commands always have a response, "set commands" may or may not be acknowledged, depending on the configuration parameter.

Any response to a command, be it "set" or "get," will contain the text of the original message plus a result string, for example:

"EXECUTING"

to indicate that the command has been processed successfully; the "ING" form is used to indicate that the procedure started with the command may not have been completed yet

"FAILED"

to indicate that the command could not be processed or something went wrong; in this case there is an error string that provides the reason for the failure

Examples:

```
PPP ON EXECUTING (100.70.179.88)
```

```
PPP ON FAILED (System PPP ON)
```

Of course, the response to a “get” command also contains the requested information, if the command was processed successfully.

Example:

```
GET DIN EXECUTING (1,0,0,0)
```

Finally, you can disable the entire SMS command function if not needed via a configuration parameter. The following paragraphs provide a complete list of supported commands along with their corresponding responses.

## 21.1. PPP ON

This command can be used to configure the mobile data connection (PPP); the connection is configured with the system configuration parameters (APN Mode, APN, Auth Type, etc.).

If the command is processed correctly, the response contains the IP address assigned to the PPP network interface.

This command is rejected in the following case:

- if the “Remote Connection Disable” (RCD) digital input is HIGH and the “Security Level/Service Disable” parameter is set to “Internet Connection”, the command will fail and generate the “Security Level error”.

Furthermore, if the connection configuration procedure is not completed after the timeout period (currently set to 30 seconds), the command will fail and generate the “Timeout error”.

Please note that failure to activate the mobile data connection with this command is permanent; therefore, if the device is rebooted, the mobile data connection (PPP) will not be re-established.

Example:

```
→ PPP ON
```

```
← PPP ON EXECUTING (100.70.179.88)
```

## 21.2. PPP OFF

This command can be used to disable the mobile data connection (PPP) set with a previous “PPP ON” command.

Please note that this command does not disable the mobile data connection permanently; therefore, if the device is rebooted, the mobile data connection (PPP) will not be reestablished.

This command is never rejected.

Example:

```
→ PPP OFF
← PPP OFF EXECUTING
```

### 21.3. PPP IP

This command can be used to get the IP address assigned to the mobile data connection (PPP); if the PPP connection is not active, the “dummy” IP address (0.0.0.0) will be shown.

This command is never rejected.

Example:

```
→ PPP IP
← PPP IP EXECUTING (100.70.179.88)
```

## 21.4. PPP CNF

This command can be used to change the value of the system configuration parameters related to mobile data connection (PPP); the changes are permanent.

The command will have the following format and the parameter values must be separated by a blank space:

```
PPP CNF <APN mode> <APN> <Authentication Type> <Username> <Password> <PPP Connection  
Testing IP Address>
```

All parameters must be present in the above order; no parameter can be left empty.

Regarding the meaning of these parameters: <APN> and <Authentication Type> are numeric fields with the following values:

APN Mode

```
0:   Automatic  
1:   Manual
```

Authentication Type

```
0:   None  
1:   CHAP/PAP  
2:   CHAP only  
3:   PAP only
```

This command is rejected in the following case:

If any of the command parameters is missing or invalid, the command will fail, resulting in the error “Command parameter error”.

**Example:**

```
→   PPP CNF 0 mobile.vodafone.it 0 user pass www.google.com  
←   PPP CNF EXECUTING
```



## 21.5. VPN ON

This command can be used to activate the VPN Box function; the function is activated with the system configuration parameters (Server, Password, Tag Name).

The command has two optional parameters, so its format is as follows:

```
VPN ON [PPP] [NOFWL]1
```

“PPP”

If this parameter is present, the mobile data connection (PPP) is configured (if not already active), before activating the VPN Box function

“NOFWL”

If this parameter is present, “Mobile Network Firewall” is disabled in the system configuration

This command is rejected in the following cases:

- if the “custom” VPN function is enabled in the system configuration (parameter “VPN/Enable” = ON, “VPN Mode” = “OpenVPN”), the command will not be executed, generating the “System VPN ON” error;
- if the “Remote Connection Disable” (RCD) digital input is HIGH and the “Security Level/Service Disable” parameter is set to VPN Connection”, “VPN Service” or “Internet Connection”, the command will fail and generate the “Security Level error”.

Please note that this command does not activate the VPN Box function permanently; therefore, if the device is rebooted, the function will not be reactivated.

Examples:

```
→ VPN ON
← VPN ON EXECUTING

→ VPN ON PPP
← VPN ON PPP EXECUTING

→ VPN ON NOFWL
← VPN ON NOFWL EXECUTING

→ VPN ON PPP NOFWL
← VPN ON PPP NOFWL EXECUTING
```

<sup>1</sup> Square brackets indicate that the parameter is optional.

## 21.6. VPN OFF

This command can be used to disable the VPN Box function activated with a previous “VPN ON” command; it also disables the mobile data connection (PPP) configured with a previous “VPN ON PPP” command or with the “PPP ON” command.

This command is never rejected.

Please note that this command does not disable the VPN Box function permanently; therefore, if the device is rebooted, the function will be re-enabled.

Example:

```
→ VPN OFF
← VPN OFF EXECUTING
```

## 21.7. VPN CNF

This command can be used to change the value of the system configuration parameters related to the VPN Box function; the changes are permanent.

The command will have the following format and the parameter values must be separated by a blank space:

```
VPN CNF <Server> <Password> <Tag Name>
```

All parameters must be present in the above order; no parameter can be left empty.

As for the meaning of these parameters.

This command is rejected in the following case:

If any of the command parameters is missing or invalid, the command will fail and generate the “Command parameter error”.

Example:

```
→ VPN CNF myvpnbox.seneca.it myvpnbox zpass2-GSP
← VPN CNF EXECUTING
```

## 21.8. FWL ON

This command can be used to enable “Mobile Network Firewall” in the system configuration (parameter “Mobile Network Firewall/Enable” = ON).

This command is never rejected.

Example:

```
→   FWL ON
←   FWL ON EXECUTING
```

## 21.9. FWL OFF

This command can be used to disable “Mobile Network Firewall” in the system configuration (parameter “Mobile Network Firewall/Enable” = OFF).

This command is never rejected.

Example:

```
→   FWL OFF
←   FWL OFF EXECUTING
```

## 21.10. GET DIN

This command can be used to get the status of one or all digital inputs of the device; if a digital input is not available (because it is used as an output)<sup>2</sup>, the value “0” is returned.

The command can have two formats:

GET DIN<n>                      with <n>=1..N                      gets the status of a single digital input

where:

N=4 per R-PASS+R-COMM

N=6 per Z-PASS2-RT-4G

GET DIN    gets the status of all digital inputs

This command is rejected in the following cases:

- if the digital I/O number is out of range (for example: 0 or N+1), the command will not be executed and generate the “Command parameter error”.

Examples:

```
→   GET DIN
←   GET DIN EXECUTING (1,0,0,0)

→   GET DIN1
←   GET DIN1 EXECUTING (1)
```

<sup>2</sup> This condition can be true for Z-PASS2-RT-4G.

```
→ GET DIN2
← GET DIN2 EXECUTING (0)
```

### 21.11. GET DOUT

This command can be used to get the state of one or all of the device's digital outputs; if a digital output is not available (because it is used as an input)<sup>3</sup>, the value "0" is provided.

The command can have two formats:

GET DOUT<n>                      con <n>=1..N                      gets the status of a single digital output

where:

N=4 per R-PASS+R-COMM

N=6 per Z-PASS2-RT-4G

GET DOUT    gets the status of all digital outputs

This command is rejected in the following cases:

- if the digital I/O number in the command is out of range (for example: 0 or N+1), the command will not be executed and generate the "Command parameter error".

Examples:

```
→ GET DOUT
← GET DOUT EXECUTING (0,1,0,0)

→ GET DOUT1
← GET DOUT1 EXECUTING (0)

→ GET DOUT2
← GET DOUT2 EXECUTING (1)
```

### 21.12. SET DOUT

This command can be used to set the state of one of the device's digital outputs.

The command can have two formats:

SET DOUT<n>.CLOSE              with <n>=1..N              sets the digital output to HIGH status

SET DOUT<n>.OPEN                      with <n>=1..N              sets the digital output to LOW status

where:

N=4 per R-PASS+R-COMM

N=6 per Z-PASS2-RT-4G

<sup>3</sup> This condition can be true for Z-PASS2-RT-4G.

This command is rejected in the following cases:

- if the digital output is not configured as “General output” or the digital I/O is used as input<sup>4</sup>, the command will not be executed generating the “Digital I/O mode error”;
- if the digital I/O number in the command is out of range (for example: 0 or N+1), the command will not be executed, generating the “Command parameter error”;
- if the requested state is neither “.CLOSE” nor “.OPEN”, the command will not be executed, generating the “Command parameter error”.

Example:

```
→ SET DOUT2.CLOSE
← SET DOUT2.CLOSE EXECUTING
```

### 21.13. SET PULSE

This command can be used to generate a pulse on one of the device's digital outputs.

The command can have two formats:

```
SET PULSE<n>.CLOSE <duration> with <n>=1..N
```

where:

N=4 per R-PASS+R-COMM

N=6 per Z-PASS2-RT-4G

to generate a LOW-HIGH-LOW pulse, with the HIGH state set for the number of seconds specified by the <duration> parameter

```
SET PULSE<n>.OPEN <duration> with <n>=1..N
```

where:

N=4 per R-PASS+R-COMM

N=6 per Z-PASS2-RT-4G

to generate a LOW-HIGH-LOW pulse, with the LOW state set for the number of seconds specified by the <duration> parameter

This command is rejected in the following cases:

- if the digital output is not configured as “General output” or the digital I/O is used as input<sup>5</sup>, the command will not be executed generating the “Digital I/O mode error”;
- if the digital I/O number in the command is out of range (for example: 0 or N+1), the command will not be executed, generating the “Command parameter error”;
- if the requested state is neither “.CLOSE” nor “.OPEN”, the command will not be executed, generating the “Command parameter error”;
- if the <duration> parameter is missing or invalid, the command will not be executed, generating the “Command parameter error”;

<sup>4</sup> This condition can be true for Z-PASS2-RT-4G.

<sup>5</sup> This condition can be true for Z-PASS2-RT-4G.

- if the “.CLOSE” parameter is specified and the digital output is already in the HIGH state, the command will not be executed, generating the “No pulse generated” error;
- if the “.OPEN” parameter is specified and the digital output is already in the LOW state, the command will not be executed, generating the “No pulse generated” error.

Example:

```
→ SET PULSE2.CLOSE 10
← SET PULSE2.CLOSE 10 EXECUTING
```

## 21.14. SET USER.PHONE

This command can be used to insert a user with specified phone number, type and group list into the Address Book; it can also be used to modify the type and/or group list of an existing user.

The command has the following format:

```
SET USER.PHONE +<number> <type> <group list>, with <type>=ADM|MGR|USR
```

Please note that the phone number must always be indicated with “international format”, therefore the initial character ‘+’ must always be present.

“group list” is a list of non-negative integers, separated by the character “-”, that defines the groups to which the user belongs. An example of valid group lists is the following:

```
“1-2-3”
“1-4”
“1”
“0”
```

The value “0” indicates that the user does not belong to any group.

This command is rejected in the following cases:

- if the <number> parameter already exists in the Address Book, with <type> and <group list> specified, the command will fail, generating the “Item already exists” error;
- if the <number> parameter is missing or invalid (including the case where the ‘+’ character is missing), the command will fail, generating the “Command parameter error”;
- if the <type> parameter is missing or invalid, the command will fail, generating the “Command parameter error”;
- if the <group list> parameter is missing or invalid, the command will fail, generating the “Command parameter error”.

Example:

```
→ SET USER.PHONE +390123456789 ADM 1-2-3
← SET USER.PHONE +390123456789 ADM 1-2-3 EXECUTING
```

### 21.15. RESET PHONE

This command can be used to delete a user with the specified phone number from the Address Book.

The command has the following format:

```
RESET PHONE +<number>
```

Please note that the phone number must always be indicated with “international format”, therefore the initial character ‘+’ must always be present.

This command is rejected in the following cases:

- if the specified <number> parameter does not exist in the Address Book, the command will fail with the “Item does not exist” error;
- if the <number> parameter is missing or invalid (including the case where the ‘+’ character is missing), the command will fail with the “Command parameter error”.

Example:

```
→ RESET PHONE +390123456789  
← RESET PHONE +390123456789 EXECUTING
```

Please note that if the user in the Address Book with the specified phone number also has an email address, this command will also delete it.

### 21.16. SET USER.EMAIL

This command can be used to insert a user with specified email address, type and group list into the Address Book; it can also be used to change the type and/or group list of an existing user.

The command has the following format:

```
SET USER.EMAIL <email address> <type> <group list>, with  
<type>=ADM|MGR|USR
```

“group list” is a list of non-negative integers, separated by the character “-”, that defines the groups to which the user belongs. An example of valid group lists is the following:

“1-2-3”

“1-4”

“1”

“0”

The value “0” indicates that the user does not belong to any group.

This command is rejected in the following cases:

- if the <email address> parameter already exists in the Address Book, with <type> and <group list> specified, the command will not be executed, generating the “Item already exists” error;

- if the <email address> parameter is missing or invalid, the command will not be executed, generating the “Command parameter error”;
- if the <type> parameter is missing or invalid, the command will fail, generating the “Command parameter error”;
- if the <group list> parameter is missing or invalid, the command will fail, generating the “Command parameter error”.

Example:

```
→ SET USER.EMAIL admin@zpass.it ADM 1-2-3
← SET USER.EMAIL admin@zpass.it ADM 1-2-3 EXECUTING
```

### 21.17. RESET EMAIL

This command can be used to delete a user with a specified email address from the Address Book.

The command has the following format:

```
RESET EMAIL <email address>
```

This command is rejected in the following cases:

- if the specified <email address> parameter does not exist in the Address Book, the command will not be executed, generating the “Item does not exist” error;
- if the <email address> parameter is missing or invalid, the command will not be executed, generating the “Command parameter error”.

Example:

```
→ RESET EMAIL admin@zpass.it
← RESET EMAIL admin@zpass.it EXECUTING
```

Please note that if the user in the Address Book with the specified email address also has a phone number, this number will also be deleted using this command.

### 21.18. STATUS

This command can be used to get status information from the device.

The status information provided in the response has the following format:

R-PASS+R-COMM:

```
R-PASS<hwrev> <date> <time> RUNNING <service status>,<vpn status>
<DI1>,<DI2>,<DI3>,<DI4>,<DO1>,<DO2>,<DO3>,<DO4>
```

Z-PASS2-RT-4G:

```
Z-PASS2-RT-4G<hwrev> <date> <time> RUNNING <service status>,<vpn status> <DIDO1>,<DIDO
2>,<DIDO3>,<DIDO4>,<DIDO5>,<DIDO6>
```

where:



<hwrev>: ""

<date> is in the format "yyyy/mm/dd"

<hour> is in the format "hh:mm:ss"

<service status> indicates the state of "SRV" LED<sup>6</sup> ("OFF"|"ON"|"FAIL")

<vpn status> reports the status of the "VPN" LED ("OFF"|"ON"|"FAIL")

<DI1>,<DI2>,..., <DIDO5>,<DIDO6>, status ("LO"|"HI") of the digital I/Os

This command is never rejected.

Example:

```
→ STATUS
← STATUS EXECUTING (Z-PASS2-RT-4G 2018/03/09 08:01:31 RUNNING
OFF, OFF HI, LO, HI, LO, LO, LO)
```

### 21.19. GET GPS

This command can be used to get GPS location information from the device.

The response is provided as a URL on Google Maps™:

<https://www.google.com/maps/?q=<latitude>,<longitude>>

This command is rejected in the following cases:

- if the GPS signal is not available, the command will not be executed generating the "GPS not fixed" error.

Example:

```
→ GET GPS
← GET GPS EXECUTING
(https://www.google.com/maps/?q=45.3742,11.94557)
```

### 21.20. RESET

This command can be used to reboot the device.

This command is never rejected.

Example:

```
→ RESET
← RESET EXECUTING
```

### 21.21. GET TAG

<sup>6</sup> See the "Signal LED" Chapter.

This command can be used to get the value of a tag (see the “Modbus Shared Memory Gateway” feature).  
The command has the following format:

```
GET TAG <tag name>
```

Note that “tag name” is case-sensitive; also, this command assumes that each tag has a distinct name; if there are multiple tags with the same name, this command returns the value of the first tag encountered with the specified name.

The value is shown in the response with the following format:

```
<tag value>,VALID
```

or:

```
<tag value>,INVALID
```

The “INVALID” status may occur for tags with “GATEWAY MODE”=“GATEWAY”, when the last Modbus read request failed.

This command is rejected in the following cases:

- if no serial port has “Gateway Mode”=“Modbus Shared Memory”, the command will not be executed generating the error “Modbus Gateway not active”;
- if no tags with the specified name are found, the command will not be executed generating the “Tag does not exist” error;
- if the requested tag has “GATEWAY MODE”=“BRIDGE” and the Modbus read request fails, the command will not be executed generating the “Tag operation failed” error.

Example:

```
→ GET TAG GPS_LONGITUDE
```

```
← GET TAG GPS_LONGITUDE EXECUTING (11.94528,VALID)
```

## 21.22. SET TAG

This command can be used to set the value of a tag (see the “Modbus Shared Memory Gateway” feature).  
The command has the following format:

```
SET TAG <tag name> <tag value>
```

Note that “tag name” is case-sensitive; also, this command assumes that each tag has a distinct name; if there are multiple tags with the same name, this command attempts to set the value of the first tag encountered with the specified name.

For non-integer tag values, the decimal point character ‘.’ will be used.

This command is rejected in the following cases:

- if no serial port has “Gateway Mode”=“Modbus Shared Memory”, the command will not be executed generating the error “Modbus Gateway not active”;

- if no tags with the specified name are found, the command will not be executed generating the “Tag does not exist” error;
- if the specified value does not match the “Data Type” of the target tag (for example, the value “2” for a “BOOLEAN” tag), the command will fail with an “Invalid value for tag” error;
- if, for any reason, the write operation fails, the command will fail with a “Tag operation failed” error; this includes the following cases:
  - o Modbus write request fails for “GATEWAY” or “BRIDGE” tags;
  - o the tag value cannot be changed because it is not a “General output” tag, for digital I/O tags (“EMBEDDED”);
  - o the tag value cannot be changed because it is a “GPS info” tag (“EMBEDDED”).

Example:

```
→ SET TAG ZPASS_DO 10
← SET TAG ZPASS_DO 10 EXECUTING
```

### 21.23. OVPN ON

This command can be used to activate the standard OPEN VPN function; the function is activated with the system configuration parameters (Server, Password, Tag Name).

Please note that this command does not activate the OPEN VPN function permanently; therefore, if the device is rebooted, the function is not reactivated.

Examples:

```
→ OVPN ON
← OVPN ON EXECUTING
```

### 21.24. OVPN OFF

This command can be used to disable the OPEN VPN feature activated with a previous “OVPN ON” command.

Please note that this command does not disable the OPEN VPN feature permanently; therefore, if Z-PASS is restarted, the feature will be re-enabled.

Example:

```
→ OVPN OFF
← OVPN OFF EXECUTING
```

### 21.25. CLEAN LOGS

This command will delete all data logs.

```
→ CLEAN LOGS
```

← CLEAN LOGS EXECUTING

## 22. DEVICE FIRMWARE UPDATE

The firmware can be updated from the web page (FW UPDATE section) or with a USB stick formatted with the FAT32 file system.

### 22.1. FIRMWARE UPDATE FROM USB STICK

For updating fw from USB port, the procedure is as follows:

Download the FW file from the Seneca website

the downloaded file is a .zip file; extract the .bin file; the FW file must be of the following type:

*SW00xxxx\_xxx.bin*

- 1) Copy this file to the root of the USB pen
- 2) Turn off the device
- 3) Insert the USB pen into the USB port
- 4) Turn on the device

The update procedure will take a few minutes to complete; during this time, the device **MUST NOT** be turned off.

## 23. FACTORY RESET

With this procedure it is possible to obtain

- 1) All the parameters at the factory
- 2) All folders are cleared (and therefore all data log files and debugging files are deleted).

### 23.1. FACTORY RESET FOR SSD

To obtain a factory reset follow the following procedure:

- 1) Turn off the device
- 2) Reach the back of the device and locate the dip switches as shown in the picture:

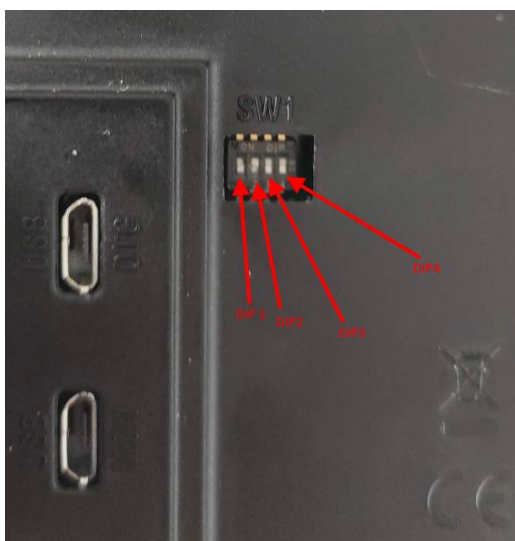

- 3) Bring the dip switches in: DIP1 = OFF, DIP2 = ON, DIP3 = ON, DIP4 = ON
- 4) Switch the device on and wait until it has completed charging
- 5) With the device switched on, bring the dips in: DIP1 = OFF, DIP2 = ON, DIP3 = OFF, DIP4 = OFF

### 23.2. FACTORY RESET FOR R-PASS AND R-PASS-S

To obtain a factory reset follow the following procedure:

- 1) Turn off the device
- 2) Reach the back of the device and locate the dip switches as shown in the picture:

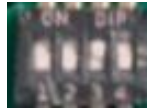

- 3) Bring the dip switches in: DIP1 = OFF, DIP2 = ON, DIP3 = ON, DIP4 = ON
- 4) Switch the device on and wait until it has completed charging
- 5) With the device switched on, bring the dips in: DIP1 = OFF, DIP2 = ON, DIP3 = OFF, DIP4 = OFF

### 23.3. FACTORY RESET FOR Z-PASS1-RT, Z-PASS2-RT, Z-TWS4-RT-S, Z-PASS2-RT-S

To obtain a factory reset follow the following procedure:

- 1) Turn off the device
- 2) Reach the back of the device by removing the cover on the bottom of the device and locate the DIP SW1 set
- 3) Bring the dip switches in: DIP1 = ON, DIP2 = ON, DIP3 = ON, DIP4 = OFF, DIP5=ON, DIP6 =ON
- 4) Switch the device on and wait until it has completed charging
- 5) Bring the dips to: DIP1 = ON, DIP2 = ON, DIP3 = ON, DIP4 = OFF, DIP5=OFF, DIP6 =OFF

## 24. MODBUS ADDRESSES OF EMBEDDED I/OS OF DEVICES

The embedded I/Os of the devices can also be accessed externally via the Modbus TCP-IP or RTU protocol through the addresses listed here:

### 24.1. MODBUS ADDRESSES OF SSD I/Os

<i>Data Type</i>	<i>Digital I/Os</i>	<i>Default address offset</i>
Holding Registers	Bit 0: DI1 (LSB) Bit 1: DI2	0 (40001)
Holding Registers	Bit 0: DO1 (LSB) Bit 1: DO2	1 (40002)
Holding Registers	Bit 0: Maintenance Mode	2 (40003)
Holding Registers	Analog Input 1 (UINT16)	3 (40004)
Holding Registers	Analog Input 2 (UINT16)	4 (40005)

Holding Registers	Internet Access (0 = None, 1 = ETH, 2 = WIFI)	50 (40051)
Discrete Inputs	DI1	0 (10001)
Discrete Inputs	DI2	1 (10002)
Coils	DO1	0
Coils	DO2	1

24.2. MODBUS ADDRESSES OF R-PASS I/Os

<b>Data Type</b>	<b>Digital I/Os</b>	<b>Indirizzo di default</b>
Holding Registers	Bit 0: DI1 (LSB) Bit 1: DI2 Bit 2: DI3 Bit 3: DI4	0 (40001)
Holding Registers	Bit 0: DO1 (LSB) Bit 1: DO2 Bit 2: DO3 Bit 3: DO4	1 (40002)
Holding Registers	Bit 0: Maintenance Mode	2 (40003)
Holding Registers	Internet Access (0 = None, 1 = ETH, 2 = WIFI, 3 = Mobile)	50 (40051)
Discrete Inputs	DI1	0 (10001)
Discrete Inputs	DI2	1 (10002)
Discrete Inputs	DI3	2 (10003)
Discrete Inputs	DI4	3 (10004)
Coils	DO1	0
Coils	DO2	1
Coils	DO3	2
Coils	DO4	3
Holding Registers	Analog Input 1 (UINT16)	3 (40004)
Holding Registers	Analog Input 2 (UINT16)	4 (40005)

24.3. MODBUS ADDRESSES OF Z-PASS1-RT, Z-PASS2-RT I/Os

<b>Data Type</b>	<b>Digital I/Os</b>	<b>Indirizzo di default</b>
Holding Registers	Bit 0: DI1 (LSB) Bit 1: DI2 Bit 2: DI3 Bit 3: DI4 Bit 4: DI5 Bit 5: DI6	0 (40001)

Holding Registers	Bit 0: DO1 (LSB) Bit 1: DO2 Bit 2: DO3 Bit 3: DO4 Bit 4: DO5 Bit 5: DO6	1 (40002)
Holding Registers	Bit 0: Maintenance Mode	2 (40003)
Holding Registers	Analog Input 1 (UINT16)	3 (40004)
Holding Registers	Analog Input 2 (UINT16)	4 (40005)
Holding Registers	Internet Access (0 = None, 1 = ETH, 2 = WIFI, 3 = Mobile)	50 (40051)
Discrete Inputs	DI1	0 (10001)
Discrete Inputs	DI2	1 (10002)
Discrete Inputs	DI3	2 (10003)
Discrete Inputs	DI4	3 (10004)
Discrete Inputs	DI5	4 (10005)
Discrete Inputs	DI6	5 (10006)
Coils	DO1	0
Coils	DO2	1
Coils	DO3	2
Coils	DO4	3
Coils	DO5	4
Coils	DO6	5

## 25. “UA EXPERT” CLIENT CONFIGURATION

This chapter will provide the steps to configure the connection and the correct security policy with the “UA Expert” client software

Click Server-> Add

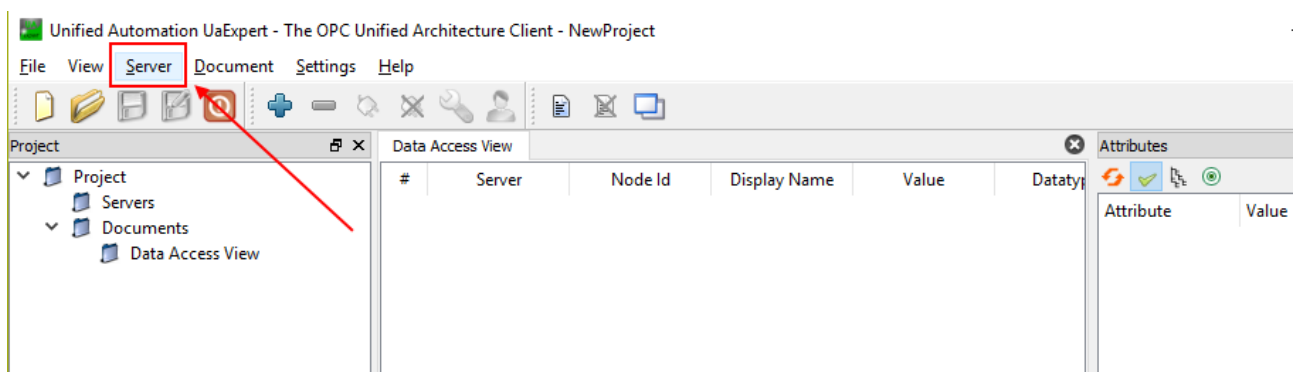



In "Custom Discovery" enter the url for the OPC-UA server:

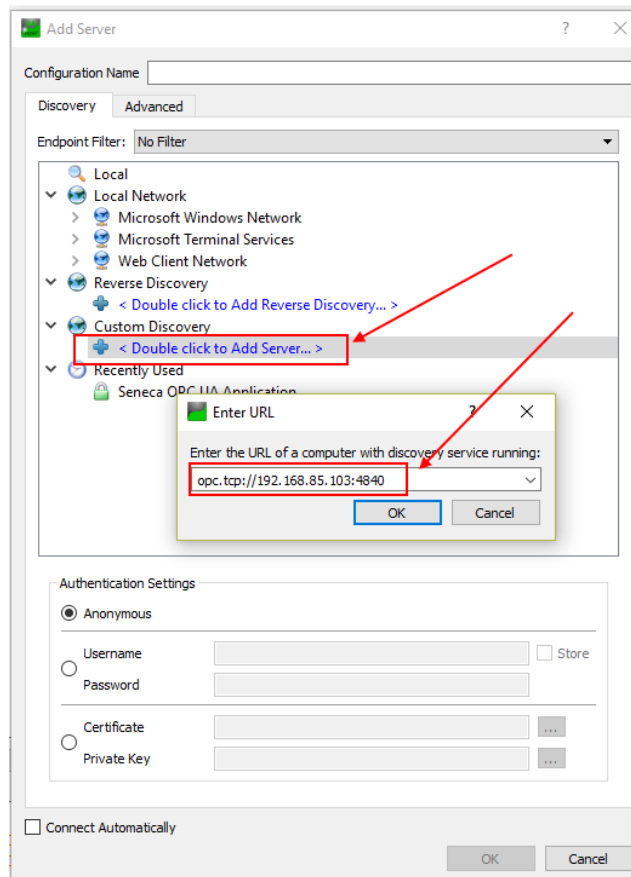

Press OK.

Supported security policies are now displayed:

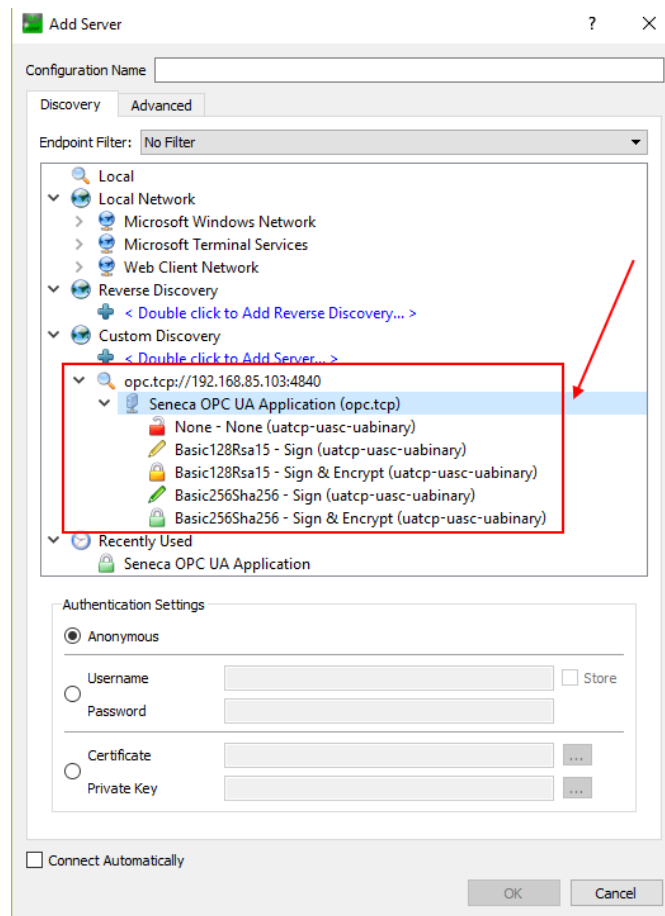

Select the one to use.

Then go to Authentication settings and enter the user name and password configured in the OPC-UA server:

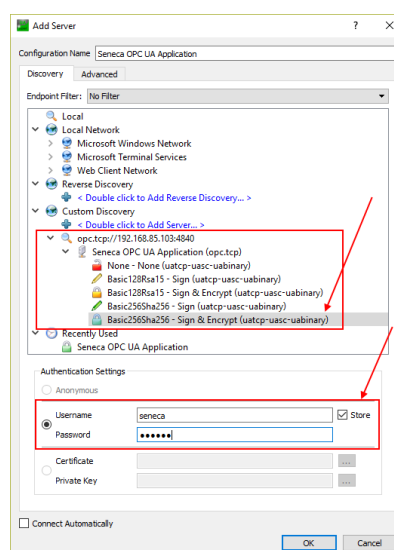

Press OK:

Now it is possible to connect to the server using the appropriate icon:

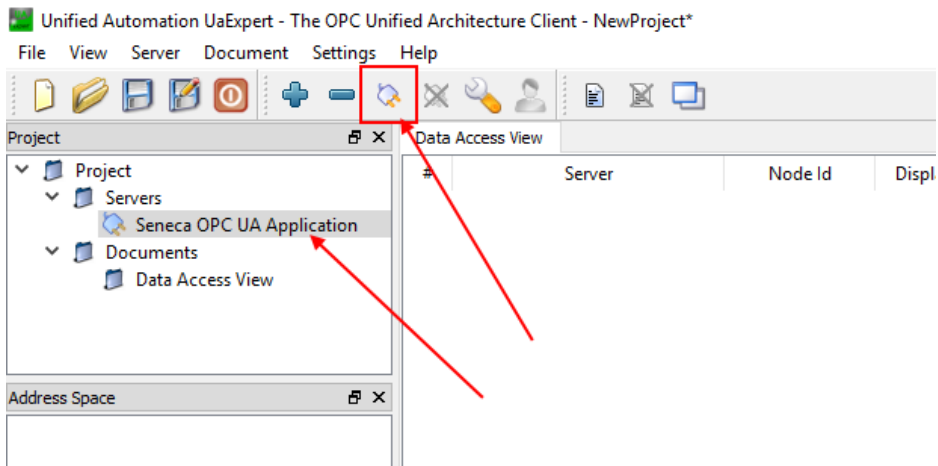

A new server certificate validation dialog will open. After reviewing the certificate, select Trust Server Certificate to permanently add the certificate to UaExpert's trust list. It is also possible to check the appropriate box to temporarily accept the server certificate for this session and choose Continue to not save the certificate to the trusted list or select Cancel to reject the certificate.

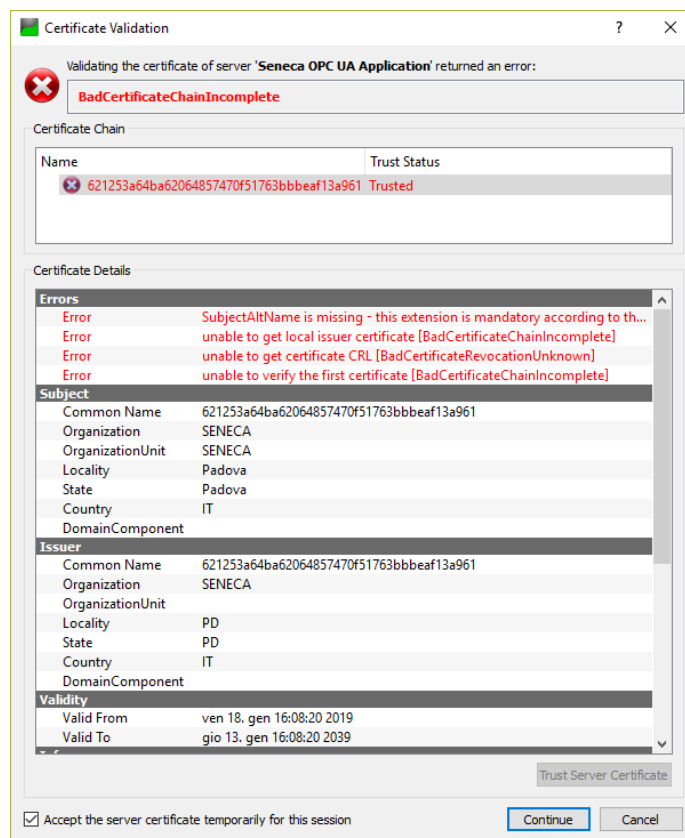

The Certificate Error window will now appear:

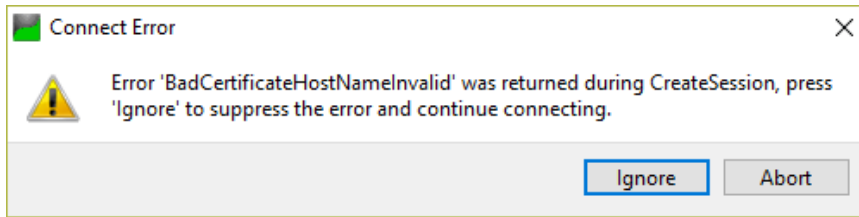

Click on "Ignore" to continue.

Now the connection is established, you can read/write the value of the tags

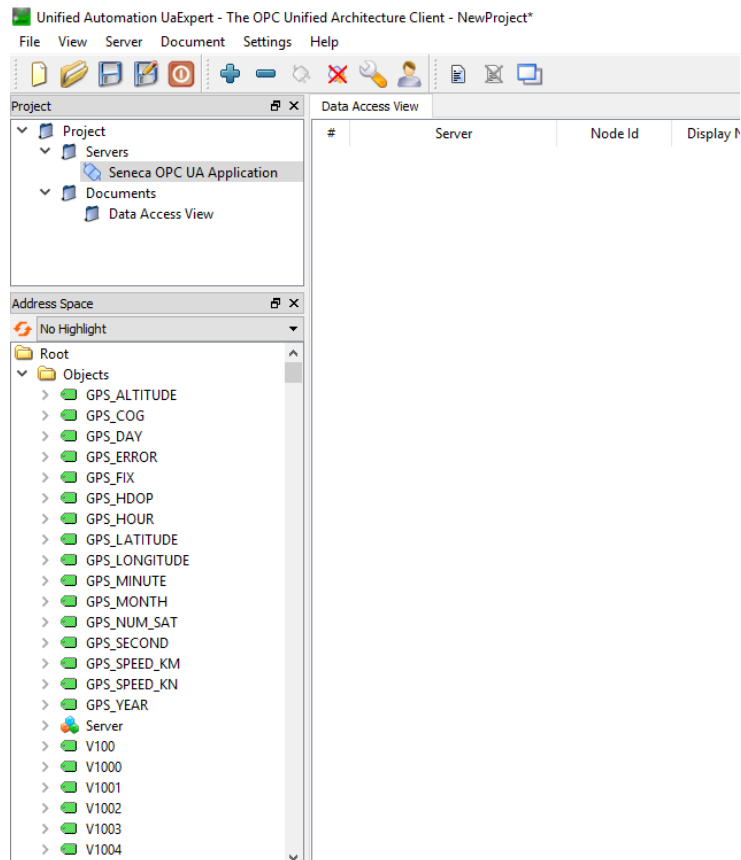

To update the tags in real time, drag and drop what you want to display:

Unified Automation UaExpert - The OPC Unified Architecture Client - NewProject\*

File View Server Document Settings Help

Project: # X

Data Access View

#	Server	Node Id	Display Name	Value	Datatype	Source Timestamp	Server Timestamp	Statuscode
1	Seneca OPC UA Application	NS1 String V1004	V1004	0	UInt16	15:23:13.097	15:23:13.097	Good
2	Seneca OPC UA Application	NS1 String V1025	V1025	0	UInt16	15:23:25.556	15:23:25.556	Good
3	Seneca OPC UA Application	NS1 String V1026	V1026	0	UInt16	15:23:25.556	15:23:25.556	Good

Address Space: # X

No Highlight

- > V1012
- > V1013
- > V1014
- > V1015
- > V1016
- > V1017
- > V1018
- > V1019
- > V102
- > V1020
- > V1021
- > V1022
- > V1023
- > V1024
- > V1025
- > V1026
- > V1027
- > V1028
- > V1029
- > V103
- > V1030
- > V1031
- > V1032
- > V1033
- > V1034